



IMfinity® FFB brake motors

Standard Efficiency Not Concerned by IE Standards and IE3 High Efficiency

Variable speed and Fixed speed

Frame size from 71 to 180
Power from 0.25 to 18.5 kW

LERROY-SOMER™

Nidec
All for dreams

Brake ranges

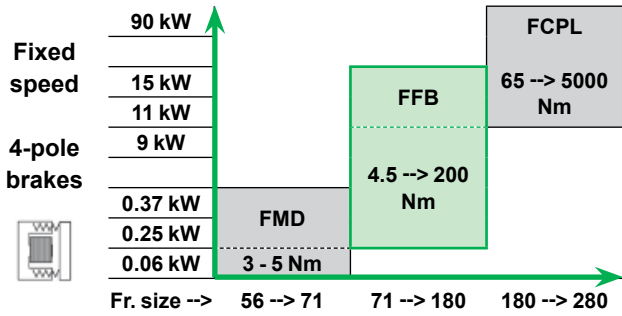

Associated documentations

		Environment		Dust-protected II3D
		Normal	Commissioning	
FFB brochure	FFB catalog	FFB installation	FFB maintenance	
5846	5329	5286	5287	



All brake motors in this catalogue that don't fall within the scope of regulation 640/2009 in directive 2009/125/CE they can be offered for sale* on the European Union market.

* according to the definition relating to application of European Union regulations concerning products.

FFB brake motors offer

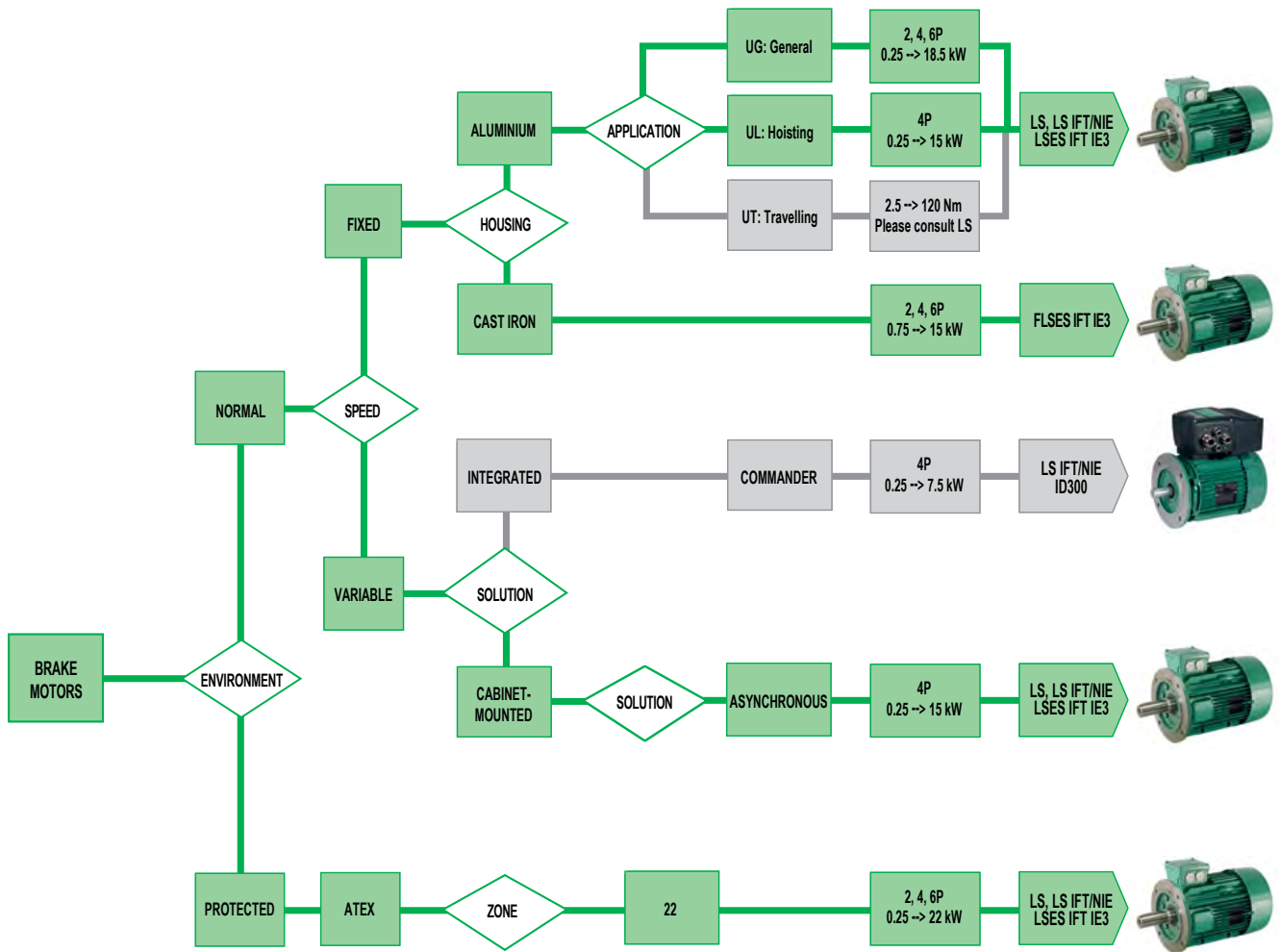

Associated Gearbox ranges

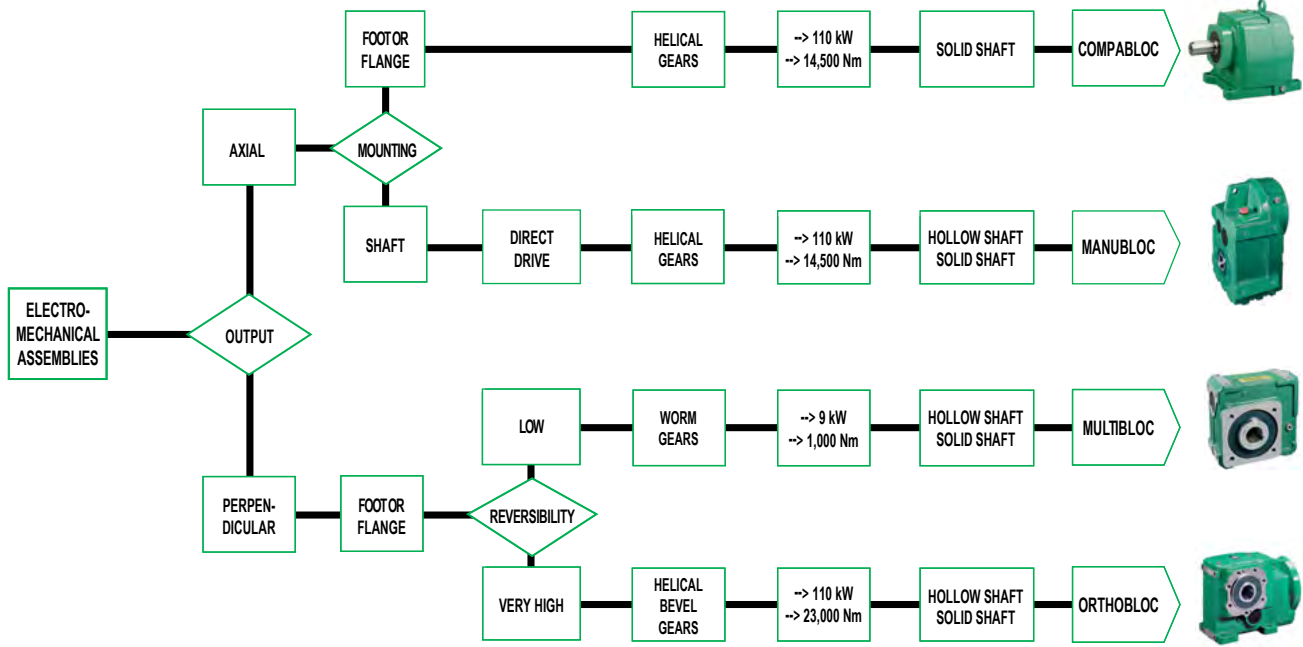

Associated Drives ranges

Variable speed	LS IFT/NIE, LSES IFT/IE3, FLSES IFT/IE3			LS IFT/NIE	
	110 kW	75 kW -->	45 kW -->	7.5 kW	4 kW
110 kW	DIGISTART				
75 kW -->					
45 kW -->					
--> 22 kW					
--> 11 kW					
7.5 kW					
2.2 kW -->					
1.1 kW					
0.37 kW					
0.25 kW					
	Starter	Cabinet-mounted variable speed		Built-in variable speed	
		UNIDRIVE M	POWERDRIVE	ID300	ID300
		M700	MD2M	400V T	230V T
		M400	FX	230V M	COMMANDER ID300
		M600	F300		
		M300			
		M200			



Contents

INTRODUCTION	
Offer, range.....	2-3
Index.....	5
Glossary	6
CONSTRUCTION	
Mounting forms and operating positions.....	7
OPERATION	
DEFINITION OF BRAKE MOTOR	
Areas of use	8
Failsafe brake	8
Using the brake motor at constant torque (0 to 87 Hz).....	8
DUTY CYCLE DEFINITIONS	
Duty cycles	9
S4 Operating rates	10
No-Load starting frequency	10
Brake energy capacity	10
ELECTROMAGNET CHARACTERISTICS	11
BRAKE POWER SUPPLY UNIT CHARACTERISTICS	11
Operating principle	11
Definition of built-in or separate power supply.....	11
BRAKING TORQUES	12
MOMENT OF INERTIA	13
RESPONSE TIME WITH BRAKE ONLY AND STOPPING DISTANCE	
Definition of response times	13
Response time values	14
Noise level.....	14
Stopping time and distance calculations	14
Brake wear calculation	14
LOADS APPLIED TO THE MOTOR (MAIN) SHAFT.....	15
EXAMPLE OF SELECTION.....	15
IP55 ALUMINIUM FRAME	
DESIGNATION.....	16
LS(ES) FFB DESCRIPTION	17
CHARACTERISTICS TABLES	
LS FFB IFT/NIE - 4-pole.....	18
LS FFB IFT/NIE - 2-pole.....	20
LS FFB IFT/NIE - 6-pole.....	21
LSES FFB IFT/IE3 - 4-pole.....	22-23
LSES FFB IFT/IE3 - 2-, 6-pole	24
LS(ES) FFB DIMENSIONS	
Foot mounted IM 1001 (IM B3).....	25
Flange mounted IM 3001 (IM B5).....	26
Face mounted IM 3601 (IM B14).....	27
IP55 CAST IRON FRAME	
DESIGNATION.....	28
FLSES FFB DESCRIPTION	29
CHARACTERISTICS TABLES	
FLSES FFB IFT/IE3 - 4-pole	30-31
FLSES FFB IFT/IE3 - 2-, 6-pole	32
FLSES FFB DIMENSIONS	
Foot mounted IM 1001 (IM B3).....	33
Flange mounted IM 3001 (IM B5).....	34
Face mounted IM 3601 (IM B14).....	35
EQUIPMENT AND OPTIONS	
LIST AND COMPATIBILITY OF OPTIONS	36
MECHANICAL OPTIONS	
Optional flanges for LS(ES) FFB, FLSES FFB series	37
Release systems	38-39
Non Drive End shaft	39
Optional braking torque	40
Indicator lamp (release/application, wear).....	40
Drip cover	40
ELECTRICAL OPTIONS	
Sensors	41
Cable gland	42
Forced axial ventilation	42
Choice of speed and position feedback	43
Encoders characteristics	43
Encoders dimensions	42-43
Encoders connection	44
IDENTIFICATION - INSTALLATION	
IDENTIFICATION	
Motor nameplate.....	45
Brake nameplate	45
EXPLODED VIEWS AND PARTS LIST.....	46-47
INSTALLATION	
Receipt	48
Storage	48
Commissioning.....	48
Mechanical installation	48
Wiring	48-49
PACKAGING WEIGHTS AND DIMENSIONS.....	50
APPENDIX	
Configurator.....	51
Express Availability.....	51

Index

Air gap	12, 13	Inertia.....	16, 18-24, 30-32
Ambient temperature	12	Ingress protection	17, 39, 45
Application	16, 28	Installation	48, 49
Application/release indicator.....	36, 40		
Approvals.....	45	Lining.....	12
ATEX	2, 45	Load on the shaft	14
Axial force	15	LS(ES) FFB UG/UL.....	16-27
Booster	13, 14	Maintenance	2
Brake motor at constant torque	8	Manual release	14, 38, 40
Brake power supply	11	Mb: Multibloc.....	2
Brake release.....	14, 38, 40	Moment of inertia	13, 18-24, 30-32
Brakes	2, 8-49	Mounting.....	7, 25-27, 33-35
Braking torque	12, 18-24, 30-32, 40	Mub: Manubloc	2
Cable gland	7, 17, 29, 42	Nameplates	45
Cb: Compabloc.....	2	Noise	14
CE.....	45	No-load starting frequency.....	10
Characteristics.....	11, 18-24, 30-32	Non Drive End shaft.....	39
Choice of speed feedback.....	43	Number of braking operations	12
Commander ID300	3		
Components	17, 29, 46, 47	Operating positions	7
Configurator.....	51	Options	36-44
Connection diagrams.....	11, 13, 49	Ot: Orthobloc	2
Crankshaft socket.....	39		
CSA	45	Packaging	50
		Parts list.....	46, 47
Definition of symbols	7, 45	Possible flanges.....	26, 27, 34, 35, 37
Description.....	17, 29		
Designation.....	16, 28	Reduced brake response time	14
Dimensions of options.....	37-44	Release lever.....	38, 39
Dimensions.....	25-27, 33-35	Release systems	38, 39
Direction of rotation.....	17, 29	Running-in	13
Drain holes.....	17, 29, 36		
Drip cover	36, 40	Safety	8
Drive power supply	18, 19-22, 23-30, 31	Selection data	18-24, 30-32
Drives	2	Selection tables	18-24, 30-32
Duty cycles	9, 10	Sensors	36, 41
		Shaft on Non Drive End.....	39
Electromagnet	11	Starting	10
Encoders	43, 44	Storage.....	48
Environment	12		
Equipment	36-44	Terminal box	17, 25 to 27, 29, 33 to 35, 42
Example of selection.....	15		
Exploded views.....	46, 47	UG general applications	8, 16, 17, 28, 29
Express Availability	51	UL hoisting applications	8, 11, 16, 17, 28, 29
External finish	17, 29		
		Variable speed	8, 18-24, 30-32, 49
Flange form	7, 26, 27, 34, 35, 37		
FLSES FFB UG/UL.....	28-35	Wear indicator	36, 40
Foot form	7, 25, 33	Wear	12
Forced ventilation	36, 38, 42, 43		
Ground terminal	17, 29		
Grounding.....	12		
Help in defining your order	15		
Holding the load.....	8		
Humidity.....	12		
ID300/302	3		
Identification	45		

Glossary

BA	Shaft extension	M_R	Resistive torque
Cb	Compabloc	Mub	Manubloc
Cos φ	Power factor	m	Weight
E	Energy	n	Number of starts
FLSES	Cast iron motor series	NIE	Not in any efficiency class
OF	Operating factor (%)	N_n	Rated speed
F_d	Starting frequency	ω_N	Angular speed of the motor
FJ	Inertia factor	Ot	Orthobloc
η	Efficiency	P_n	Rated power
R.H.	Relative humidity	P_u	Output power
Fr. S	Frame size	T	Cycle time
I_d	Starting current	T.A.	Ambient temperature
I_n	Rated current	t	Travel time
J	Moment of inertia	t_1	Release response time
J_c	Moment of inertia of the driven load	t_2	Application response time
J_m	Moment of inertia of the brake motor	t_{2DC}	Application response time with DC switch-off
kg	Weight (brake motor)	t_c	Total cycle time
KVA_n	Apparent rated power	t_f	Braking time
kW	Kilowatt	t_m	Motor running time in the cycle
LS(ES)	Aluminium motor series	U.G.	General applications
M_a	Pull-up torque	U.L.	Hoisting applications
Mb	Multibloc	v	Linear speed (m/s)
M_d	Starting torque	Z_c	Cycle starting frequency
M_f	Braking torque	Z_o	Brake motor starting frequency
M_m	Maximum torque	Z_{oc}	Cycle equivalent starting frequency
M_n	Rated torque		

Construction Mounting forms and operating positions

Foot mounted

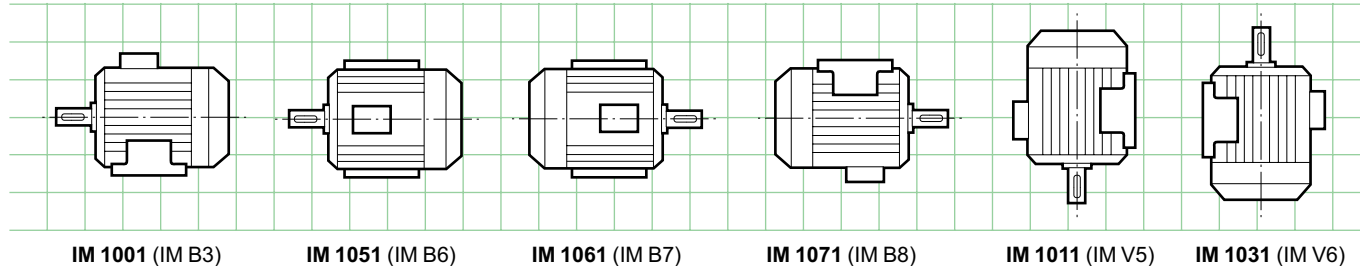

Flange mounted (FF)

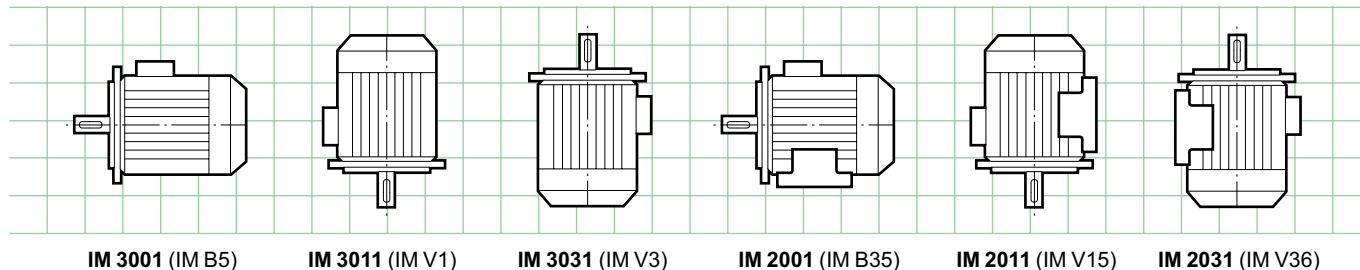

Face mounted (FT)

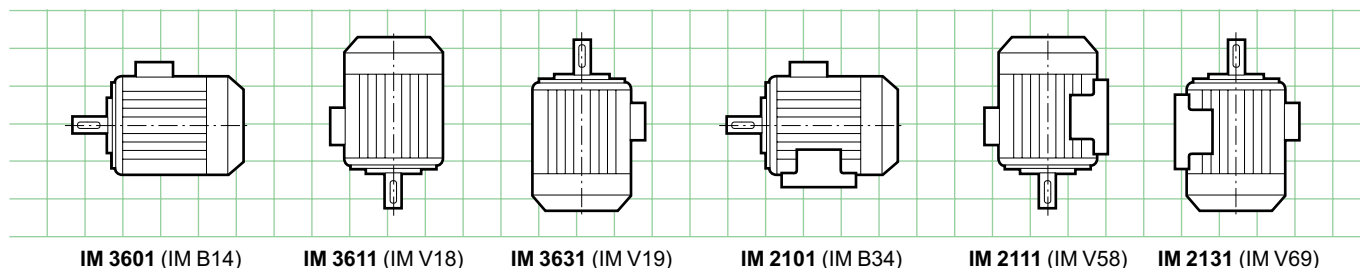

Terminal box positions

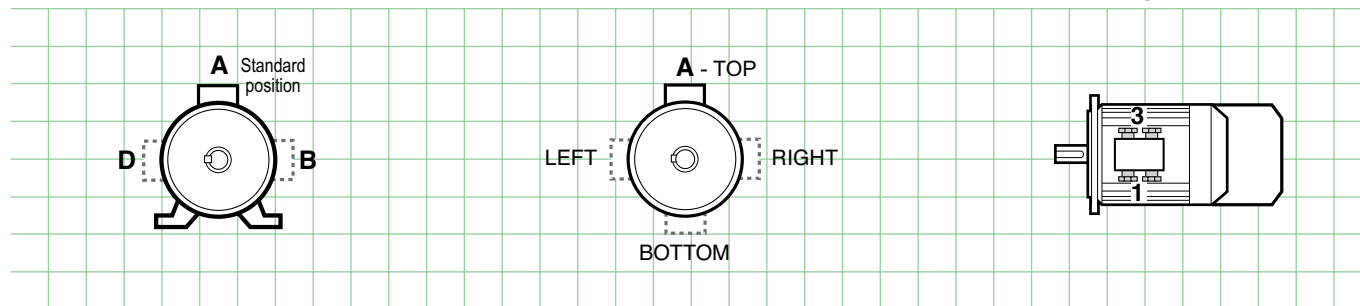

Optional cable gland positions

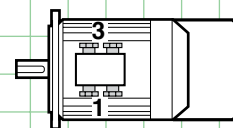

1 - Right
3 - Left

Operation Definition of the brake motor

The brake motor combines, in a single electromechanical assembly

- a motor: rotor + stator which forms the drive mechanism
- a control device: electromagnet + springs which apply or release the brake,
- friction: lining + mating surface which provide the braking action.

AERAS OF USE

• Intermittent duty: a mechanical device driven by a motor on its own takes a long time to stop if there is little friction. The brake motor ensures **shorter, accurate and safe stopping times**. It is used in handling where accuracy on stopping is required, and on production lines where the basic operations should be as done as quickly as possible.

• Emergency stops: on dangerous machinery such as presses, machine-tools, woodworking machines, the brake motor brings the machinery to a stop almost instantly and ensures **the operator's safety**. The brake motor can also improve product quality and the machine usage rate.

Indeed, on machines operating at continuous flow (printing or production line), **stopping quickly when a defect or fault** appears limits the effects and reduces the time taken to get started again.

• Holding a device under load: the brake motor can be used to hold the motor in standstill position, even if torque is still applied. Since the motor is powered off in UL hoisting applications (hoists, elevators, elevating platforms, etc.), the brake stops and then **holds the load**.

⚠️ RESTRICTION OF USE IN HOISTING APPLICATION:

According to the standard NF EN 13135 Ed. April, 2013, the starting torque (M_d) as well as pull-up torque (M_a) have to be at least 1.6 times superior at the rated torque (M_n) of the application (Refer to the characteristics tables).

Consequently, the choice of the brake motor has to respect these regulations and is of the responsibility of the integrator of the equipment (release by lever: see p.38).

FAILSAFE BRAKE

It brakes when the power is switched off, and can stop the motor and the driven machine and keep them immobile.

When the brake motor power is switched on, the electromagnet attracts the armature, compresses the springs and releases the brake.

When the brake motor power is switched off, the electromagnet lets the armature go. The thrust from the springs generates friction between the brake disk, the armature and the backplate, resulting in braking.

Braking is brought about by the thrust from springs, hence without external energy input. This is safety braking: it is the most commonly used control mode.

Use with variable speed:

The brake must be supplied separately from the motor. The brake is controlled by the drive (see Installation section).

USING THE BRAKE MOTOR AT CONSTANT TORQUE (0 to 87 Hz)

Using the brake motor with a Δ connection combined with a frequency inverter can increase the constant torque range from 50 to 87 Hz, which increases the power in the same ratio.

The size of the frequency inverter is determined by the current value in 230 V and programmed with a voltage/frequency ratio of 400 V, 87 Hz.

⚠️ Maximum mechanical speed allowed: 4,500 rpm (3,000 rpm with encoder).

See the relevant characteristics pages at 87 Hz, power supply with drive on pages 19, 23, 31.

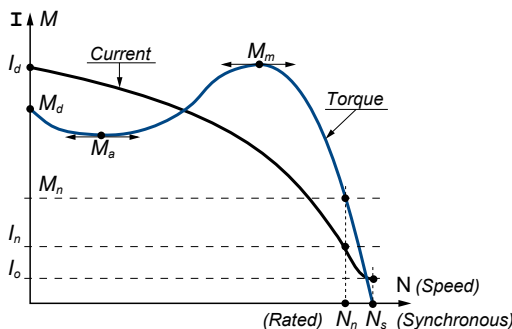
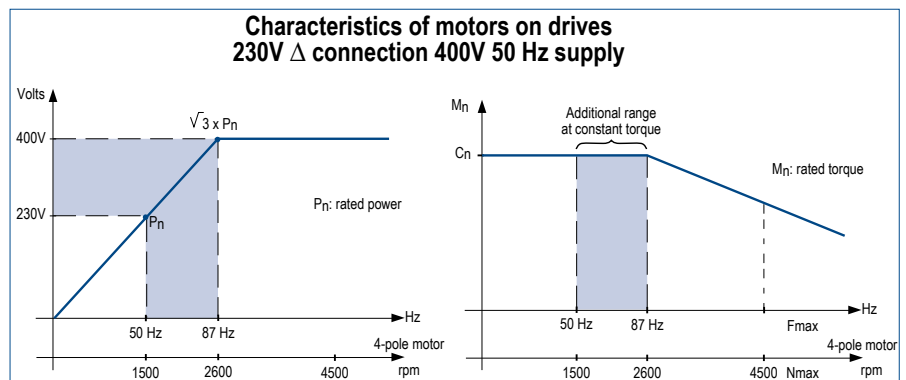

Operation Duty cycle definitions

CONDITIONS AND DUTY CYCLES

CONDITIONS

By condition", we mean all the electrical and mechanical values that typify machine operation at a given time.

DUTY CYCLES

(according to IEC 60034-1)

By duty", we mean the stipulated conditions to which the machine is subjected, their respective durations and order of succession over time.

1 - Continuous duty - Type S1

Operation at constant load of sufficient duration for thermal equilibrium to be reached (see figure 1). 5 starts maximum per hour.

Fig. 1. - Continuous duty. Type S1.

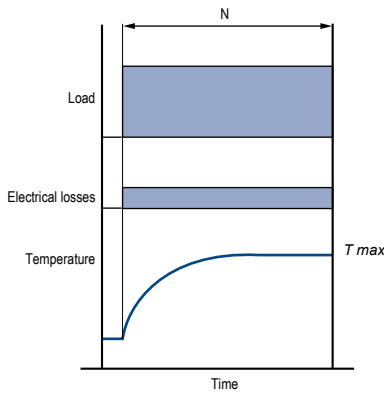

N = operation at constant load

T_{max} = maximum temperature attained

2 - Short-time duty - Type S2

Operation at constant load during a given time, less than that required for thermal equilibrium to be reached, followed by a rest and de-energized period of sufficient duration to re-establish machine temperatures within 2 K of the coolant (see figure 2).

Fig. 2. - Short-time duty. Type S2.

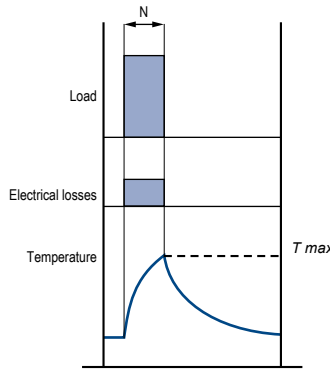

N = operation at constant load

T_{max} = maximum temperature attained

3 - Intermittent periodic duty - Type S3

A sequence of identical duty cycles, each consisting of a period of operation at constant load and a rest and de-energized period (see figure 3). Here, the cycle is such that the starting current does not significantly affect the temperature rise (see figure 3).

Fig. 3. - Intermittent periodic duty. Type S3.

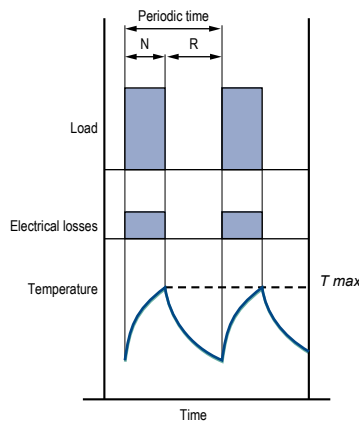

N = operation at constant load

R = rest

T_{max} = maximum temperature attained

$$\text{Operating factor (\%)} = \frac{N}{N + R} \cdot 100$$

4 - Intermittent periodic duty with starting - Type S4

A sequence of identical duty cycles, each consisting of a significant starting period, a period of operation at constant load and a rest and de-energized period (see figure 4).

Fig. 4. - Intermittent periodic duty with starting - Type S4.

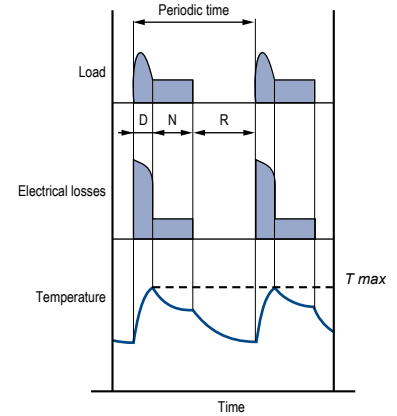

D = starting

N = operation at constant load

R = rest

T_{max} = maximum temperature attained during cycle

$$\text{Operating factor (\%)} = \frac{D + N}{N + R + D} \cdot 100$$

Operation Duty cycle definitions

S4 OPERATING RATES

The different number of starts and driven loads can result in excessive temperature rise in the brake motor.

Select the motor so that $Z_o \geq Z_{oc}$ (Z_o brake motor starting frequency).

Z_{oc} : EQUIVALENT CYCLE STARTING FREQUENCY (h^{-1})

$$Z_{oc} = Z_c \frac{J_c + J_m}{J_m}$$

Z_c : CYCLE STARTING FREQUENCY (h^{-1})

$$Z_c = \frac{n}{t_c}$$

J_m : MOTOR MOMENT OF INERTIA ($kg.m^2$)

J_c : MOMENT OF INERTIA OF THE DRIVEN LOAD ($kg.m^2$)

n : NUMBER OF CYCLE STARTS DURING T

T : TOTAL CYCLE TIME (h)

FM : OPERATING FACTOR (%)

$$FM = \frac{t_m}{T} \times 100$$

t_m : MOTOR RUNNING TIME IN THE CYCLE (h)

S4 DUTY TYPE

For each type of brake motor, the Z_o values are given for **OFs** of 25%, 40%, 60%. These starting frequencies are valid for motors at rated power where $J_c = 0$. They correspond to the standard brake motor.

There are several ways to obtain higher starting frequencies:

- early release
- motor derating
- for special versions, please consult Nidec Leroy-Somer.

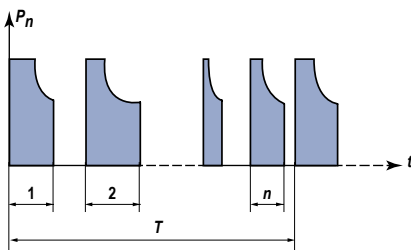

n = Number of starts in a cycle

P_n = Rated motor power

t = Travel time (s)

T = Total cycle time (h)

NO-LOAD STARTING FREQUENCY: Z_o

(For $\Delta T = 100^\circ$, values expressed in h^{-1})

4-pole - 1500 rpm - IFT/NIE (except motors in italics)

Motor type	Brake type	P_n kW	Operating factor		
			25 %	40 %	60 %
<i>LS 71 M</i>	<i>FFB1</i>	0.25	4400	3500	3000
<i>LS 71 M</i>	<i>FFB1</i>	0.37	4400	3500	3000
<i>LS 71 L</i>	<i>FFB1</i>	0.55	4400	3500	3000
LS 80 L	FFB1	0.55	2800	2000	1650
LS 80 L	FFB1	0.75	2800	2000	1650
LS 80 L	FFB1	0.9	2800	2000	1650
LS 90 SL	FFB2	1.1	1400	1200	1000
LS 90 L	FFB2	1.5	1400	1200	1000
LS 90 L	FFB2	1.8	1400	1200	1000
LS 100 L	FFB2	2.2	1200	1000	800
LS 100 L	FFB3	3	1200	1000	800
LS 112 M	FFB3	4	900	800	700
LS 132 S	FFB3	5.5	700	600	500
LS 132 M	FFB4	7.5	350	320	290
LS 132 M	FFB4	9	350	320	290
LS 160 MP	FFB5	11	300	270	250
LS 160 LR	FFB5	15	300	270	250
LS 180 MT	FFB5	18.5	250	220	200

4-pole - 1500 rpm - IFT/IE3 - General use: UG

Motor type	Brake type	P_n kW	Operating factor		
			25 %	40 %	60 %
LSES 80 LG	FFB1	0.75	2000	1500	1000
LSES 80 LG	FFB1	0.9	1200	1000	800
LSES 90 SL	FFB2	1.1	1100	900	800
LSES 90 LU	FFB2	1.5	1000	800	700
LSES 100 L	FFB2	1.8	900	750	650
LSES 100 LR	FFB2	2.2	900	750	650
LSES 100 LG	FFB3	3	800	700	600
LSES 112 MU	FFB3	4	600	500	400
LSES 132 SM	FFB4	5.5	300	280	250
LSES 132 MU	FFB4	7.5	300	280	250
LSES 160 MR	FFB4	9	280	250	220
LSES 160 M	FFB5	11	250	220	200
LSES 160 L	FFB5	15	200	180	150

BRAKE ENERGY CAPACITY

Maximum permissible energy per braking

4-pole motor operating at 50 Hz

E: Energy maxi (Joule)

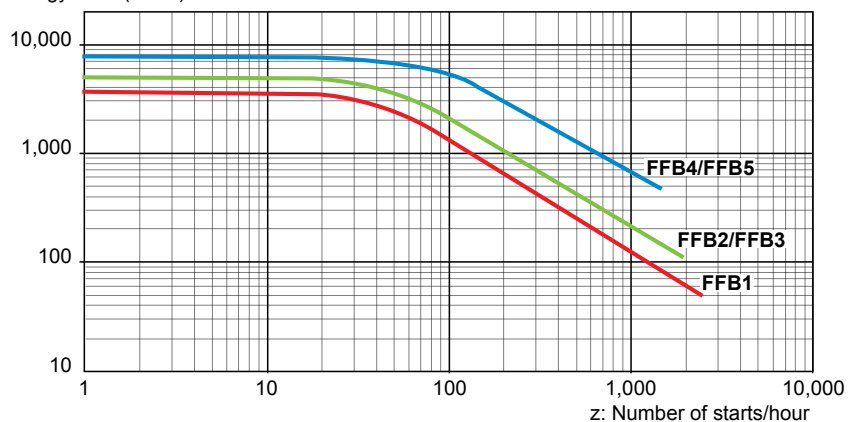

For operation at 60 Hz, the values of above graph should have their classification downgraded of 20%.

Operation Electromagnet characteristics

The DC electromagnet consists of a resin-coated coil in a cast iron yoke. The yoke and the armature form the magnetic circuit. All our coils are made for a DC voltage of 180 VDC (400 or 230 VAC supply) or 20 VDC (24 VAC supply).

All the electromagnets are class F and can be continuously supplied with power. Maximum permissible voltage in S1 duty is 480 V, for any product. Since it is difficult to distinguish between some DC coils by size alone, the coil resistance should be measured with an

appropriately rated ohmmeter and compared with the value given in the table below. These values are theoretical, calculated for an ambient temperature of 20°C.

Electromagnet characteristics ±5%, at 20°C

Brake type	180V coil			20V coil		
	Current A	Resistance Ω	Power W	Current A	Resistance Ω	Power W
FFB1	0.232	776	42	1.974	10.1	39
FFB2	0.295	610	53	2.633	7.6	53
FFB3	0.345	522	62	2.793	7.2	56
FFB4	0.339	530	61	3.602	5.6	72
FFB5	0.547	329	98	4.211	4.8	84

Brake power supply unit characteristics

OPERATING PRINCIPLE

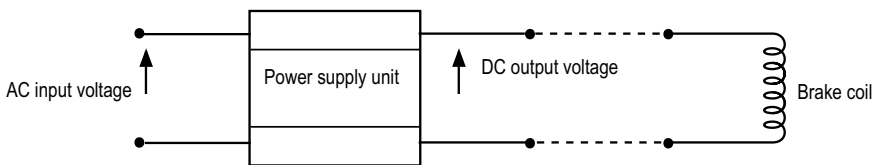

DEFINITION OF BUILT-IN OR SEPARATE POWER SUPPLY

Built-in power supply:

The rectifier power supply unit is connected in parallel on the motor power supply.

Example:

- S08 brake power supply unit, 180 V DC coil for standard single-speed brake motor, direct supply (or separate)

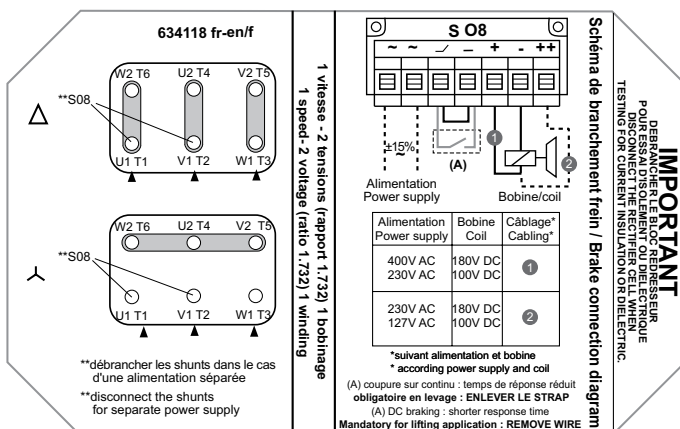

Separate power supply:

The motor and rectifier unit power supplies are independent. It is mandatory for Hoisting applications, as well as variable speed.

Examples:

- S08 brake power supply unit, 180 V DC coil, separate power supply
- S06 brake power supply unit, 20 V DC coil, 24 V separate power supply, below

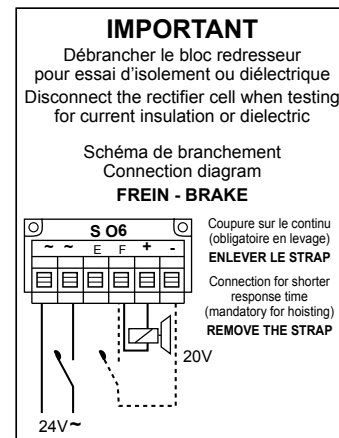

Operation Braking torques

The braking torque M_f is obtained from the friction between a lining made of fibrous composite material and a mating surface. If the braking torque is higher than the highest motor torque, there is a risk of the drivetrain becoming fatigued or breaking. It is therefore advisable to use:

$$M_f = 1.5 \times M_n$$

and never to exceed M_d .

The stated dynamic braking torque is optimum (tolerance from -10 to +40%). A standard is determined as a function of the motor power and its efficiency class: see the selection tables in the

Characteristics Tables section.

A non-standard braking torque is possible as an option (see Optional Braking Torque section).

If you encounter any difficulty relating to standards, please consult Nidec Leroy-Somer.

Influence of the environment

The brake components are treated with anti-corrosion protection to prevent sticking and oxidation of mechanical parts in a damp environment.

FFB brake motors are validated according to EN 60721-3-4

4K2/4Z1/4Z5/4Z7/4B1/4C2/4S2/4M3

Influence of temperature

The heat released during successive braking operations increases the temperature. The resulting reduction in braking torque can be as much as 15% of the rated value.

 **Make sure that the brake motor is compatible with its environment.**

Wear

This is inevitable and requires regular brake adjustment. For each braking operation it is proportional to:

$$0.5 \times (J_m + J_c) \times \omega_N^2$$

It is therefore advisable to avoid braking operations at high rotation speeds (3,000 rpm and above) to reduce the amount of wear.

Wear also occurs, to a lesser extent, on release.

Motor starting and brake release occur simultaneously. For a short time, the braking torque is reduced before reaching zero; this results in brake wear and overheating of the motor. This can be avoided with early release (which consists of releasing the brake before starting the motor, using a time-delay contact).

As an option, when the number of real brakings planned in the life of the product is $\geq 80\%$ of the maximum number of brakings (see § No-load starting frequency), an indicator lamp supplements monitoring. It advises when it is necessary to adjust the air gap or change the lining (see Indicator: release/application, wear section).

Number of braking operations allowed

4-pole¹ - 1500 rpm - IFT/NIE (except motors in italics)

Motor type	Brake type	P _n kW	Maximum number of braking operations before disc replacement (10 ⁶)					Number of braking operations ² before air gap adjustment (10 ⁶)				
			FJ=1	FJ=5	FJ=10	FJ=15	FJ=20	FJ=1	FJ=5	FJ=10	FJ=15	FJ=20
LS 71 M	FFB1	0.25	24.64	8.21	4.48	3.08	2.35	4.93	1.64	0.90	0.62	0.47
LS 71 M	FFB1	0.37	20.87	6.96	3.79	2.61	1.99	4.17	1.39	0.76	0.52	0.40
LS 71 L	FFB1	0.55	17.03	5.68	3.10	2.13	1.62	3.41	1.14	0.62	0.43	0.32
LS 80 L	FFB1	0.55	14.84	4.95	2.70	1.85	1.41	2.97	0.99	0.54	0.37	0.28
LS 80 L	FFB1	0.75	11.24	3.75	2.04	1.41	1.07	2.25	0.75	0.41	0.28	0.21
LS 80 L	FFB1	0.9	8.71	2.90	1.58	1.09	0.83	1.74	0.58	0.32	0.22	0.17
LS 90 SL	FFB2	1.1	11.46	3.82	2.08	1.43	1.09	2.29	0.76	0.42	0.29	0.22
LS 90 L	FFB2	1.5	9.75	3.25	1.77	1.22	0.93	1.95	0.65	0.35	0.24	0.19
LS 90 L	FFB2	1.8	8.67	2.89	1.58	1.08	0.83	1.73	0.58	0.32	0.22	0.17
LS 100 L	FFB2	2.2	7.66	2.55	1.39	0.96	0.73	1.53	0.51	0.28	0.19	0.15
LS 100 L	FFB3	3	6.21	2.07	1.13	0.78	0.59	1.24	0.41	0.23	0.16	0.12
LS 112 M	FFB3	4	5.23	1.74	0.95	0.65	0.50	1.05	0.35	0.19	0.13	0.10
LS 132 S	FFB3	5.5	2.66	0.89	0.48	0.33	0.25	0.53	0.18	0.10	0.07	0.05
LS 132 M	FFB4	7.5	4.91	1.64	0.89	0.61	0.47	0.74	0.25	0.13	0.09	0.07
LS 132 M	FFB4	9	4.23	1.41	0.77	0.53	0.40	0.63	0.21	0.12	0.08	0.06
LS 160 MP	FFB5	11	3.41	1.14	0.62	0.43	0.32	0.51	0.17	0.09	0.06	0.05
LS 160 LR	FFB5	15	2.92	0.97	0.53	0.37	0.28	0.44	0.15	0.08	0.05	0.04
LS 180 MT	FFB5	18.5	2.42	0.81	0.44	0.30	0.23	0.36	0.12	0.07	0.05	0.03

¹ 2 & 6-pole: consult Nidec Leroy-Somer

² for brakes with DLM or DMD option, the number of braking operations prior to the gap adjustment must be divided by 2

4-pole¹ - 1500 rpm - IFT/IE3 - General use: UG

Motor type	Brake type	P _n kW	Maximum number of braking operations before disc replacement (10 ⁶)					Number of braking operations ² before air gap adjustment (10 ⁶)				
			FJ=1	FJ=5	FJ=10	FJ=15	FJ=20	FJ=1	FJ=5	FJ=10	FJ=15	FJ=20
LSES 80 LG	FFB1	0.75	6.42	2.14	1.17	0.80	0.61	1.28	0.43	0.23	0.16	0.12
LSES 80 LG	FFB1	0.9	5.69	1.90	1.03	0.71	0.54	1.14	0.38	0.21	0.14	0.11
LSES 90 SL	FFB2	1.1	7.85	2.62	1.43	0.98	0.75	1.57	0.52	0.29	0.20	0.15
LSES 90 LU	FFB2	1.5	6.48	2.16	1.18	0.81	0.62	1.30	0.43	0.24	0.6	0.12
LSES 100 L	FFB2	1.8	6.11	2.04	1.11	0.76	0.58	1.22	0.41	0.22	0.15	0.12
LSES 100 LR	FFB2	2.2	5.18	1.73	0.94	0.65	0.49	1.04	0.35	0.19	0.13	0.10
LSES 100 LG	FFB3	3	3.19	1.06	0.58	0.40	0.30	0.64	0.21	0.12	0.08	0.06
LSES 112 MU	FFB3	4	2.61	0.87	0.47	0.33	0.25	0.52	0.17	0.09	0.07	0.05
LSES 132 SM	FFB4	5.5	4.30	1.43	0.78	0.54	0.41	0.64	0.21	0.12	0.08	0.06
LSES 132 MU	FFB4	7.5	2.98	0.99	0.54	0.37	0.28	0.45	0.15	0.08	0.06	0.04
LSES 160 MR	FFB4	9	2.59	0.86	0.47	0.32	0.25	0.39	0.13	0.07	0.05	0.04
LSES 160 M	FFB5	11	1.59	0.53	0.29	0.20	0.15	0.24	0.08	0.04	0.03	0.02
LSES 160 L	FFB5	15	1.21	0.40	0.22	0.15	0.11	0.18	0.06	0.03	0.02	0.02

¹ 2 & 6-pole: consult Nidec Leroy-Somer

² for brakes with DLM or DMD option, the number of braking operations prior to the gap adjustment must be divided by 2

Operation Braking torques

Air gap

In order to be able to apply and release the brake, there needs to be displacement of the lining and the armature; this displacement is the air gap. Lining wear must be checked when the air gap is adjusted, by checking the disc thickness

The dimension R must never be lower than following values as this would result in damage including total loss of braking torque, without any warning signs.

Its replacement is mandatory as R dimension reaches the following values:

Brake size	Minimum R dimension
FFB1, FFB2, FFB3	10 mm
FFB4, FFB5	16.5 mm

⚠ Exceeding R dimension can cause security problems (quick decrease of braking torque M_p).

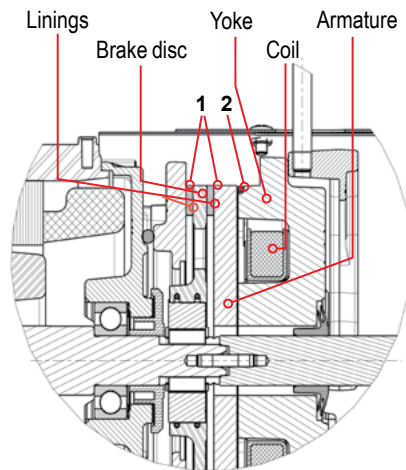

1: air gap with coil energized, brake released
2: air gap with coil de-energized, brake applied

Running-in

The lining allows for a running-in period during which the braking torque is at its maximum value. All the brake linings are run in at the factory prior to assembly on the motor.

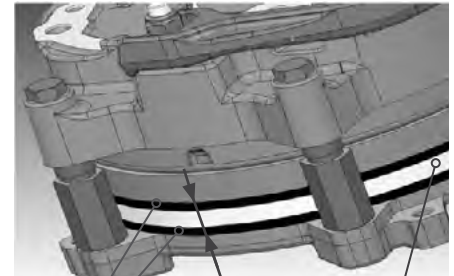

Linings

Rep. 1101

Moments of inertia

The moments of inertia of all our brake motors are given in the characteristics table, in the section with the same name, where J is expressed in $kg.m^2$.

Brake response time and stopping distance

DEFINITION OF RESPONSE TIMES

Brake release response time t_1 :

Time between the moment when the coil is supplied with power and the moment when the armature is in contact with the yoke; this moment is shown on the current curve below as a peak. This interval includes the magnetization time and the armature travel time.

Brake application (engage) response time t_2 :

Time between the moment when the coil power supply is cut and the moment when the armature is in contact with the disk; this moment is shown on the current curve below as a peak. This interval includes the demagnetization time and the armature travel time.

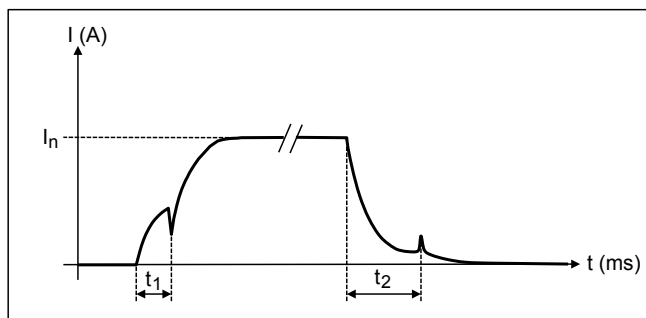

I: current (Amps)

I_n : rated current

t_1 : Release response time (milliseconds ms)

t_2 : Application response time (milliseconds ms)

The brake response time depends on the value of the air gap adjustment. It should therefore be checked regularly (see above)

Option: TRR response time reduced by electronic booster: offered exclusively with built-in power supply and connected at the factory (0.25 to 9 kW).

Using this option allows the frequency of starts to be increased and improves accuracy on stopping by reducing the response time and application time by a third or a half depending on the size of the brake.

In addition, it saves the cost of wiring up a DC switch-off device, which is no longer needed.

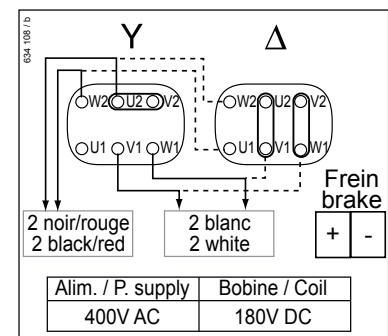

⚠ This option is not compatible with motors for operation on a drive. It is not compatible with separate brake power supply (and built-in power supply on two-speed motors).

Operation Brake response time and stopping distance

RESPONSE TIME VALUES

The response times below are given for a brand-new brake (air gap at its rated value), supplied independently of the motor and at a coil temperature of 20°C ±5 %.

Brake type	M _f N.m	180V coil					20V coil		
		Brake release response time t ₁ (ms)		Response time brake application t ₂ (ms)			Brake release response time t ₁ (ms)		Response time brake application t ₂ (ms)
		Standard	TRR ¹	AC switch-off	DC switch-off	TRR ¹	Standard	AC switch-off	DC switch-off
FFB1	4.5	25	21.2	198	< 5	6.4	28	177	< 5
	6	28	17	159	< 5	8	30	142	< 5
	7.5	30	21	134	< 5	27	32	120	< 5
	9	32	20	117	< 5	15	34	105	< 5
	10.5	34	20	104	< 5	27	36	93	< 5
	12	36	19	94	< 5	26	37	84	< 5
FFB2	11	52	28	416	< 5	20	58	235	< 5
	15	56	33	295	< 5	23	58	178	< 5
	19	59	32	226	< 5	16	57	143	< 5
	23	62	39	182	< 5	36	57	120	< 5
	26	65	40	151	< 5	30	57	103	< 5
	30	67	40	129	< 5	19	57	90	< 5
FFB3	37	85	50	166	< 20	49	75	216	< 5
	45	91	62	132	< 20	46	78	189	< 5
	52	97	62	108	< 20	38	81	168	< 5
	59	102	68	91	< 20	28	84	152	< 5
	67	107	69	79	< 20	27	86	140	< 5
	74	112	66	69	< 20	27	88	129	< 5
FFB4	41	71	50	574	< 10	62	61	248	< 5
	55	82	58	382	< 10	52	72	179	< 5
	69	92	60	278	< 10	38	82	138	< 5
	83	101	70	215	< 10	36	91	112	< 5
	96	109	122	173	< 10	30	99	94	< 5
	110	117	126	143	< 10	38	107	81	< 5
FFB5	120	102	74	517	< 20	68	134	282	< 5
	140	113	76	427	< 20	66	146	236	< 5
	160	123	88	361	< 20	72	157	203	< 5
	180	133	98	311	< 20	32	168	177	< 5
	200	142	96	273	< 20	36	178	157	< 5

1. TRR: Reduced Response Time by booster (p.13)

NOISE LEVEL

The noise levels displayed are the least favorable for values measured in side and axial positions. As a result, in numerous cases, our brake motors perform better. Please consult Nidec Leroy-Somer for actual values, giving any application constraints.

Brake type	M _f N.m	180V coil			20V coil		
		Noise level on brake release dB(A) ¹	Noise level on brake application		Noise level on brake release dB(A) ¹	Noise level on brake application	
			AC switch-off	DC switch-off		AC switch-off	DC switch-off
FFB1	4.5	51	50	58	42	48	58
	6	52	52	60	43	51	60
	7.5	53	54	62	44	54	62
	9	53	55	63	44	57	63
	10.5	54	56	65	45	59	64
	12	54	57	66	45	61	65
FFB2	11	47	32	45	47	32	45
	15	47	33	50	47	33	48
	19	48	34	54	48	34	50
	23	48	34	58	48	34	51
	26	48	35	60	48	35	53
	30	48	35	63	48	35	54
FFB3	37	52	50	61	52	50	61
	45	53	53	63	53	53	63
	52	54	55	65	54	55	65
	59	55	57	66	55	57	66
	67	55	58	67	55	58	67
	74	56	60	68	56	60	68
FFB4	41	60	48	64	60	56	65
	55	60	51	67	61	57	68
	69	60	53	69	63	58	70
	83	60	54	71	64	60	72
	96	60	56	73	64	62	73
	110	60	57	74	65	63	75
FFB5	120	70	49	70	61	57	68
	140	69	51	71	61	59	70
	160	69	53	72	61	61	72
	180	69	54	73	61	63	74
	200	69	56	74	61	64	75

1. Sound pressure shall be measured at 1 metre

STOPPING TIME AND DISTANCE CALCULATIONS

STOPPING TIME (in ms): t_a

$$t_a = t_c + t_2 + t_f$$

t_c: Control device response time (in ms) (see opposite)

t₂: Brake application response time (in ms)

t_f: Brake application response time (in ms)

BRAKING TIME (in s): t_f

$$t_f = \frac{(J_m + J_{c/m})}{M_f \pm M_{R/m}} \cdot \omega_N$$

J_m: Motor moment of inertia (in kgm²)

J_{c/m}: Moment of inertia of the load applied to the brake motor shaft

ω_N: Motor angular speed (in rd/s)

M_f: Brake motor braking torque (in N.m)

M_{R/m}: Load resistive torque (in N.m)

(+ if it is braking, - if it is driving) applied to the brake motor shaft

MOMENT OF INERTIA OF THE LOAD APPLIED TO THE MOTOR SHAFT (kgm²):

J_{c/m}

$$J_{c/m} = J_1 + J_2 \left(\frac{\omega_2}{\omega_N} \right)^2 + m \left(\frac{v}{\omega_N} \right)^2$$

J₁: Moment of inertia rotating at (in kgm²)

ω_N: Motor angular speed (in rd/s)

J₂: Moment of inertia rotating at (in kgm²)

ω₂: Angular speed (in rd/s)

m: Mass travelling at (in kg)

v: Linear speed (in m/s)

STOPPING DISTANCE (in m): l_a

$$l_a = v \left(t_c + t_2 + \frac{t_f}{2} \right)$$

v: Linear speed (in m/s)

t_c, t₂, t_f: Time (in s)

NUMBER OF REVOLUTIONS BEFORE THE MOTORS STOPS (in ms): a

$$a = \frac{\omega_N}{2\pi} \left(t_c + t_2 + \frac{t_f}{2} \right)$$

ω_N: Motor angular speed (in rd/s)

t_c, t₂, t_f: Time (in s)

ACCURACY ON STOPPING (%)

Accuracy on stopping or repeatability of braking depends on many factors: temperature, air gap, brake wear, drivetrain backlash, etc. It is reasonable to assume accuracy on stopping of ±20%.

AC electromagnet, or DC electromagnet with DC switch-off, and taking special care: ±10%.

BRAKE WEAR CALCULATION

INERTIA FACTOR: FJ

$$FJ = \frac{J_{c/m}}{J_m}$$

J_{c/m}: Moment of inertia of the load applied to the brake motor shaft

J_m: Brake motor moment of inertia

Operation Loads applied to the motor (main) shaft

In pulley and belt couplings, the shaft extension carrying the pulley is subjected to a radial force. Formulae and charts can be read in the IMfinity® Motors catalog ref.5147. In the same catalog, the axial force on the shaft can be found for a bearing life L10h of 25,000 and 40,000 hours.

EXAMPLE OF SELECTION

CUSTOMER REQUEST:

Normal, non-corrosive environment,
General applications. 0.75 kW 4p brake motor for motorizing a 15-tonne trolley.

- Linear speed: 15 m/min
- Accuracy on stopping: to be stated
- Safety brake and release by a lever
- Running time: 12 s, stopping: 33 s
- Control device response time: 0.01s
- Drivetrain efficiency: 0.8
- Rolling resistance coefficient $K_r = 0.1$ N/kg
- Mounted on standard flange

CONVERSION TO SI UNITS

$$\omega = 1400 \times \frac{2\pi}{60} = 147 \text{ rad/s}$$

Under load

$$v = \frac{15}{60} = 0.25 \text{ m/s}$$

OPERATION CYCLE

Cycle time

$$T = 12 + 33 = 45 \text{ s}$$

Operating factor

$$OF = \frac{12}{45} = 25 \%$$

STARTING FREQUENCY

$$Z_{oc} = Z_c \times \frac{J_m + J_c}{J_m}$$

$$Z_c = \frac{n}{t_c} = \frac{1}{45/3600} = 80 \text{ h}^{-1}$$

$$J_c = m \times \left(\frac{v}{\omega}\right)^2 = 15,000 \times \left(\frac{0.25}{147}\right)^2 = 0.043 \text{ kgm}^2$$

The flow chart on page 2 leads us to select the FFB brake series. The 4p, 0.75 kW brake motor inertia is:

$$J_m = 0.0019 \text{ kgm}^2 \text{ (see page 18)}$$

$$Z_{oc} = 80 \times \frac{0.0019 + 0.043}{0.0019} = 1890 \text{ h}^{-1}$$

$Z_o \geq Z_{oc}$ (the table on page 10 indicates 2800 d/h-1) for a 4p, 0.75 kW brake motor with non-IE efficiency class (NIE):

4p - LS - 80L - 0.75kW - IM B5 -230/400V
50Hz - UG - FFB1 - 12Nm - + DLRA (auto-return hand brake release)

Code : 4988074

BRAKING TIME

Resistive torque:

$$M_R = m \times k_r \times \frac{v}{\omega} \times \frac{1}{\eta} = 15,000 \times 0.1 \times \frac{0.25}{147} \times \frac{1}{0.8} = 3 \text{ Nm}$$

$$t_f \text{ rated} = (J_m + J_c) \times \frac{\omega_N}{M_f + M_R} = (0.0019 + 0.043) \times \frac{147}{12 + 3} = 0.44 \text{ s}$$

0.44s = rated braking time

for $M_f + 40\% = 17 \text{ Nm} \rightarrow t_f = 0.33 \text{ s}$ (minimum)

for $M_f - 10\% = 11 \text{ Nm} \rightarrow t_f = 0.47 \text{ s}$ (maximum)

STOPPING DISTANCE AND ACCURACY

$$l_a = v \left(t_c + t_2 + \frac{t_f}{2} \right) = 0.25 \times \left(0.01 + 0.094 + \frac{0.44}{2} \right) = 0.0810 \text{ m rated stopping distance}$$

Accuracy on stopping:

for t_f min. 0.33 s $\rightarrow l_a = 0.0673 \text{ m}$ minimum stopping distance

for t_f max. 0.47 s $\rightarrow l_a = 0.0848 \text{ m}$ maximum stopping distance.

NUMBER OF BRAKING OPERATIONS BEFORE ADJUSTMENT

Inertia factor calculation

$$FJ = \frac{J_{c/m}}{J_m} = \frac{0.043}{0.0019} = 22$$

The table on page 12 gives us directly the number of braking operations before adjustment, say for a non-IE 4p, 0.75 kW IFT = $0.21 \times 10^6 = 210,000$ braking operations.

Designation

FFB BRAKE MOTORS - IP55 ALUMINIUM

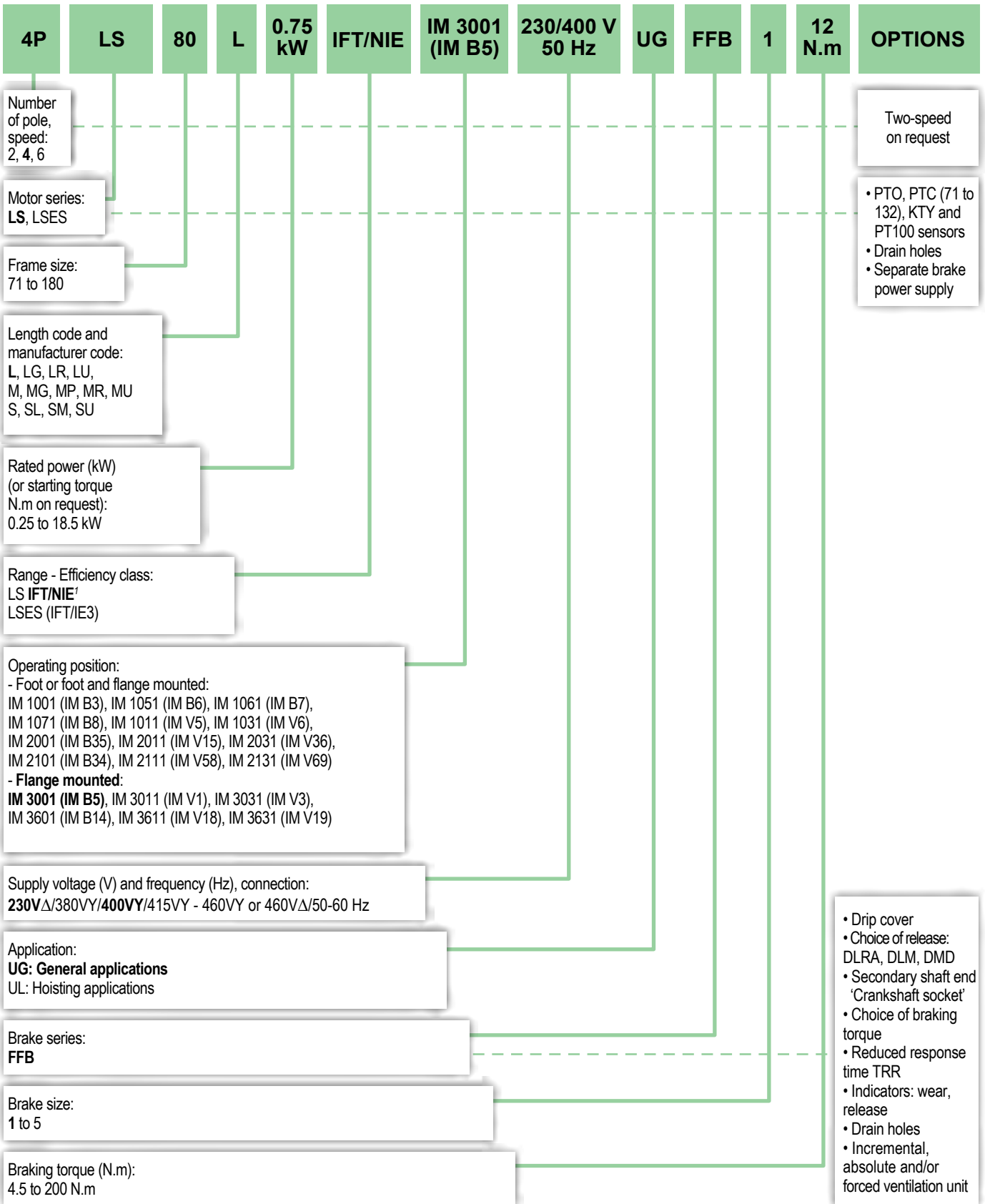

¹ NIE: not in any efficiency class

Description LS (ES) FFB

Description of LS(ES) FFB brake motors

Component	Materials	Comments
Finned housing	Aluminium alloy	- with integral feet (4 fixing holes), or without feet - lifting ring for frame size ≥ 100 - ground terminal with an optional jumper screw
Stator	Insulated low-carbon magnetic steel laminations Electroplated copper	- low carbon content guarantees long-term lamination pack stability - semi-enclosed slots - class F insulation - PTC for motor ≥ frame size 160
Rotor	Insulated low-carbon magnetic steel laminations Aluminium	- inclined cage bars - rotor cage pressure die-cast in aluminium (or alloy for special applications) - rotor balanced dynamically, 1/2 key
Shaft	Steel	- for frame size ≤ 160 MP, LR: • tapped centre hole • closed keyway - for frame size ≥ 160 M, L: • tapped centre hole • open keyway
End shields	Cast iron	- DE and NDE, assembled using tie rods
Bearings		- protected ball bearings, permanently greased - bearings preloaded at non drive end
Lipseals Labyrinth seal	Synthetic rubber	- DE and NDE lipseals or deflectors to ensure IP55 sealing on the shaft - O ring seals to ensure IP55 sealing of the brake (motor NDE shield/backplate, brake disk/splined sleeve, armature/yoke)
Fan	Composite material	- bi-directional: straight blades
Fan cover	Pressed steel	- fitted, on request, with a drip cover for operation in vertical position, shaft end facing down
Terminal box	Aluminium alloy	- IP55, can be turned in 4 directions for flange mounted version, on opposite side from the feet for foot or foot and flange mounted version for frame size ≥ 80 - fitted with a terminal block with 6 steel terminals as standard (brass as an option) - terminal box fitted with threaded plugs (supplied without cable glands) (cable gland as an option) - 1 ground terminal in each terminal box - fixing system consisting of a cover with captive screws
Brake	Cast iron: yoke, backplate, release handle Anti-corrosion hardened steel: armature, screws, release lever Stainless steel: pressure springs, encoder extension Copper: brake coil	FFB: failsafe brake with factory-set braking torque, already run in • 4.5 to 200 N.m of braking torque in accordance with IEC 60034, 60072, EN 50281 • built-in power supply (including brake power supply unit); if it is separate (as an option) the power supply is independent of the motor (including brake power supply unit) • electromagnet encased in plastic to ensure it is fully sealed
External finish		- Shade RAL 6000 (green) - C3L (1 x acrylic polyurethane finish 50µm +/-20%)

From 0.25 to 22 kW in accordance with IEC 60034, as standard brake motors are wound as 230/380/400/415V 50Hz, 460V 60Hz with:

- power ratings ≤ 5.5 kW: Δ connection
- power ratings ≥ 7.5 kW: Δ connection

They are available in 2, 4 and 6-pole versions.

Applications: UG General, UL Hoisting.

Adaptation to variable speed applications:

- LS IFT/NIE, LSES IFT/IE3 cabinet-mounted drive or integrated drive Commander ID300 series (offer on page 3).

Adaptation to particular environments:

- Atex dust (Category 3, zone 22: non conducting dust) autocertification with following marking:

EC  II 3D Ex tc IIIB T125°C

Compliance of the motors with European and international standards:

IEC-EN 60034-1:2010 ; 60034-2-1:2014 ;
60034-8:2007/A1:2014 ;
60034-30-1: 2014
EN 60034-5:2001/A1:2007 ; 60034-6:1993 ;
60034-7:1993/A1:2001 ;
60034-9:2005/A1:2007 ; 60034-14:2004 /
A1:2007 ;
60079-0:2012/A11:2013 ; 60079-31:2014 ;
60529:1991/A1:2000
IEC 60034-5:2000/A1:2006 ; 60034-6:1991 ;
60034-7:1992/A1:2000 ;
60034-9:2003/A1:2007 ; 60034-14:2003/
A1:2007 ; 60072-1:1991 ;
60079-0:2011 ; 60079-31:2013

Equipment and options:

- brake release (auto-return hand release (DLRA), release lock off system (DLM) and remote lock off system (DMD))
- second shaft end 'Crankshaft socket'
- indicator lamps (release and/or wear)
- reduced response time (TRR)
- drain hole (non-standard positions: B3, B5, B14)
- encoder: incremental or absolute, and/or forced ventilation unit.



Characteristics tables

LS FFB IFT/NIE

4-pole - 1500 rpm - IFT/NIE (except motors in italics) - AC power supply

LS FFB brake - 230Δ/380Y/400Y/415Y-460Y or 400V Δ - 50-60 Hz - IP55 - Built-in power supply - Factory-set braking torque

Motor type	Brake type	Rated power P _n kW	Rated torque M _n N.m	Starting torque/ Rated torque M _d /M _n	Maximum torque/ Rated torque M _m /M _n	Starting current/ Rated current I _d /I _n	Moment of inertia J kg.m ²	Pull-up torque M _a N.m	Braking torque ¹ M _f N.m	400V - 50Hz				Weight IM B3/B5 ² kg
										Rated speed N _n rpm	Rated current I _n A	Efficiency IEC 60034-2-1 2007 η % 4/4	Power factor Cos φ 4/4	
<i>LS 71 M</i>	<i>FFB1</i>	0.25	1.68	2.73	2.93	4.63	0.00094	4.60	4.5	1425	0.8	67.0	0.65	9.4
<i>LS 71 M</i>	<i>FFB1</i>	0.37	2.49	2.41	2.81	4.9	0.00111	6.00	4.5	1420	1.06	70.0	0.70	10.3
<i>LS 71 L</i>	<i>FFB1</i>	0.55	3.75	2.32	2.53	4.8	0.00136	8.75	6	1400	1.62	68.0	0.70	11.3
<i>LS 80 L</i>	<i>FFB1</i>	0.55	3.75	2.15	2.3	3.9	0.00154	7.88	12	1405	1.7	66.9	0.71	11.5
<i>LS 80 L</i>	<i>FFB1</i>	0.75	5.1	1.8	2.15	4.25	0.00190	7.40	12	1400	2.05	69.3	0.77	12.2
<i>LS 80 L</i>	<i>FFB1</i>	0.9	6.05	3.1	3.1	5.33	0.00266	17	12	1420	2.55	73.0	0.73	14.8
<i>LS 90 SL</i>	<i>FFB2</i>	1.1	7.35	1.5	2.15	4.5	0.00353	11	19	1425	2.5	76.1	0.84	18.2
<i>LS 90 L</i>	<i>FFB2</i>	1.5	10	1.9	2.4	5.25	0.00425	19	19	1430	3.3	79.2	0.83	20.0
<i>LS 90 L</i>	<i>FFB2</i>	1.8	12	2	2.55	5.6	0.00469	24	26	1435	3.95	79.9	0.82	21.0
<i>LS 100 L</i>	<i>FFB2</i>	2.2	14.6	2.3	2.7	5.7	0.00518	29	26	1435	4.8	80.2	0.82	24.9
<i>LS 100 L</i>	<i>FFB3</i>	3	20	2.6	3.1	6.65	0.00655	50	52	1435	6.35	82.2	0.83	29.1
<i>LS 112 MG</i>	<i>FFB3</i>	4	26.2	3.20	3.19	6.74	0.01240	64	52	1455	8.70	86.9	0.77	29.4
<i>LS 132 S</i>	<i>FFB3</i>	5.5	36.1	2.41	3.06	6.33	0.01538	88	67	1456	11.5	85.4	0.81	44.9
<i>LS 132 M</i>	<i>FFB4</i>	7.5	49.6	2.29	2.99	5.9	0.02523	114	110	1445	15.6	86.8	0.80	62.4
<i>LS 132 M</i>	<i>FFB4</i>	9	59.5	2.4	2.95	6.64	0.0288	128	110	1445	17.7	87.5	0.83	66.3
<i>LS 160 MP</i>	<i>FFB5</i>	11	72.3	2.9	3.3	6.85	0.0338	177	140	1450	22.1	88.8	0.81	83.3
<i>LS 160 LR</i>	<i>FFB5</i>	15	98.4	2.85	3.35	7.45	0.0417	227	180	1456	30	89.1	0.81	96.3
<i>LS 180 MT</i>	<i>FFB5</i>	18.5	121	2.1	3.15	7.95	0.0904	218	200	1464	36	89.3	0.83	117

1. Values given for information only; for standards-related restrictions, please consult Nidec Leroy-Somer.

2. These values are given for information only.

4-pole - 1500 rpm - IFT/NIE - DRIVE power supply

LS FFB brake - 230Δ/380Y/400Y/415Y-460Y or 400V Δ - 50-60 Hz - IP55 - Separate brake power supply - Factory-set braking torque

Motor type	Brake type	Rated power P _n kW	400V - 50Hz			% Rated torque				
			Rated speed N _n rpm	Rated current I _n A	Power factor Cos φ 4/4	M _n at				
						10 Hz	17 Hz	25 Hz	50 Hz	87 Hz
<i>LS 80 L</i>	<i>FFB1</i>	0.75	1380	2.10	0.81	65%	80%	100%	100%	57%
<i>LS 80 L</i>	<i>FFB1</i>	0.9	1415	2.50	0.77	65%	80%	100%	100%	57%
<i>LS 90 SL</i>	<i>FFB2</i>	1.1	1410	2.68	0.87	75%	85%	90%	100%	57%
<i>LS 90 L</i>	<i>FFB2</i>	1.5	1420	3.52	0.86	75%	85%	90%	100%	57%
<i>LS 90 L</i>	<i>FFB2</i>	1.8	1425	4.23	0.85	75%	85%	90%	100%	57%
<i>LS 100 L</i>	<i>FFB2</i>	2.2	1425	5.11	0.86	75%	85%	90%	100%	57%
<i>LS 100 L</i>	<i>FFB3</i>	3	1425	6.78	0.86	60%	85%	90%	100%	57%
<i>LS 112 MG</i>	<i>FFB3</i>	4	1420	9.32	0.84	60%	85%	90%	100%	57%
<i>LS 132 S</i>	<i>FFB3</i>	5.5	1450	11.9	0.86	70%	85%	100%	100%	57%
<i>LS 132 M</i>	<i>FFB4</i>	7.5	1445	15.7	0.82	90%	100%	100%	100%	57%
<i>LS 132 M</i>	<i>FFB4</i>	9	1440	18.8	0.86	90%	100%	100%	100%	57%
<i>LS 160 MP</i>	<i>FFB5</i>	11	1450	22.3	0.83	90%	100%	100%	100%	57%
<i>LS 160 LR</i>	<i>FFB5</i>	15	1450	30.3	0.83	90%	100%	100%	100%	57%
<i>LS 180 MT</i>	<i>FFB5</i>	18.5	1464	36.0	0.83	80%	90%	100%	100%	57%

Characteristics tables

LS FFB IFT/NIE

4-pole - 1500 rpm - IFT/NIE (except motors in italics) - AC power supply

LS FFB brake - 230Δ/380Y/400Y/415Y-460Y or 400V Δ - 50-60 Hz - IP55 - Built-in power supply - Factory-set braking torque

Motor type	Brake type	Rated power P _n kW	380V - 50Hz				415V - 50Hz				460V - 60Hz				
			Rated speed N _n rpm	Rated current I _n A	Efficiency IEC 60034-2-1 2007 η% 4/4	Power factor Cos φ 4/4	Rated speed N _n rpm	Rated current I _n A	Efficiency IEC 60034-2-1 2007 η% 4/4	Power factor Cos φ 4/4	Rated power P _n kW	Rated speed N _n rpm	Rated current I _n A	Efficiency IEC 60034-2-1 2007 η% 4/4	Power factor Cos φ 4/4
LS 71 M	FFB1	0.25	1425	0.78	68.0	0.70	1430	0.84	67.0	0.60	0.30	1684	0.82	68.42	0.77
LS 71 M	FFB1	0.37	1410	1.10	71.0	0.70	1430	1.10	70.0	0.65	0.44	1713	1.05	73.00	0.73
LS 71 L	FFB1	0.55	1385	1.59	68.0	0.75	1410	1.56	68.0	0.70	0.66	1671	1.56	70.60	0.75
LS 80 L	FFB1	0.55	1390	1.65	67.5	0.75	1415	1.75	65.5	0.67	0.63	1710	1.60	71.60	0.70
LS 80 L	FFB1	0.75	1380	2.05	68.3	0.81	1410	2.05	69.0	0.73	0.86	1710	1.95	73.30	0.76
LS 80 L	FFB1	0.9	1405	2.5	74.3	0.74	1430	2.65	73.6	0.64	1.04	1720	2.40	76.70	0.7
LS 90 SL	FFB2	1.1	1410	2.60	74.3	0.87	1435	2.45	76.9	0.82	1.26	1730	2.40	78.80	0.84
LS 90 L	FFB2	1.5	1420	3.40	77.1	0.86	1440	3.25	79.6	0.80	1.72	1735	3.20	81.20	0.83
LS 90 L	FFB2	1.8	1425	4.10	78.8	0.85	1445	4.00	80.7	0.78	2.07	1735	3.90	81.80	0.82
LS 100 L	FFB2	2.2	1425	4.90	79.3	0.86	1445	4.90	80.6	0.78	2.53	1735	4.70	82.40	0.82
LS 100 L	FFB3	3	1425	6.50	81.3	0.86	1440	6.30	82.7	0.80	3.45	1735	6.15	83.80	0.84
LS 112 MG	FFB3	4	1420	8.90	80.9	0.84	1440	9.10	81.4	0.75	4.60	1735	8.70	83.40	0.80
LS 132 S	FFB3	5.5	1450	11.4	85.9	0.86	1458	11.6	85.2	0.77	6.3	1756	11	86.70	0.83
LS 132 M	FFB4	7.5	1440	16.0	85.5	0.83	1450	16.5	86.7	0.73	8.6	1750	14.9	88.00	0.82
LS 132 M	FFB4	9	1435	18.2	87.2	0.86	1452	17.4	89.5	0.81	10.3	1745	17.1	89.40	0.85
LS 160 MP	FFB5	11	1440	22.1	88.0	0.86	1454	21.5	89.3	0.80	12.6	1750	20.9	90.20	0.84
LS 160 LR	FFB5	15	1450	31.0	88.7	0.83	1458	32.2	88.9	0.73	17.2	1756	29.6	90.40	0.81
LS 180 MT	FFB5	18.5	1460	36.9	88.8	0.86	1468	35.7	89.5	0.81	21.0	1762	34	92.10	0.84

4-pole - 1500 rpm - IFT/NIE - DRIVE power supply

LS FFB brake - 230Δ/380Y/400Y/415Y-460Y or 400V Δ - 50-60 Hz - IP55 - Separate brake power supply - Factory-set braking torque

Motor type	Brake type	Rated power P _n kW	400V - 87Hz Δ ¹			Maximum mechanical speed ² rpm
			Rated speed N _n rpm	Rated current I _n A	Power factor Cos φ 4/4	
LS 80 L	FFB1	1.31	2500	3.65	0.81	4500
LS 80 L	FFB1	1.57	2490	4.34	0.77	4500
LS 90 SL	FFB2	1.91	2525	4.66	0.87	4500
LS 90 L	FFB2	2.61	2520	6.13	0.86	4500
LS 90 L	FFB2	3.13	2530	7.36	0.85	4500
LS 100 L	FFB2	3.83	2535	8.90	0.86	4500
LS 100 L	FFB3	5.22	2535	11.8	0.86	4500
LS 112 MG	FFB3	6.96	2535	16.2	0.84	4500
LS 132 S	FFB3	9.57	2530	20.6	0.86	4500
LS 132 M	FFB4	13.1	2560	27.3	0.82	4500
LS 132 M	FFB4	15.7	2555	32.7	0.86	4500
LS 160 MP	FFB5	19.1	2550	38.7	0.83	4500
LS 160 LR	FFB5	26.1	2560	52.7	0.83	4500
LS 180 MT	FFB5	18.5	2560	52.7	0.83	4500

1. Data only applicable to motors: 400V 50Hz Y.

2. with encoder: 3000 rpm

Characteristics tables

LS FFB IFT/NIE

2-pole - 3000 rpm - IFT/NIE (except motors in italics)

LS FFB brake - 230Δ/380Y/400Y/415Y-460Y or 400V Δ - 50-60 Hz - IP55 - Built-in power supply - Factory-set braking torque

Motor type	Brake type	Rated power P _n kW	Rated torque M _n N.m	Starting torque/ Rated torque M _d /M _n	Maximum torque/ Rated torque M _m /M _n	Starting current/ Rated current I _d /I _n	Moment of inertia J kg.m ²	Pull-up torque M _a N.m	Braking torque ¹ M _f N.m	400V - 50Hz				Weight IM B3/B5 ² kg
										Rated speed N _n rpm	Rated current I _n A	Efficiency IEC 60034-2-1 2007 η% 4/4	Power factor Cos φ 4/4	
<i>LS 71 M</i>	<i>FFB1</i>	0.37	1.26	3.30	3.14	5.2	0.00061	4.1	4.5	2800	0.98	68.4	0.82	9.40
<i>LS 71 L</i>	<i>FFB1</i>	0.55	1.88	3.24	2.91	6.0	0.00071	6.1	4.5	2800	1.32	75.7	0.80	10.3
<i>LS 71 L</i>	<i>FFB1</i>	0.75	2.58	3.29	3.92	6.0	0.00086	9	4.5	2780	1.70	77.7	0.84	12.1
<i>LS 80 L</i>	<i>FFB1</i>	0.75	2.55	2.15	2.40	5.05	0.00096	4.46	4.5	2820	1.75	73	0.85	11.2
<i>LS 80 L</i>	<i>FFB1</i>	1.1	3.70	2.35	2.60	5.30	0.00116	7.4	12	2830	2.50	75	0.84	12.7
<i>LS 90 SL</i>	<i>FFB1</i>	1.5	4.95	2.50	3.00	6.10	0.00171	11.6	12	2880	3.35	77.2	0.84	16.5
<i>LS 90 L</i>	<i>FFB2</i>	2.2	7.30	2.75	2.90	6.10	0.00298	18.3	19	2870	4.65	79.7	0.86	21.8
<i>LS 100 L</i>	<i>FFB2</i>	3	10.0	2.85	2.90	6.00	0.00308	25	19	2860	6.45	81.5	0.82	25.7
<i>LS 100 L</i>	<i>FFB2</i>	3.7	12.2	3.65	3.90	8.05	0.00308	36.0	26	2905	7.80	82.7	0.83	31.0
<i>LS 112 M</i>	<i>FFB2</i>	4	13.2	3.55	3.55	7.90	0.00378	38.9	26	2890	8.20	83.1	0.85	31.0
<i>LS 132 S</i>	<i>FFB3</i>	5.5	18.0	2.30	3.15	7.35	0.00878	41.4	52	2925	11.0	84.7	0.85	42.4
<i>LS 132 S</i>	<i>FFB3</i>	7.5	24.4	2.65	3.50	8.33	0.01048	64.7	52	2915	15.8	86	0.86	46.0
<i>LS 132 M</i>	<i>FFB4</i>	9	29.3	2.15	2.95	6.55	0.01703	60.1	96	2935	18.0	86.8	0.83	65.2
<i>LS 160 MP</i>	<i>FFB4</i>	11	35.8	2.20	3.05	6.77	0.01862	71.6	96	2935	22.4	89.2	0.81	76.2
<i>LS 160 MR</i>	<i>FFB4</i>	15	48.8	2.65	3.25	7.81	0.02102	105	96	2935	28.3	90.7	0.86	87.0
<i>LS 160 L</i>	<i>FFB4</i>	18.5	60	2.65	3.36	7.54	0.0500	156	110	2945	28.3	91.8	0.85	115
<i>LS 180 MT</i>	<i>FFB5</i>	22	71.5	2.65	3.20	7.30	0.0580	175	140	2940	28.3	89.9	0.85	122

1. Values given for information only; for standards-related restrictions, please consult Nidec Leroy-Somer.

2. These values are given for information only.

Characteristics tables

LS FFB IFT/NIE

6-pole - 1000 rpm - IFT/NIE (except motors in italics) - AC power supply

LS FFB brake - 230Δ/380Y/400Y/415Y or 400V Δ - 50 Hz - IP55 - Built-in power supply - Factory-set braking torque

Motor type	Brake type	Rated power P _n kW	Rated torque M _n N.m	Starting torque/ Rated torque M _d /M _n	Maximum torque/ Rated torque M _m /M _n	Starting current/ Rated current I _d /I _n	Moment of inertia J kg.m ²	Pull-up torque M _a N.m	Braking torque ¹ M _f N.m	400V - 50Hz				Weight IM B3/B5 ² kg
										Rated speed	Rated current	Efficiency IEC 60034-2-1 2007 η%	Power factor	
										N _n rpm	I _n A	η% 4/4	Cos φ 4/4	
<i>LS 71 L</i>	<i>FFB1</i>	0.25	2.84	1.56	1.6	3.04	0.00156	5.1	4.5	915	1.15	50	0.60	10.9
<i>LS 80 L</i>	<i>FFB1</i>	0.37	3.7	2.1	2.45	3.85	0.00346	7.77	12	954	1.30	61.7	0.66	12.7
<i>LS 80 L</i>	<i>FFB1</i>	0.55	5.5	2.55	2.95	3.4	0.00446	14.0	12	956	2.15	61.0	0.60	14.0
<i>LS 90 SL</i>	<i>FFB2</i>	0.75	7.5	1.9	2.4	3.7	0.00418	13.9	19	952	2.25	70.0	0.68	21.0
<i>LS 90 L</i>	<i>FFB2</i>	1.1	11.2	1.85	2.2	3.85	0.00468	20.7	19	940	3.05	72.9	0.71	22.2
<i>LS 100 L</i>	<i>FFB2</i>	1.5	15.2	1.98	2.28	3.75	0.00525	27.7	26	940	4.00	75.2	0.72	26.5
<i>LS 112 MG</i>	<i>FFB3</i>	2.2	21.9	2.05	2.4	4.75	0.01608	41.6	52	960	5.60	77.7	0.73	37.0
<i>LS 132 S</i>	<i>FFB3</i>	3	29.8	2.35	2.65	5	0.02047	67.1	52	960	7.65	79.7	0.71	45.0
<i>LS 132 M</i>	<i>FFB4</i>	4	39.6	2.15	2.6	5.35	0.03131	79.2	96	964	9.25	81.4	0.77	62.3
<i>LS 132 M</i>	<i>FFB4</i>	5.5	54.4	2.55	2.75	5.6	0.0363	114	96	966	13.1	83.1	0.73	68.5
<i>LS 160 M</i>	<i>FFB5</i>	7.5	73.5	1.7	2.7	5.2	0.0944	110	140	974	17.2	84.7	0.74	77.8
<i>LS 160 L</i>	<i>FFB5</i>	11	109	1.9	2.55	5.23	0.1220	169	180	968	23.7	86.4	0.78	82.8

1. Values given for information only; for standards-related restrictions, please consult Nidec Leroy-Somer.

2. These values are given for information only.

Characteristics tables

LSES FFB IFT/IE3

4-pole - 1500 rpm - IFT/IE3 - AC power supply

LSES FFB brake - 230Δ/380Y/400Y/415Y-460Y or 400V Δ - 50-60 Hz - IP55 - Built-in power supply - Factory-set braking torque

Motor type	Brake type	Rated power P _n kW	Rated torque M _n N.m	Starting torque/ Rated torque M _d /M _n	Maximum torque/ Rated torque M _m /M _n	Starting current/ Rated current I _d /I _n	Moment of inertia J kg.m ²	Pull-up torque M _a N.m	Braking torque ² M _f N.m	400V - 50Hz				Weight IM B3/B5 ² kg
										Rated speed	Rated current	Efficiency IEC 60034-2-1 2007 η% 4/4	Power factor Cos φ 4/4	
										N _n rpm	I _n A			
LSES 80 LG	FFB1	0.75	4.95	2.20	2.95	6.39	0.0036	10.9	12	1450	1.6	83.6	0.81	16.6
LSES 80 LG	FFB1	0.9	5.9	2.58	3.08	6.26	0.0041	13.2	12	1452	1.95	83.8	0.79	16.7
LSES 90 SL	FFB2	1.1	7.25	2.45	3.2	6.90	0.0051	16.3	19	1450	2.3	84.8	0.81	22.4
LSES 90 LU	FFB2	1.5	9.85	2.90	3.7	7.65	0.0061	26.6	19	1452	3.2	85.6	0.79	26.6
LSES 100 L	FFB2	1.8	11.8	2.41	2.73	6.42	0.0065	26.8	26	1456	3.8	86.6	0.79	29.9
LSES 100 LR	FFB2	2.2	14.4	3.20	3.75	7.96	0.0076	46.1	26	1454	4.65	87.1	0.78	32.0
LSES 100 LG	FFB3	3	19.6	2.45	3.25	7.21	0.0124	46.1	52	1464	6	89.2	0.81	36.1
LSES 112 MU	FFB3	4	26.2	2.70	3.1	7.23	0.0140	56.3	52	1456	7.9	88.9	0.82	43.6
LSES 132 SM	FFB4	5.5	35.9	2.80	3.6	8.39	0.0289	96.9	69	1462	10.5	90.3	0.84	66.5
LSES 132 MU	FFB4	7.5	49.1	2.95	3.35	8.12	0.0356	133	110	1458	13.8	90.4	0.87	77.1
LSES 160 MR	FFB4	9	58.7	3.10	3.65	8.69	0.0418	158	110	1464	17	91	0.84	92.3
LSES 160 M	FFB5	11	71.7	2.25	3.05	7.36	0.0772	133	140	1466	20.2	91.4	0.86	110
LSES 160 L	FFB5	15	97.3	2.95	3.95	9.25	0.1014	185	180	1472	28.3	92.2	0.83	117

1. Values given for information only; for standards-related restrictions, please consult Nidec Leroy-Somer.

2. These values are given for information only.

4-pole - 1500 rpm - IFT/IE3 - DRIVE power supply

LSES FFB brake - 230Δ/380Y/400Y/415Y-460Y or 400V Δ - 50-60 Hz - IP55 - Separate brake power supply - Factory-set braking torque

Motor type	Brake type	Rated power P _n kW	400V - 50Hz			% Rated torque				
			Rated speed	Rated current	Power factor	M _n at				
			N _n rpm	I _n A	Cos φ 4/4	10 Hz	17 Hz	25 Hz	50 Hz	87 Hz
LSES 80 LG	FFB1	0.75	1450	1.70	0.80	90%	100%	100%	100%	57%
LSES 80 LG	FFB1	0.9	1440	2.45	0.80	90%	100%	100%	100%	57%
LSES 90 SL	FFB2	1.1	1450	2.43	0.81	90%	100%	100%	100%	57%
LSES 90 LU	FFB2	1.5	1452	3.31	0.79	90%	100%	100%	100%	57%
LSES 100 L	FFB2	1.8	1440	3.90	0.82	90%	100%	100%	100%	57%
LSES 100 LR	FFB2	2.2	1454	4.77	0.79	90%	100%	100%	100%	57%
LSES 100 LG	FFB3	3	1460	6.37	0.81	90%	100%	100%	100%	57%
LSES 112 MU	FFB3	4	1458	8.37	0.80	90%	100%	100%	100%	57%
LSES 132 SM	FFB4	5.5	1462	11.0	0.85	90%	90%	100%	100%	57%
LSES 132 MU	FFB4	7.5	1458	14.9	0.86	90%	90%	100%	100%	57%
LSES 160 MR	FFB4	9	1464	17.8	0.85	90%	90%	100%	100%	57%
LSES 160 M	FFB5	11	1466	21.6	0.85	85%	95%	100%	100%	57%
LSES 160 L	FFB5	15	1468	30.0	0.85	85%	95%	100%	100%	57%

Characteristics tables

LSES FFB IFT/IE3

4-pole - 1500 rpm - IFT/IE3 - AC power supply

LSES FFB brake - 230Δ/380Y/400Y/415Y-460Y or 400V Δ - 50-60 Hz - IP55 - Built-in power supply - Factory-set braking torque

Motor type	Brake type	Rated power P _n kW	380V - 50Hz				415V - 50Hz				Rated power P _n kW	460V - 60Hz			
			Rated speed N _n rpm	Rated current I _n A	Efficiency IEC 60034-2-1 2007 η% 4/4	Power factor Cos φ 4/4	Rated speed N _n rpm	Rated current I _n A	Efficiency IEC 60034-2-1 2007 η% 4/4	Power factor Cos φ 4/4		Rated speed N _n rpm	Rated current I _n A	Efficiency IEC 60034-2-1 2007 η% 4/4	Power factor Cos φ 4/4
LSES 80 LG	FFB1	0.75	1440	1.65	82.6	0.82	1452	1.60	83.7	0.78	0.75	1758	1.45	85.1	0.77
LSES 80 LG	FFB1	0.9	1440	2.00	83.0	0.82	1452	1.80	83.6	0.78	0.9	1758	1.70	85.6	0.76
LSES 90 SL	FFB2	1.1	1445	2.35	84.1	0.83	1454	2.30	85.4	0.79	1.1	1760	2.05	86.6	0.78
LSES 90 LU	FFB2	1.5	1445	3.25	85.3	0.82	1456	3.20	85.8	0.77	1.5	1760	2.80	87.3	0.76
LSES 100 L	FFB2	1.8	1445	3.90	85.4	0.83	1454	3.90	86.2	0.79	1.8	1760	3.30	87.0	0.78
LSES 100 LR	FFB2	2.2	1445	4.70	86.7	0.82	1456	4.60	87.3	0.77	2.2	1760	4.15	88.4	0.76
LSES 100 LG	FFB3	3	1452	6.20	87.7	0.84	1462	6.05	88.4	0.78	3	1766	5.35	90.0	0.79
LSES 112 MU	FFB3	4	1450	8.30	88.6	0.83	1462	8.05	88.9	0.78	4	1764	7.10	90.2	0.79
LSES 132 SM	FFB4	5.5	1456	10.7	89.64	0.87	1466	10.2	90.4	0.83	5.5	1768	9.05	91.7	0.83
LSES 132 MU	FFB4	7.5	1450	14.5	90.4	0.87	1462	13.6	90.9	0.85	7.5	1766	12.1	92.0	0.84
LSES 160 MR	FFB4	9	1458	17.4	90.6	0.86	1466	16.5	91.5	0.83	9	1768	14.7	92.4	0.83
LSES 160 M	FFB5	11	1462	21.1	91.4	0.86	1470	19.8	91.9	0.84	11	1774	17.8	92.8	0.84
LSES 160 L	FFB5	15	1468	29.1	92.1	0.85	1474	28.3	92.2	0.80	15	1776	25.6	93.2	0.79

4-pole - 1500 rpm - IFT/IE3 - DRIVE power supply

LSES FFB brake - 230Δ/380Y/400Y/415Y-460Y or 400V Δ - 50-60 Hz - IP55 - Separate brake power supply - Factory-set braking torque

Motor type	Brake type	Rated power P _n kW	400V - 87Hz Δ ¹			Maximum mechanical speed ² rpm
			Rated speed N _n rpm	Rated current I _n A	Power factor Cos φ 4/4	
LSES 80 LG	FFB1	1.31	2511	2.96	0.80	4500
LSES 80 LG	FFB1	1.55	2550	3.47	0.80	4500
LSES 90 SL	FFB2	1.91	2511	4.23	0.81	4500
LSES 90 LU	FFB2	2.61	2514	5.76	0.79	4500
LSES 100 L	FFB2	3.13	2550	6.77	0.82	4500
LSES 100 LR	FFB2	3.83	2518	8.30	0.79	4500
LSES 100 LG	FFB3	5.22	2528	11.1	0.81	4500
LSES 112 MU	FFB3	6.96	2525	14.6	0.80	4500
LSES 132 SM	FFB4	9.57	2532	19.1	0.85	4500
LSES 132 MU	FFB4	13.1	2525	25.9	0.86	4500
LSES 160 MR	FFB4	15.7	2535	31.0	0.85	4500
LSES 160 M	FFB5	19.1	2538	37.6	0.85	4500
LSES 160 L	FFB5	26.1	2542	50.8	0.85	4500

1. Data only applicable to motors: 400V 50Hz Y.

2. with encoder: 3000 rpm

Characteristics tables

LSES FFB IFT/IE3

2-pole - 3000 rpm - IFT/IE3 - AC power supply

LSES FFB brake - 230Δ/380Y/400Y/415Y-460Y or 400V Δ - 50-60 Hz - IP55 - Built-in power supply - Factory-set braking torque

Motor type	Brake type	Rated power	Rated torque	Starting torque/ Rated torque	Maximum torque/ Rated torque	Starting current/ Rated current	Moment of inertia	Pull-up torque	Braking torque ¹	400V - 50Hz				Weight IM B3/B5 ² kg
		P _n kW	M _n N.m	M _d /M _n	M _m /M _n	I _d /I _n	J kg.m ²	M _a N.m	M _f N.m	Rated speed N _n rpm	Rated current I _n A	Efficiency IEC 60034-2-1 2007 η% 4/4	Power factor Cos φ 4/4	
LSES 80 L	FFB1	0.75	2.50	3.45	3.45	7.75	0.00121	7.75	4.5	2890	1.6	82.4	0.83	12.9
LSES 80 LG	FFB1	1.1	3.65	2.65	3.25	7.00	0.00249	8.94	12	2885	2.2	85.6	0.85	17.1
LSES 90 SL	FFB1	1.5	4.95	2.95	3.25	7.45	0.00254	13.6	12	2890	3	85.3	0.84	18.6
LSES 90 L	FFB1	1.8	5.95	3.11	3.39	7.52	0.00323	17.3	12	2900	3.75	85.6	0.81	20.8
LSES 90 LU	FFB2	2.2	7.25	3.10	3.40	8.00	0.00380	21.0	19	2895	4.25	86.9	0.86	26.6
LSES 100 L	FFB2	3	10	3.53	3.43	8.35	0.00452	33.3	19	2885	5.8	87.1	0.86	30.8
LSES 100 LG	FFB2	3.7	12.1	2.08	3.02	7.39	0.01028	25.2	26	2930	6.7	89.3	0.89	41.4
LSES 112 MG	FFB2	4	13.1	2.00	2.90	7.01	0.01028	26.2	26	2920	7.2	89.0	0.90	38.9
LSES 132 S	FFB3	5.5	18.0	2.30	3.05	7.55	0.0120	37.8	52	2925	10.1	89.4	0.88	45.8
LSES 132 SM	FFB4	7.5	24.4	2.10	2.90	6.8	0.0171	48.8	55	2935	13.8	91.2	0.86	70.2
LSES 132 M	FFB4	9	29.2	2.15	3.25	7.65	0.0181	62.8	96	2945	16.7	91.7	0.85	73.8
LSES 160 MP	FFB4	11	35.7	1.90	2.90	6.95	0.0199	66.1	96	2940	19.9	91.5	0.87	84.5
LSES 160 M	FFB4	15	48.6	2.30	2.75	7.86	0.0550	97.2	96	2945	26.5	91.9	0.89	110
LSES 160 L	FFB4	18.5	59.9	2.80	3.15	7.60	0.0611	138	110	2950	32.8	92.6	0.88	115
LSES 180 MR	FFB5	22	71.1	3.15	3.15	8.67	0.0688	167	140	2954	38.7	93.2	0.88	127

1. Values given for information only; for standards-related restrictions, please consult Nidec Leroy-Somer.

2. These values are given for information only.

6-pole - 1000 rpm - IFT/IE3 - AC power supply

LSES FFB brake - 230Δ/380Y/400Y/415Y or 400V Δ - 50 Hz - IP55 - Built-in power supply - Factory-set braking torque

Motor type	Brake type	Rated power	Rated torque	Starting torque/ Rated torque	Maximum torque/ Rated torque	Starting current/ Rated current	Moment of inertia	Pull-up torque	Braking torque ¹	400V - 50Hz				Weight IM B3/B5 ² kg
		P _n kW	M _n N.m	M _d /M _n	M _m /M _n	I _d /I _n	J kg.m ²	M _a N.m	M _f N.m	Rated speed N _n rpm	Rated current I _n A	Efficiency IEC 60034-2-1 2007 η% 4/4	Power factor Cos φ 4/4	
LSES 90 SL	FFB2	0.75	7.5	1.86	2.3	4.34	0.00466	13.6	19	952	1.95	79.2	0.71	22.2
LSES 90 LU	FFB2	1.1	11	2.35	2.7	4.85	0.00607	24.8	19	956	2.75	81.9	0.70	27.7
LSES 100 LG	FFB2	1.5	14.8	2.35	2.8	5.65	0.01610	28.9	26	966	3.6	83.8	0.72	36.2
LSES 112 MU	FFB3	2.2	21.7	2.30	2.75	5.45	0.01986	45.6	52	966	5.4	84.3	0.70	43.6
LSES 132 SM	FFB4	3	29.5	2.75	3.15	6.6	0.03131	67.9	55	972	6.8	87.5	0.73	54.6
LSES 132 M	FFB4	4	39.3	2.65	2.9	6.41	0.03630	82.5	96	972	9.05	87.4	0.73	68.5
LSES 132 MU	FFB4	5.5	54.4	2.60	2.85	6.4	0.0429	120	96	966	11.7	88.1	0.77	77.6
LSES 160 MU	FFB5	7.5	73.2	2.0	3.05	6.93	0.1355	124	140	978	16.1	89.6	0.75	99.3

1. Values given for information only; for standards-related restrictions, please consult Nidec Leroy-Somer.

2. These values are given for information only.

IMfinity® LS FFB - LSES FFB - FLSES FFB brake motors

IP 55 Aluminium housing

LS(ES) FFB dimensions

Foot mounted IM B3 (IM 1001)

Dimensions in millimeters

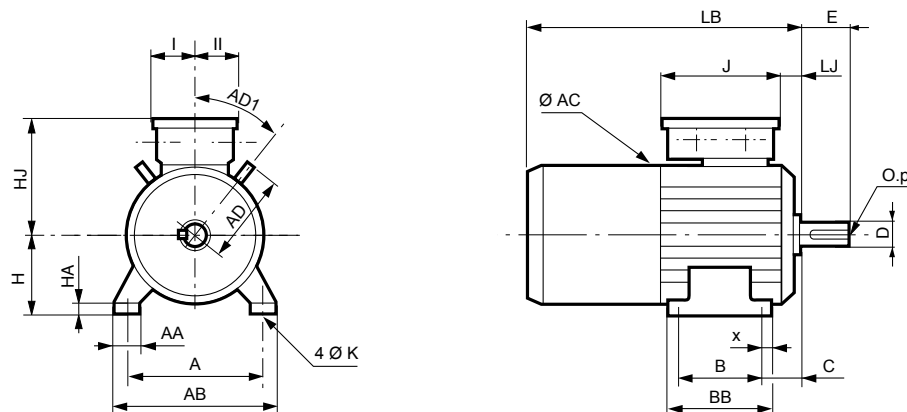

Motor type	Brake type	Main dimensions																		
		A	AA	AB	AC ¹	AD	AD1	B	BB	C	H	HA	HJ	J	I	II	K	LB	LJ	x
LS 71 M	FFB1	112	23	126	140	-	-	90	104	45	71	9	130	160	55	55	7	286	12	7.5
LS 71 L	FFB1	112	23	126	140	-	-	90	104	45	71	9	130	160	55	55	7	296	12	7.5
LS 80 L	FFB1	125	29	157	170	-	-	100	120	50	80	10	141	160	55	55	9	312	13.5	10
LSES 80 L	FFB1	125	29	157	170	-	-	100	120	50	80	10	141	160	55	55	9	312	13.5	10
LSES 80 LG	FFB1	125	31	157	190	-	-	100	125	50	80	10	151	160	55	55	9	389	13.5	14
LS 90 L	FFB2	140	39	172	190	-	-	125	164	56	90	11	151	160	55	55	10	389	13.5	28
LS 90 SL	FFB1, 2	140	39	172	190	-	-	125	164	56	90	11	151	160	55	55	10	389	13.5	28
LSES 90 SL	FFB1, 2	140	39	172	190	-	-	125	164	56	90	11	151	160	55	55	10	389	13.5	28
LSES 90 L	FFB1	140	39	172	190	-	-	125	164	56	90	11	151	160	55	55	10	389	13.5	28
LSES 90 LU	FFB2	140	39	172	190	-	-	125	164	56	90	11	151	160	55	55	10	389	13.5	28
LS 100 L	FFB2, 3	160	40	196	200	118	45	140	165	63	100	13	156	160	55	55	12	437	14.5	12
LSES 100 L	FFB2	160	40	196	200	118	45	140	165	63	100	13	156	160	55	55	12	437	14.5	12
LSES 100 LR	FFB2	160	40	196	200	118	45	140	165	63	100	13	156	160	55	55	12	437	14.5	12
LSES 100 LG	FFB2, 3	160	49	196	235	-	-	140	170	63	100	13	165	160	55	55	12	423	23.5	11
LS 112 M	FFB2	190	45	220	200	118	45	140	165	70	112	14	156	160	55	55	12	437	14.5	13
LS 112 MG	FFB3	190	52	220	235	-	-	140	165	70	112	14	165	160	55	55	12	448	23.5	12
LSES 112 MG	FFB2	190	52	220	235	-	-	140	165	70	112	14	165	160	55	55	12	448	23.5	12
LSES 112 MU	FFB3	190	52	220	235	-	-	140	165	70	112	14	165	160	55	55	12	448	23.5	12
LS 132 S	FFB3	216	42	250	227	130	45	140	170	89	132	16	168	160	55	55	16	490	40.5	16
LSES 132 S	FFB3	216	42	250	227	130	45	140	170	89	132	16	168	160	55	55	12	490	40.5	16
LSES 132 SM	FFB4	216	50	250	272	140	45	140	208	89	132	15	186	160	55	55	12	596	25	15
LS 132 M	FFB4	216	50	250	272	140	45	178	208	89	132	15	186	160	55	55	12	596	25	15
LSES 132 M	FFB4	216	50	250	272	140	45	178	208	89	132	15	186	160	55	55	12	596	25	15
LSES 132 MU	FFB4	216	50	250	272	140	45	178	208	89	132	15	186	160	55	55	12	596	25	15
LS 160 MP	FFB4, 5	254	64	294	272	156	45	210	294	108	160	25	186	160	55	55	14	671	66.5	20
LSES 160 MP	FFB4	254	64	294	272	156	45	210	294	108	160	25	186	160	55	55	14	671	66.5	20
LS 160 MR	FFB4	254	64	294	272	156	45	210	294	108	160	25	186	160	55	55	14	671	66.5	20
LSES 160 MR	FFB4	254	64	294	272	156	45	210	294	108	160	25	186	160	55	55	14	671	66.5	20
LS 160 LR	FFB5	254	64	294	272	156	45	254	294	108	160	25	186	160	55	55	14	671	66.5	20
LS 160 M	FFB5	254	60	294	312	186	45	210	294	108	160	25	248	186	112	98	14.5	682	42	20
LSES 160 M	FFB4, 5	254	60	294	312	-	-	254	294	108	160	25	248	186	112	98	14.5	682	42	20
LS 160 L	FFB4	254	60	294	312	186	45	254	294	108	160	25	248	186	112	98	14.5	682	42	20
LSES 160 L	FFB4, 5	254	60	294	312	-	-	254	294	108	160	25	248	186	112	98	14.5	682	42	20
LSES 160 MU	FFB5	254	60	294	312	-	-	254	294	108	160	25	248	186	112	98	14.5	677	42	20
LS 180 MT	FFB5	279	79	324	312	186	45	241	316	121	180	28	248	186	112	98	14.5	682	42	20
LSES 180 MR	FFB5	279	79	324	312	-	-	279	316	121	180	28	248	186	112	98	14.5	677	42	20

1. Housing diameter without lifting rings

Motor type	Brake type	Output shaft details										
		D	E	F	G	GD	L	LO	rs	ts	ts1	M.OxP
LS 71	FFB1	14j6	30	5	11	5	25	4	-	-	-	M5x15
LS(ES) 80	FFB1, 2	19j6	40	6	15.5	6	30	6	0.5	2	20	M6x16
LS(ES) 90	FFB1, 2	24j6	50	8	20	7	40	6	0.5	2	20	M8x19
LS(ES) 100	FFB2, 3	28j6	60	8	24	7	50	6	0.5	2	20	M10x22
LS(ES) 112	FFB2, 3	28j6	60	8	24	7	50	6	0.5	2	20	M10x22
LS(ES) 132	FFB3, 4	38k6	80	10	33	8	63	10	0.5	2	20	M12x28
LS(ES) 160	FFB4, 5	42k6	110	12	37	8	100	6	0.8	1	45	M16x36
LS(ES) 180	FFB5	48k6	110	14	42.5	9	98	12	0.8	1	45	M16x36

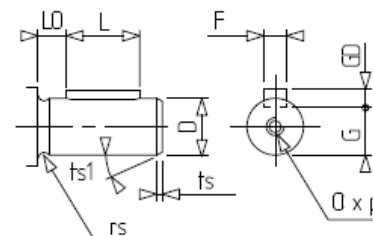

IMfinity® LS FFB - LSES FFB - FLSES FFB brake motors

IP 55 Aluminium housing

LS(ES) FFB dimensions

Flange mounted (FF) IM B5 (IM 3001)

Dimensions in millimeters

FFB BRAKE MOTORS - IP55 ALUMINIUM

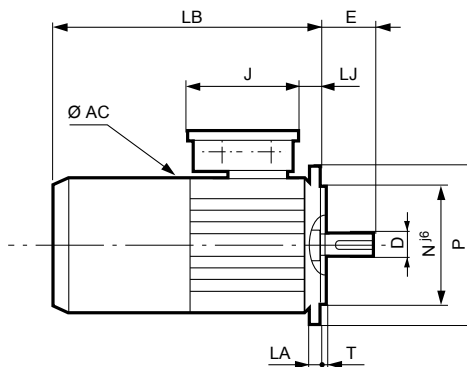
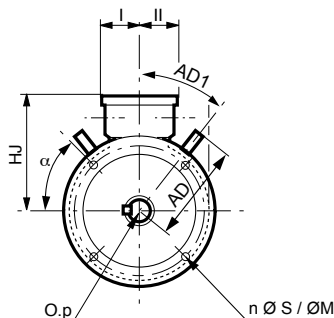

Motor type	Brake type	Main dimensions								
		AC ¹	AD	AD1	HJ	J	I	II	LB	LJ
LS 71 M	FFB1	140	-	-	130	160	55	55	286	12
LS 71 L	FFB1	140	-	-	130	160	55	55	296	12
LS 80 L	FFB1	170	-	-	141	160	55	55	312	14.5
LSES 80 L	FFB1	170	-	-	141	160	55	55	312	13.5
LSES 80 LG	FFB1	185	-	-	151	160	55	55	409	34.5
LS 90 L	FFB2	190	-	-	151	160	55	55	409	33
LS 90 SL	FFB1, 2	190	-	-	151	160	55	55	409	33.5
LSES 90 SL	FFB1, 2	190	-	-	151	160	55	55	409	33.5
LSES 90 L	FFB1	190	-	-	151	160	55	55	409	33.5
LSES 90 LU	FFB2	190	-	-	151	160	55	55	409	33.5
LS 100 L	FFB2, 3	200	-	-	156	160	55	55	437	14.5
LSES 100 L	FFB2	200	-	-	156	160	55	55	437	14.5
LSES 100 LR	FFB2	200	-	-	156	160	55	55	437	14.5
LSES 100 LG	FFB2, 3	235	-	-	165	160	55	55	423	13.5
LS 112 M	FFB2	200	-	-	156	160	55	55	437	14.5
LS 112 MG	FFB3	235	-	-	165	160	55	55	448	23.5
LSES 112 MG	FFB2	235	-	-	165	160	55	55	448	23.5
LSES 112 MU	FFB3	235	-	-	165	160	55	55	448	23.5
LS 132 S	FFB3	220	130	45	168	160	55	55	490	40.5
LSES 132 S	FFB3	220	130	45	168	160	55	55	490	40.5
LSES 132 SM	FFB4	265	140	45	186	160	55	55	621	50
LS 132 M	FFB4	265	140	45	186	160	55	55	596	25
LSES 132 M	FFB4	265	140	45	186	160	55	55	596	25
LSES 132 MU	FFB4	265	140	45	186	160	55	55	596	25
LS 160 MP	FFB4, 5	264	155	45	186	160	55	55	671	66.5
LSES 160 MP	FFB4	264	155	45	186	160	55	55	671	66.5
LS 160 MR	FFB4	264	155	45	186	160	55	55	671	66.5
LSES 160 MR	FFB4	264	155	45	186	160	55	55	671	66.5
LS 160 LR	FFB5	264	155	45	186	160	55	55	671	66.5
LS 160 M	FFB5	312	-	-	248	186	112	98	682	42
LSES 160 M	FFB4, 5	312	-	-	248	186	112	98	682	42
LS 160 L	FFB4, 5	312	-	-	248	186	112	98	682	42
LSES 160 L	FFB4, 5	312	-	-	248	186	112	98	682	42
LSES 160 MU	FFB5	312	-	-	248	186	112	98	677	42
LS 180 MT	FFB5	312	-	-	248	186	112	98	682	42
LSES 180 MR	FFB5	312	-	-	248	186	112	98	677	42

IEC symbol	Flange (FF) output dimensions							
	M	N	P	n	α°	S	T	LA
FF130	130	110	160	4	45	10	3.5	10
FF130	130	110	160	4	45	10	3.5	10
FF165	165	130	200	4	45	12	3.5	10
FF165	165	130	200	4	45	12	3.5	10
FF165	165	130	200	4	45	12	3.5	10
FF165	165	130	200	4	45	12	3.5	10
FF165	165	130	200	4	45	12	3.5	10
FF165	165	130	200	4	45	12	3.5	10
FF165	165	130	200	4	45	12	3.5	10
FF215	215	180	250	4	45	14.5	4	12
FF215	215	180	250	4	45	14.5	4	10
FF215	215	180	250	4	45	14.5	4	10
FF215	215	180	250	4	45	14.5	4	13
FF215	215	180	250	4	45	15	4	12
FF215	215	180	250	4	45	15	4	12
FF215	215	180	250	4	45	15	4	12
FF215	215	180	250	4	45	15	4	12
FF265	265	230	300	4	45	14.5	4	14
FF265	265	230	300	4	45	14.5	4	14
FF265	265	230	300	4	45	14.5	4	14
FF265	265	230	300	4	45	14.5	4	14
FF265	265	230	300	4	45	14.5	4	14
FF300	300	250	350	4	45	18.5	5	14
FF300	300	250	350	4	45	18.5	5	15
FF300	300	250	350	4	45	18.5	5	14
FF300	300	250	350	4	45	18.5	5	15
FF300	300	250	350	4	45	18.5	5	15
FF300	300	250	350	4	45	18.5	5	15
FF300	300	250	350	4	45	18.5	5	15
FF300	300	250	350	4	45	18.5	5	15
FF300	300	250	350	4	45	18.5	5	15

1. Housing diameter without lifting rings

Motor type	Brake type	Output shaft details										
		D	E	F	G	GD	L	LO	rs	ts	ts1	M.Oxp
LS 71	FFB1	14/6	30	5	11	5	25	4	-	-	-	M5x12.4
LS(ES) 80	FFB 1, 2	19/6	40	6	15.5	6	30	6	0.5	2	20	M6x16
LS(ES) 90	FFB 1, 2	24/6	50	8	20	7	40	6	0.5	2	20	M8x19
LS(ES) 100	FFB 2, 3	28/6	60	8	24	7	50	6	0.5	2	20	M10x22
LS(ES) 112	FFB 2, 3	28/6	60	8	24	7	50	6	0.5	2	20	M10x22
LS(ES) 132	FFB 3, 4	38k6	80	10	33	8	63	10	0.5	2	20	M12x28
LS(ES) 160	FFB 4, 5	42k6	110	12	37	8	100	6	0.8	1	45	M16x36
LS(ES) 180	FFB5	48k6	110	14	42.5	9	98	12	0.8	1	45	M16x36

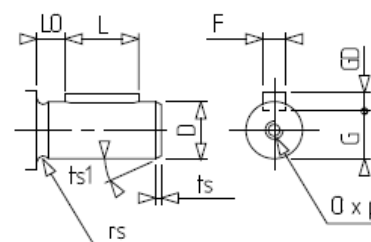

IMfinity® LS FFB - LSES FFB - FLSES FFB brake motors
 IP 55 Aluminium housing
LS(ES) FFB dimensions
 Face mounted (FT) IM B14 (IM 3601)

Dimensions in millimeters

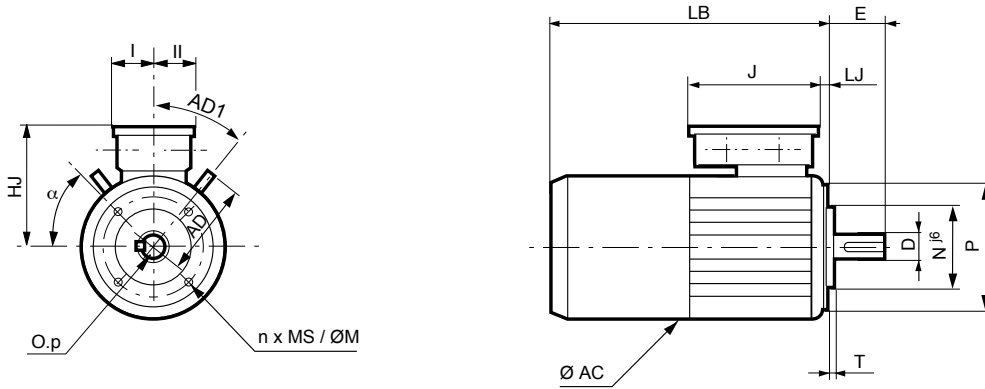

Motor type	Brake type	Main dimensions								
		AC ¹	AD	AD1	HJ	J	I	II	LB	LJ
LS 71 M	FFB1	140	-	-	130	160	55	55	286	12
LS 71 L	FFB1	140	-	-	130	160	55	55	286	12
LS 80 L	FFB1	170	-	-	141	160	55	55	312	14.5
LSES 80 L	FFB1	170	-	-	141	160	55	55	312	14.5
LSES 80 LG	FFB1	185	-	-	151	160	55	55	389	13.5
LS 90 L	FFB2	190	-	-	151	160	55	55	389	13.5
LS 90 SL	FFB1, 2	190	-	-	151	160	55	55	389	13.5
LSES 90 SL	FFB1, 2	190	-	-	151	160	55	55	389	13.5
LSES 90 L	FFB1	190	-	-	151	160	55	55	389	13.5
LSES 90 LU	FFB2	190	-	-	151	160	55	55	389	13.5
LS 100 L	FFB2, 3	200	-	-	156	160	55	55	437	14.5
LSES 100 L	FFB2	200	-	-	156	160	55	55	437	14.5
LSES 100 LR	FFB2	200	-	-	140	160	55	55	437	14.5
LSES 100 LG	FFB2, 3	235	-	-	165	160	55	55	423	13.5
LS 112 M	FFB2	200	-	-	156	160	55	55	437	14.5
LS 112 MG	FFB3	235	-	-	165	160	55	55	448	23.5
LSES 112 MG	FFB2	235	-	-	165	160	55	55	448	23.5
LSES 112 MU	FFB3	235	-	-	165	160	55	55	448	23.5
LS 132 S	FFB3	220	130	45	168	160	55	55	490	40.5
LSES 132 S	FFB3	220	130	45	168	160	55	55	490	40.5
LSES 132 SM	FFB4	265	140	45	186	160	55	55	596	25
LS 132 M	FFB4	265	140	45	186	160	55	55	596	25
LSES 132 M	FFB4	265	140	45	186	160	55	55	596	25
LSES 132 MU	FFB4	265	140	45	186	160	55	55	596	25
LS 160 MP	FFB4, 5	264	155	45	186	160	55	55	671	66.5
LSES 160 MP	FFB4	264	155	45	186	160	55	55	671	66.5
LS 160 MR	FFB4	264	155	45	186	160	55	55	671	66.5
LSES 160 MR	FFB4	264	155	45	186	160	55	55	671	66.5

IEC symbol	Faceplate (FT) output dimensions						
	M	N	P	n	α°	MS	T
FT85	85	70	105	4	45°	M6	2.5
FT85	85	70	105	4	45°	M6	2.5
FT100	100	80	120	4	45°	M6	3
FT100	100	80	120	4	45°	M6	3
FT100	100	80	120	4	45°	M6	3
FT115	115	95	140	4	45°	M8	3
FT115	115	95	140	4	45°	M8	3
FT115	115	95	140	4	45°	M8	3
FT115	115	95	140	4	45°	M8	3
FT115	115	95	140	4	45°	M8	3
FT130	130	110	160	4	45°	M8	3.5
FT130	130	110	160	4	45°	M8	3.5
FT130	130	110	160	4	45°	M8	3.5
FT130	130	110	160	4	45°	M8	3.5
FT130	130	110	160	4	45°	M8	3.5
FT130	130	110	160	4	45°	M8	3.5
FT130	130	110	160	4	45°	M8	3.5
FT130	130	110	160	4	45°	M8	3.5
FT165	165	130	200	4	45°	M10	3.5
FT165	165	130	200	4	45°	M10	3.5
FT165	165	130	200	4	45°	M10	3.5
FT165	165	130	200	4	45°	M10	3.5
FT165	165	130	200	4	45°	M10	3.5
FT215	215	180	250	4	45°	M12	4
FT215	215	180	250	4	45°	M12	4
FT215	215	180	250	4	45°	M12	4
FT215	215	180	250	4	45°	M12	4
FT215	215	180	250	4	45°	M12	4

1. Housing diameter without lifting rings

Motor type	Brake type	Output shaft details										
		D	E	F	G	GD	L	LO	rs	ts	ts1	M.OxP
LS 71	FFB1	14j6	30	5	11	5	25	4	-	-	-	M5x12.4
LS(ES) 80	FFB 1, 2	19j6	40	6	15.5	6	30	6	0.5	2	20	M6x16
LS(ES) 90	FFB 1, 2	24j6	50	8	20	7	40	6	0.5	2	20	M8x19
LS(ES) 100	FFB 2, 3	28j6	60	8	24	7	50	6	0.5	2	20	M10x22
LS(ES) 112	FFB 2, 3	28j6	60	8	24	7	50	6	0.5	2	20	M10x22
LS(ES) 132	FFB 3, 4	38k6	80	10	33	8	63	10	0.5	2	20	M12x28
LS(ES) 160	FFB 4, 5	42k6	110	12	37	8	100	6	0.8	1	45	M16x36

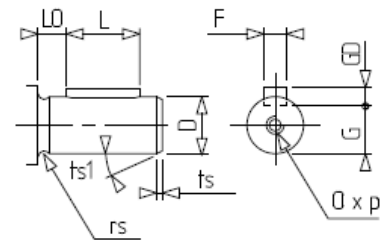

FFB BRAKE MOTORS - IP55 ALUMINIUM

Designation

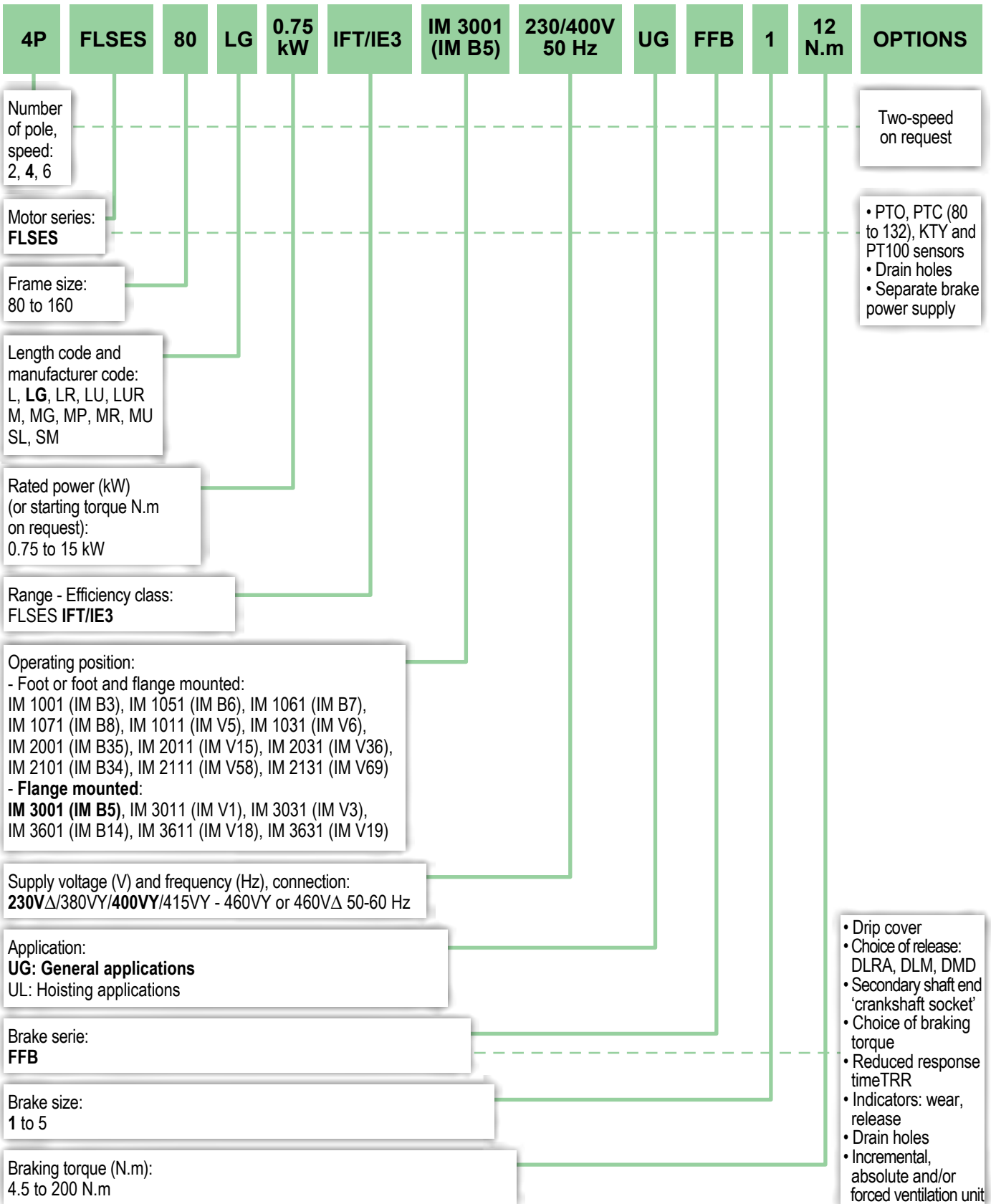

FFB BRAKE MOTORS - IP55 CAST IRON

Description

Description of FLSES FFB brake motors

Component	Materials	Comments
Finned housing	Cast iron	- with integral feet (4 fixing holes), or without feet - lifting ring for frame size ≥ 100 - ground terminal with an optional jumper screw
Stator	Insulated low-carbon magnetic steel laminations Electroplated copper	- low carbon content guarantees long-term lamination pack stability - semi-enclosed slots - class F insulation
Rotor	Insulated low-carbon magnetic steel laminations Aluminium	- inclined cage bars - rotor cage pressure die-cast in aluminium (or alloy for special applications) - rotor balanced dynamically, 1/2 key
Shaft	Steel	- for all frame sizes ≤ 132 : • closed keyway • tapped centre hole - for frame sizes ≤ 160 : • open keyway • tapped centre hole
End shields	Cast iron	- DE and NDE, assembled using tie rods
Bearings		- protected ball bearings, permanently greased - bearings preloaded at non drive end
Lipseals Labyrinth seal	Synthetic rubber	- labyrinth seal at drive end for foot mounted motors, frame size ≤ 132 - lipseal at drive end for foot and flange mounted or flange mounted motors, frame size ≤ 132 - DE and NDE lipseal for frame size 160
Fan	Composite material	- bi-directional: straight blades
Fan cover	Pressed steel	- fitted, on request, with a drip cover for operation in vertical position, shaft end facing down
Terminal box	Cast iron body and cover	- IP55 - fitted with a terminal block with 6 terminals - terminal box fitted with threaded plugs (brass cable glands as an option) - 1 ground terminal in each terminal box - fixing system consisting of a cover with captive screws
Brake	Cast iron: yoke, backplate, release handle Anticorrosion hardened steel: armature, screws, release lever Stainless steel: pressure springs, encoder extension Copper: brake coil	FFB: failsafe brake with factory-set braking torque, already run in • 4.5 to 200 N.m of braking torque in accordance with IEC 60034, 60072, EN 50281 • built-in power supply (including brake power supply unit); if it is separate (as an option) the power supply is independent of the motor (including brake power supply unit) • electromagnet encased in plastic to ensure it is fully sealed
External finish		- Shade RAL 6000 (green) - C3L (1 x acrylic polyurethane finish 50 μ m +/-20%)

From 0.75 to 18.5 kW in accordance with IEC 60034, as standard brake motors are wound as 230/380/400/415V 50Hz, 460V 60Hz with:

- power ratings ≤ 5.5 kW: Δ connection
- power ratings ≥ 7.5 kW: Δ connection

They are available in 2, 4 and 6-pole versions.

Applications: UG General, UL Hoisting

Adaptation to variable speed applications:

- FLSES IFT/IE3 serie Cabinet-mounted drive (offer on page 3).

Adaptation to particular environments:

- Atex dust (Category 3, zone 22: non conducting dust) autocertification with following marking:

EC  II 3D Ex tc IIIB T125°C Dc

Compliance of the motors with European and international standards:

IEC-EN 60034-1:2010 ; 60034-2-1:2014 ; 60034-8:2007/A1:2014 ; 60034-30-1: 2014
EN 60034-5:2001/A1:2007 ; 60034-6:1993 ; 60034-7:1993/A1:2001 ;
60034-9:2005/A1:2007 ; 60034-14:2004/A1:2007 ;
60079-0:2012/A11:2013 ; 60079-31:2014 ; 60529:1991/A1:2000
IEC 60034-5:2000/A1:2006 ; 60034-6:1991 ; 60034-7:1992/A1:2000 ;
60034-9:2003/A1:2007 ; 60034-14:2003/A1:2007 ; 60072-1:1991 ; 60079-0:2011 ; 60079-31:2013.

Equipment and options:

- brake release (auto-return hand release (DLRA), release lock off system (DLM) and remote lock off system (DMD))
- second shaft end 'Crankshaft socket'
- indicator lamps (release, wear)
- reduced response time (TRR)
- drain hole (non-standard positions: B3, B5, B14)
- encoder: incremental or absolute, and/or forced ventilation unit.

Characteristics tables

FLSES FFB IFT/IE3

4-pole - 1500 rpm - IFT/IE3 - AC power supply

FLSES FFB brake - 230Δ/380Y/400Y/415Y-460Y or 400V Δ - IP55 - Built-in power supply - Factory-set braking torque

Motor type	Brake type	Rated power P _n kW	Rated torque M _n N.m	Starting torque/ Rated torque M _d /M _n	Maximum torque/ Rated torque M _m /M _n	Starting current/ Rated current I _d /I _n	Moment of inertia J kg.m ²	Pull-up torque M _a N.m	Braking torque ⁷ M _f N.m	400V - 50Hz				Weight IM B3/B5 ² kg
										Rated speed N _n rpm	Rated current I _n A	Efficiency IEC 60034-2-1 2007 η% 4/4	Power factor Cos φ 4/4	
FLSES 80 LG	FFB1	0.75	4.95	2.2	3.15	6.6	0.00361	14.1	12	1452	1.65	83.8	0.79	25.0
FLSES 90 SL	FFB2	1.1	7.25	2.4	3.2	7.5	0.00506	16.0	19	1450	2.3	84.9	0.81	30.8
FLSES 90 LU	FFB2	1.5	9.85	2.85	3.55	7.34	0.00612	27.1	19	1454	3.25	85.4	0.78	34.4
FLSES 100 LR	FFB2	2.2	14.5	3.45	3.85	8.16	0.00764	46.4	26	1452	4.65	86.9	0.78	42.6
FLSES 100 LG	FFB3	3	19.6	2.45	3.25	7.27	0.0124	46.1	52	1462	5.95	88.7	0.82	47.3
FLSES 112 MU	FFB3	4	26.2	2.7	3.1	7.05	0.0152	1.9	52	1458	8.1	88.8	0.80	55.3
FLSES 132 SM	FFB4	5.5	35.9	2.85	3.65	8.35	0.0289	98.7	67	1462	10.5	90.1	0.84	85.4
FLSES 132 MR	FFB4	7.5	49.1	2.8	3.4	8.45	0.0391	132.6	110	1460	13.8	90.6	0.86	104
FLSES 160 M	FFB4	9	58.5	2.35	3.05	8.25	0.0661	96.5	110	1468	16.7	91.2	0.85	120
FLSES 160 M	FFB5	11	71.7	2.25	2.85	7.6	0.0772	122	140	1466	20.1	91.7	0.86	132
FLSES 160LUR	FFB5	15	97.4	2.3	3.2	8.0	0.1014	195	180	1470	27.2	92.3	0.86	157

1. Values given for information only; for standards-related restrictions, please consult Nidec Leroy-Somer.

2. These values are given for information only.

4-pole - 1500 rpm - IFT/IE3 - DRIVE power supply

FLSES FFB brake - 230Δ/380Y/400Y/415Y-460Y or 400V Δ - IP55 - Separate brake power supply - Factory-set braking torque

Motor type	Brake type	Rated power P _n kW	400V - 50Hz			% Rated torque				
			Rated speed N _n rpm	Rated current I _n A	Power factor Cos φ 4/4	M _n at				
						10 Hz	17 Hz	25 Hz	50 Hz	87 Hz
FLSES 80 LG	FFB1	0.75	1450	1.7	0.80	90%	100%	100%	100%	57%
FLSES 90 SL	FFB2	1.1	1450	2.3	0.81	90%	100%	100%	100%	57%
FLSES 90 LU	FFB2	1.5	1454	3.20	0.79	90%	100%	100%	100%	57%
FLSES 100 LR	FFB2	2.2	1452	4.60	0.79	90%	100%	100%	100%	57%
FLSES 100 LG	FFB3	3	1460	6.10	0.81	90%	100%	100%	100%	57%
FLSES 112 MU	FFB3	4	1458	8.10	0.80	90%	100%	100%	100%	57%
FLSES 132 SM	FFB4	5.5	1462	10.5	0.84	90%	90%	100%	100%	57%
FLSES 132 MR	FFB4	7.5	1460	13.8	0.86	90%	90%	100%	100%	57%
FLSES 160 M	FFB4	9	1462	17.9	0.87	90%	90%	100%	100%	57%
FLSES 160 M	FFB5	11	1466	20.1	0.86	85%	95%	100%	100%	57%
FLSES 160 LUR	FFB5	15	1470	27.5	0.85	85%	95%	100%	100%	57%

Characteristics tables

FLSES FFB IFT/IE3

4-pole - 1500 rpm - IFT/IE3 - AC power supply

FLSES FFB brake - 230Δ/380Y/400Y/415Y-460Y or 400V Δ - IP55 - Built-in power supply - Factory-set braking torque

Motor type	Brake type	Rated power P _n kW	380V - 50Hz				415V - 50Hz				Rated power P _n kW	460V - 60Hz			
			Rated speed N _n rpm	Rated current I _n A	Efficiency IEC 60034-2-1 2007 η% 4/4	Power factor Cos φ 4/4	Rated speed N _n rpm	Rated current I _n A	Efficiency IEC 60034-2-1 2007 η% 4/4	Power factor Cos φ 4/4		Rated speed N _n rpm	Rated current I _n A	Efficiency IEC 60034-2-1 2007 η% 4/4	Power factor Cos φ 4/4
FLSES 80 LG	FFB1	0.75	1445	1.65	83.1	0.82	1454	1.6	84	0.78	1.31	1762	1.45	85.7	0.76
FLSES 90 SL	FFB2	1.1	1440	2.35	84.1	0.83	1454	2.3	84.9	0.79	1.91	1758	2.05	86.5	0.78
FLSES 90 LU	FFB2	1.5	1445	3.25	85.3	0.81	1456	3.2	85.6	0.76	2.62	1762	2.9	86.9	0.75
FLSES 100 LR	FFB2	2.2	1445	4.75	86.7	0.81	1456	4.65	87.1	0.76	3.83	1762	4.1	88.3	0.76
FLSES 100 LG	FFB3	3	1456	6.15	88.3	0.84	1462	5.95	88.8	0.79	5.22	1768	5.2	89.9	0.8
FLSES 112 MU	FFB3	4	1458	8.30	88.6	0.83	1462	8.05	89.4	0.78	6.96	1764	7.65	85.5	0.77
FLSES 132 SM	FFB4	5.5	1456	10.9	89.6	0.86	1466	10.3	90.2	0.82	9.57	1768	9.2	91.7	0.82
FLSES 132 MR	FFB4	7.5	1456	14.3	90.4	0.88	1464	13.5	91.0	0.85	13.1	1768	12.1	92.0	0.85
FLSES 160 M	FFB4	9	1462	17.3	90.9	0.87	1472	16.5	91.6	0.83	15.7	1772	14.6	92.4	0.84
FLSES 160 M	FFB5	11	1462	21.0	91.4	0.87	1468	19.5	92.2	0.85	19.1	1772	17.5	92.9	0.85
FLSES 160 LUR	FFB5	15	1466	28.6	92.1	0.87	1474	26.8	92.6	0.84	26.1	1774	23.8	93.4	0.85

4-pole - 1500 rpm - IFT/IE3 - DRIVE power supply

FLSES FFB brake - 230Δ/380Y/400Y/415Y-460Y or 400V Δ - IP55 - Separate brake power supply - Factory-set braking torque

Motor type	Brake type	Rated power P _n kW	400V - 87Hz Δ ¹			Maximum mechanical speed ² rpm
			Rated speed N _n rpm	Rated current I _n A	Power factor Cos φ 4/4	
FLSES 80 LG	FFB1	1.31	2545	3.13	0.80	4500
FLSES 90 SL	FFB2	1.91	2540	4.47	0.81	4500
FLSES 90 LU	FFB2	2.61	2545	6.08	0.79	4500
FLSES 100 LR	FFB2	3.83	2550	8.76	0.79	4500
FLSES 100 LG	FFB3	5.22	2555	11.71	0.81	4500
FLSES 112 MU	FFB3	6.96	2550	15.37	0.80	4500
FLSES 132 SM	FFB4	9.57	2560	20.19	0.84	4500
FLSES 132 MR	FFB4	13.1	2555	27.34	0.86	4500
FLSES 160 M	FFB4	15.7	2572	31.20	0.87	4500
FLSES 160 M	FFB5	19.1	2564	39.49	0.86	4500
FLSES 160 LUR	FFB5	26.1	2568	53.43	0.85	4500

1. Data only applicable to motors: 400V 50Hz Y.

2. with encoder: 3000 rpm

Characteristics tables

FLSES FFB IFT/IE3

2-pole - 3000 rpm - IFT/IE3 - AC power supply

FLSES FFB brake - 230Δ/380Y/400Y/415Y-460Y or 400V Δ - IP55 - Built-in power supply - Factory-set braking torque

Motor type	Brake type	Rated power	Rated torque	Starting torque/ Rated torque	Maximum torque/ Rated torque	Starting current/ Rated current	Moment of inertia	Pull-up torque	Braking torque ¹	400V - 50Hz				Weight IM B3/B5 ²
										Rated speed	Rated current	Efficiency IEC 60034-2-1 2007	Power factor	
		P _n kW	M _n N.m	M _d /M _n	M _m /M _n	I _d /I _n	J kg.m ²	M _a N.m	M _f N.m	N _n rpm	I _n A	η% 4/4	Cos φ 4/4	kg
FLSES 80 L	FFB1	0.75	2.5	2.8	3.6	7	0.00121	8.88	4.5	2885	1.6	82.6	0.82	19.2
FLSES 80 LG	FFB1	1.1	3.65	2.45	3.15	6.8	0.00227	9.67	12	2885	2.2	85.6	0.85	25.5
FLSES 90 SL	FFB1	1.5	4.95	2.9	3	7	0.00253	13.1	12	2890	3	85.1	0.85	27.6
FLSES 90 LU	FFB2	2.2	7.25	3.4	3.25	8.15	0.00380	21.8	19	2895	4.25	87.0	0.86	34.4
FLSES 100 L	FFB2	3	9.9	3.2	3.6	8.1	0.00452	25.7	19	2895	5.75	87.1	0.86	41.3
FLSES 112 MG	FFB2	4	13.1	2.1	2.95	7.34	0.01028	23.6	26	2920	7.3	88.5	0.89	51.0
FLSES 132 SM	FFB4	5.5	17.9	2	2.8	6.4	0.01101	34.0	55	2935	10.3	90.0	0.86	70.5
FLSES 132 SM	FFB4	7.5	24.4	2.05	2.9	6.95	0.01705	47.6	55	2940	13.8	91.2	0.86	89.1
FLSES 132 M	FFB4	9	29.2	2.45	3.2	7.55	0.0181	62.8	96	2940	16.8	91.3	0.85	92.7
FLSES 160 M	FFB4	11	35.6	3.34	3.04	8.24	0.0772	97.6	96	2950	19.9	91.9	0.87	127
FLSES 160 M	FFB4	15	48.6	2.9	2.9	7.3	0.0611	112	96	2950	26.7	92.4	0.88	148
FLSES 160 LUR	FFB4	18.5	59.9	2.85	2.75	7.4	0.0686	120	110	2950	32.9	92.5	0.88	150

1. Values given for information only; for standards-related restrictions, please consult Nidec Leroy-Somer.

2. These values are given for information only.

6-pole - 1000 rpm - IFT/IE3 - AC power supply

FLSES FFB brake - 230Δ/380Y/400Y/415Y or 400V Δ - IP55 - Built-in power supply - Factory-set braking torque

Motor type	Brake type	Rated power	Rated torque	Starting torque/ Rated torque	Maximum torque/ Rated torque	Starting current/ Rated current	Moment of inertia	Pull-up torque	Braking torque ¹	400V - 50Hz				Weight IM B3/B5 ²
										Rated speed	Rated current	Efficiency IEC 60034-2-1 2007	Power factor	
		P _n kW	M _n N.m	M _d /M _n	M _m /M _n	I _d /I _n	J kg.m ²	M _a N.m	M _f N.m	N _n rpm	I _n A	η% 4/4	Cos φ 4/4	kg
FLSES 90 SL	FFB2	0.75	7.55	1.84	2.3	4.45	0.00466	13.6	19	950	1.9	79.1	0.72	30.4
FLSES 90 LU	FFB2	1.1	11	2.25	2.55	4.8	0.00607	23.1	19	954	2.75	81.7	0.71	35.5
FLSES 100 LG	FFB2	1.5	14.8	2.35	2.8	5.65	0.01610	30.3	26	966	3.6	83.8	0.72	47.5
FLSES 112 MU	FFB3	2.2	21.7	2.25	2.75	5.6	0.01986	47.7	52	968	5.35	84.5	0.70	55.6
FLSES 132 SM	FFB4	3	29.5	2.65	3.05	6.4	0.0313	62.0	55	972	6.8	87.3	0.73	81.3
FLSES 132 M	FFB4	4	39.4	2.4	2.9	6.27	0.0363	82.7	96	970	9.2	86.9	0.72	87.2
FLSES 132 MU	FFB4	5.5	54.4	2.65	2.8	6.36	0.0429	112	96	966	11.7	88.3	0.77	97
FLSES 160 MU	FFB5	7.5	73.2	2	3.05	6.45	0.1355	124	140	978	17.4	89.5	0.77	134

1. Values given for information only; for standards-related restrictions, please consult Nidec Leroy-Somer.

2. These values are given for information only.

IMfinity® LS FFB - LSES FFB - FLSES FFB brake motors

IP 55 Cast iron housing

FLSES FFB dimensions

Foot mounted IM B3 (IM 1001)

Dimensions in millimeters

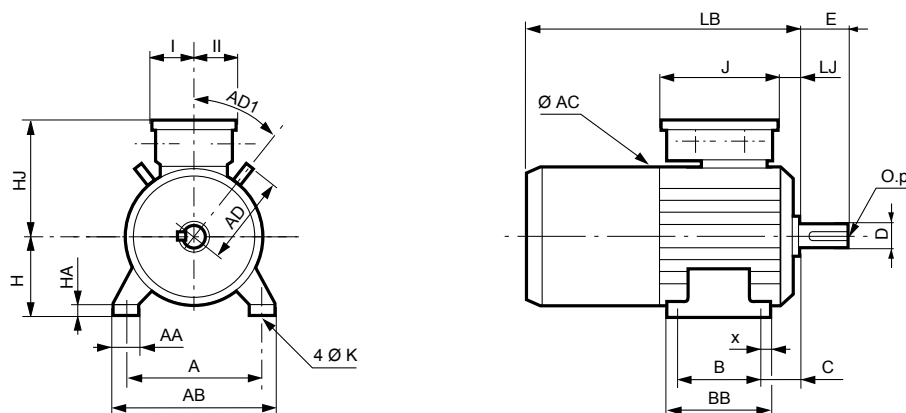

Motor type	Brake type	Main dimensions																	Weight ² kg		
		A	AA	AB	AC ¹	AD	AD1	B	BB	C	H	HA	HJ	J	I	II	K	LB		LJ	x
FLSES 80 L	FFB1	125	32	157	170	-	-	100	130	50	80	10	151	187	63.5	63.5	10	312	13.5	13	19.2
FLSES 80 LG	FFB1	125	32	157	185	-	-	100	130	52	80	10	161	187	63.5	63.5	10	389	13.5	13	25
FLSES 90 SL	FFB1, 2	140	26	170	185	135	40	125	162	56	90	10	173	187	63.5	63.5	10	389	13.5	29	30.8
FLSES 90 LU	FFB2	140	26	170	185	-	-	125	162	56	90	10	173	187	63.5	63.5	10	389	13.5	27.5	34.4
FLSES 100 L	FFB2	160	40	196	204	270	40	140	185	63	100	13	178	187	63.5	63.5	12	437	14.5	29	41.4
FLSES 100 LR	FFB2	160	40	196	204	270	40	140	185	63	100	13	178	187	63.5	63.5	12	437	14.5	29	42.6
FLSES 100 LG	FFB2, 3	160	49	196	235	-	-	140	170	63	100	13	193	187	63.5	63.5	12	448	22.5	11	48.8
FLSES 112 MG	FFB2	190	48	230	235	148	40	140	174	70	112	12	193	187	63.5	63.5	12	448	22.5	32	51
FLSES 112 MU	FFB3	190	48	230	235	148	40	140	174	70	112	12	193	187	63.5	63.5	12	448	22.5	32	55.5
FLSES 132 SM	FFB4	216	63	255	265	165	37.5	178	240	89	132	16	211	187	63.5	63.5	12	596	27.5	48	85.4
FLSES 132 M	FFB4	216	63	255	270	165	37.5	178	240	89	132	16	211	187	63.5	63.5	12	596	27.5	48	92.7
FLSES 132 MR	FFB4	216	63	255	270	165	37.5	178	240	89	132	16	211	187	63.5	63.5	12	596	27.5	48	104
FLSES 160 M	FFB4, 5	254	65	294	315	-	-	210	294	108	160	20	276	246	126	148	14.5	682	30	20	132
FLSES 160 MU	FFB5	254	65	294	315	178	45	210	294	108	160	20	276	246	126	148	14	677	30	20	134
FLSES 160 LUR	FFB5	254	65	294	315	178	45	254	294	108	160	20	276	246	126	148	14	682	30	20	157

1. Housing diameter without lifting rings
2. These values are given for information only

Motor type	Output shaft details										
	D	E	F	G	GD	L	LO	rs	ts	ts1	M.OxP
FLSES 80	19j6	40	6	15.5	6	30	6	0.5	2	20	M6x16
FLSES 90	24j6	50	8	20	7	40	6	0.5	2	20	M8x19
FLSES 100	28j6	60	8	24	7	50	6	0.5	2	20	M10x22
FLSES 112	28j6	60	8	24	7	50	6	0.5	2	20	M10x22
FLSES 132	38k6	80	10	33	8	63	10	0.5	2	20	M12x28
FLSES 160	42k6	110	12	37	8	100	6	0.8	1	45	M16x36

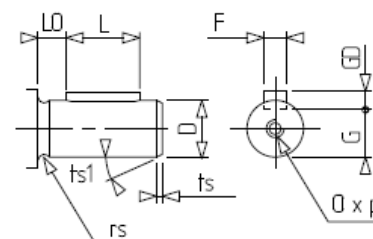

FFB BRAKE MOTORS - IP55 CAST IRON

IMfinity® LS FFB - LSES FFB - FLSES FFB brake motors

IP 55 Cast iron housing

FLSES FFB dimensions

Flange mounted (FF) IM B5 (IM 3001)

Dimensions in millimeters

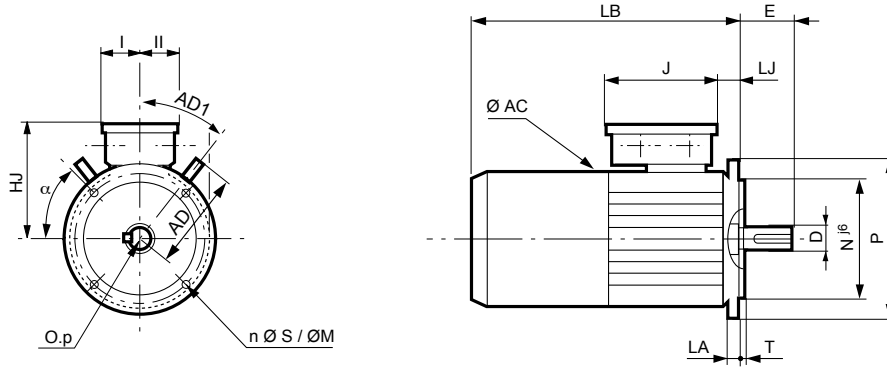

Motor type	Brake type	Main dimensions								
		AC ¹	AD	AD1	HJ	J	I	II	LB	LJ
FLSES 80 L	FFB1	170	-	-	151	187	63.5	63.5	312	13.5
FLSES 80 LG	FFB1	185	-	-	161	187	63.5	63.5	409	34.5
FLSES 90 SL	FFB1, 2	185	135	40	173	187	63.5	63.5	409	33.5
FLSES 90 LU	FFB2	185	-	-	173	187	63.5	63.5	409	33.5
FLSES 100 L	FFB2	204	270	40	178	187	63.5	63.5	437	14.5
FLSES 100 LR	FFB2	204	270	40	178	187	63.5	63.5	437	14.5
FLSES 100 LG	FFB2, 3	235	-	-	193	187	63.5	63.5	423	22.5
FLSES 112 MG	FFB2	235	148	40	193	187	63.5	63.5	448	22.5
FLSES 112 MU	FFB3	235	148	40	193	187	63.5	63.5	448	22.5
FLSES 132 SM	FFB4	265	165	37.5	211	187	63.5	63.5	596	27.5
FLSES 132 M	FFB4	270	165	37.5	211	187	63.5	63.5	596	27.5
FLSES 132 MR	FFB4	270	165	37.5	211	187	63.5	63.5	596	27.5
FLSES 160 M	FFB4, 5	315	-	-	276	246	126	148	682	30
FLSES 160 MU	FFB5	315	178	45	276	246	126	148	677	30
FLSES 160 LUR	FFB5	315	178	45	276	246	126	148	682	30

IEC symbol	Flange (FF) output dimensions								Weight ² kg
	M	N	P	n	α°	S	T	LA	
FF165	165	130	200	4	45	12	3.5	10	19.2
FF165	165	130	200	4	45	12	3.5	10	25
FF165	165	130	200	4	45	12	3.5	10	30.8
FF165	165	130	200	4	45	12	3.5	10	34.4
FF215	215	180	250	4	45	14.5	4	12	41.4
FF215	215	180	250	4	45	15	4	12	42.6
FF215	215	180	250	4	45	15	4	13	48.8
FF215	215	180	250	4	45	15	4	13	51
FF215	215	180	250	4	45	15	4	14	55.5
FF265	265	230	300	4	45	15	4	14	85.4
FF265	265	230	300	4	45	15	4	14	92.7
FF265	265	230	300	4	45	15	4	14	104
FF300	300	250	350	4	45	18.5	5	14	132
FF300	300	250	350	4	45	18.5	5	14	134
FF300	300	250	350	4	45	18.5	5	14	157

- Housing diameter without lifting rings
- These values are given for information only

Motor type	Output shaft details										
	D	E	F	G	GD	L	LO	rs	ts	ts1	M.OxP
FLSES 80	19j6	40	6	15.5	6	30	6	0.5	2	20	M6x16
FLSES 90	24j6	50	8	20	7	40	6	0.5	2	20	M8x19
FLSES 100	28j6	60	8	24	7	50	6	0.5	2	20	M10x22
FLSES 112	28j6	60	8	24	7	50	6	0.5	2	20	M10x22
FLSES 132	38k6	80	10	33	8	63	10	0.5	2	20	M12x28
FLSES 160	42k6	110	12	37	8	100	6	0.8	1	45	M16x36

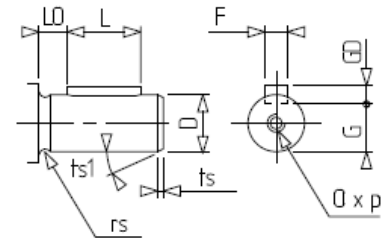

FFB BRAKE MOTORS - IP55 CAST IRON

IMfinity® LS FFB - LSES FFB - FLSES FFB brake motors

IP 55 Cast iron housing

FLSES FFB dimensions

Face mounted (FT) IM B14 (IM 3601)

Dimensions in millimeters

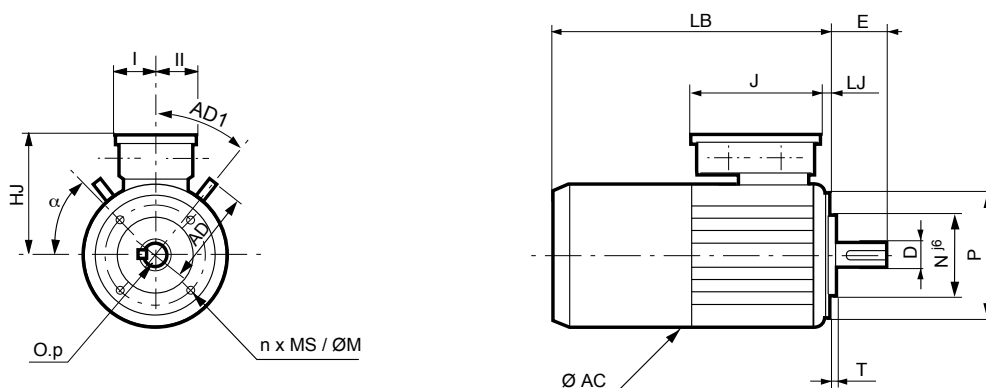

Motor type	Brake type	Main dimensions								
		AC ¹	AD	AD1	HJ	J	I	II	LB	LJ
FLSES 80 L	FFB1	170	-	-	151	187	63.5	63.5	312	13.5
FLSES 80 LG	FFB1	185	-	-	161	187	63.5	63.5	389	13.5
FLSES 90 SL	FFB1, 2	185	135	40	173	187	63.5	63.5	389	13.5
FLSES 90 LU	FFB2	185	-	-	173	187	63.5	63.5	389	13.5
FLSES 100 L	FFB2	204	270	40	178	187	63.5	63.5	437	14.5
FLSES 100 LR	FFB2	204	270	40	178	187	63.5	63.5	437	14.5
FLSES 100 LG	FFB2, 3	235	-	-	193	187	63.5	63.5	448	22.5
FLSES 112 MG	FFB2	235	148	40	193	187	63.5	63.5	448	22.5
FLSES 112 MU	FFB3	235	148	40	193	187	63.5	63.5	448	22.5
FLSES 132 SM	FFB4	270	165	37.5	211	187	63.5	63.5	596	27.5
FLSES 132 M	FFB4	270	165	37.5	211	187	63.5	63.5	596	27.5
FLSES 132 MR	FFB4	270	165	37.5	211	187	63.5	63.5	596	27.5

- Housing diameter without lifting rings
- These values are given for information only

IEC symbol	Faceplate (FT) output dimensions							Weight ² kg
	M	N	P	n	α°	MS	T	
FT100	100	80	120	4	45	M6	3	19.2
FT100	100	80	120	4	45	M6	3	25
FT115	115	95	140	4	45	M8	3	30.8
FT115	115	95	140	4	45	M8	3	34.4
FT130	130	110	160	4	45	M8	3.5	41.4
FT130	130	110	160	4	45	M8	3.5	42.6
FT130	130	110	160	4	45	M8	3.5	48.8
FT130	130	110	160	4	45	M8	3.5	51
FT130	130	110	160	4	45	M8	3.5	55.5
FT165	165	130	200	4	45	M10	3.5	85.4
FT165	165	130	200	4	45	M10	3.5	92.7
FT165	165	130	200	4	45	M10	3.5	104

Motor type	Output shaft details										
	D	E	F	G	GD	L	LO	rs	ts	ts1	M.OxP
FLSES 80	19j6	40	6	15.5	6	30	6	0.5	2	20	M6x16
FLSES 90	24j6	50	8	20	7	40	6	0.5	2	20	M8x19
FLSES 100	28j6	60	8	24	7	50	6	0.5	2	20	M10x22
FLSES 112	28j6	60	8	24	7	50	6	0.5	2	20	M10x22
FLSES 132	38k6	80	10	33	8	63	10	0.5	2	20	M12x28

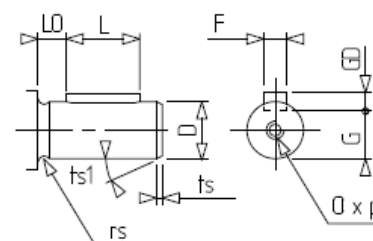

FFB BRAKE MOTORS - IP55 CAST IRON

Equipment and options

List and compatibility of options

	Non-std flange	DLRA	DLM	DMD	'CS' 2nd shaft end	Optional Mf	Indicator release	Indicator wear	Cable gland	TRR	Drip cover	Drain holes	FV	Separate power supply	Absolute encoder	Incremental encoder	Sensors ¹
Non-std flange	•	•	•	•	•	•	•	•	•	•	•	•	•	•	•	•	•
Auto-return hand brake release (DLRA)		•	-	-	•	•	•	•	•	•	•	•	•	•	•	•	•
Release lock off system (DLM)			•	-	•	•	•	•	•	•	•	•	•	•	•	•	•
Remote lock off system (DMD)				•	•	•	•	•	•	•	•	•	•	•	•	•	•
'Crankshaft socket' 2nd shaft end					•	•	•	•	•	•	-	•	-	•	-	-	•
Optional braking torque						•	•	•	•	•	•	•	•	•	•	•	•
Release indicator (RD)							•	•	•	•	•	•	•	•	•	•	•
Wear indicator (WI)								•	•	•	•	•	•	•	•	•	•
Cable gland									•	•	•	•	•	•	•	•	•
Reduce response time (TRR)										•	•	•	•	-	-	-	•
Drip cover (DC)											•	•	-	•	•	•	•
Drain holes												•	•	•	•	•	•
Axial forced ventilation													•	•	•	•	•
Separate brake power supply: 180 VDC coil 400 VAC supply														•	•	•	•
Adaptation and AE series absolute encoder															•	-	•
Adaptation and IE series incremental encoder																•	•
PTO - PTC protection devices ¹ , PT100 - KTY thermal sensors																	•

¹ PTC: as standard for frame size ≥ 160
See § Cable gland for electrical options

•	Compatibility
-	Not available

Equipment and options Mechanical options

OPTIONAL FLANGES FOR LS(ES) SERIES

Motor type	Flange mounted (FF) motors (IM B5)								
	FF 85x70x105	FF 100x80x120	FF 115x95x140	FF 130x110x160	FF 165x130x200	FF 215x180x250	FF 265x230x300	FF 300x250x350	FF 350x300x400
LS 71		■	■	●	◆				
LS(ES) 80 L	■	■	■	■	●	◆			
LS(ES) 80 LG / 90	◆	◆	◆	◆	●	◆	■		
LS(ES) 100 L/LR	■	■	■	■	■	●	■		
LS(ES) 100 LG				■	■	●	◆		
LS(ES) 112 M/MR	■	■	■	■	■	●	■		
LS(ES) 112 MG/MU				■	■	●	◆		
LS(ES) 132 S					■	◆	●		
LS(ES) 132 SM/M/MU					■	■	●	◆	
LS(ES) 160 LR/MP						◆	■	●	
LS(ES) 160 M/L/MU							◆	●	◆
LS(ES) 180 MT/MR							◆	●	◆

● Standard ■ Modified bearing location ◆ Adaptable without shaft modifications

Motor type	Face mounted (FT) motors (IM B14)							
	FT 65x50x80	FT 75x60x90	FT 85x70x105	FT 100x80x120	FT 115x95x140	FT 130x110x160	FT 165x130x200	FT 215x180x250
LS 71	◆	◆	●	◆	◆	◆		
LS(ES) 80 L	◆	◆	◆	●	◆	◆	◆	
LS(ES) 80 LG			◆	●	◆	◆	◆	■
LS(ES) 90			◆	◆	●	◆	◆	■
LS(ES) 100 L/LR			◆	◆	◆	●	◆	◆
LS(ES) 100 LG					◆	●	◆	◆
LS(ES) 112 M/MR			◆	◆	◆	●	◆	◆
LS(ES) 112 MG/MU					◆	●	◆	◆
LS(ES) 132 S/SU						◆	●	◆
LS(ES) 132 SM/M/MU						■	●	■
LS(ES) 160 MP, MR							●	●

● Standard ■ Modified bearing location ◆ Adaptable without shaft modifications

OPTIONAL FLANGES FOR FLSES SERIES

Motor type	Flange mounted (FF) motors (IM B5)						
	FF 115x95x140	FF 130x110x160	FF 165x130x200	FF 215x180x250	FF 265x230x300	FF 300x250x350	FF 350x300x400
FLSES 80 L/LG	■	■	●	◆			
FLSES 90 SL/LU	◆	◆	●	◆			
FLSES 100 L/LR/LG	■	■	■	●			
FLSES 112 MG	■		■	●			
FLSES 112 MU		■	■	●	◆		
FLSES 132 SM/M/MR/MU			■	◆	●		
FLSES 160 M/LUR/MU				◆	◆	●	◆

● Standard ■ Modified bearing location ◆ Adaptable without shaft modifications

Motor type	Face mounted (FT) motors (IM B14)						
	FT 85x70x105	FT 100x80x120	FT 115x95x140	FT 130x110x160	FT 165x130x200	FT 215x180x250	FT 265x230x300
FLSES 80 L/LG	◆	●	◆	◆	◆		
FLSES 90 SL/LU		◆	●	◆	■		
FLSES 100 L/LR/LG			◆	●	◆	◆	
FLSES 112 MG/MU			◆	●	◆	◆	
FLSES 132 SM/M/MR/MU					●	◆	◆

● Standard ■ Modified bearing location ◆ Adaptable without shaft modifications

Equipment and options Mechanical options

RELEASE SYSTEMS



FFB brake motors can be equipped with a manual or electrical brake release system for carrying out maintenance operations such as adjustment and/or manual operation of the system being driven.



Auto-return hand brake release (DLRA)
Whenever the brake has been released, make sure that it is engaged once any maintenance operations have been completed, control rod removed (compliance with EN13135).

As standard, the DLRA lever faces upwards like the terminal box (A).
Exception: Terminal box D, 80 and 112 excluded.

Options:

housing with feet

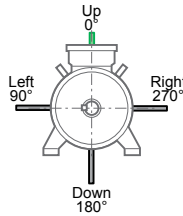

round housing

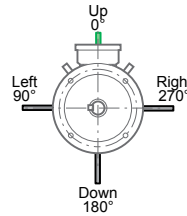

DLM-DMD lever operating positions (Rear view motor)

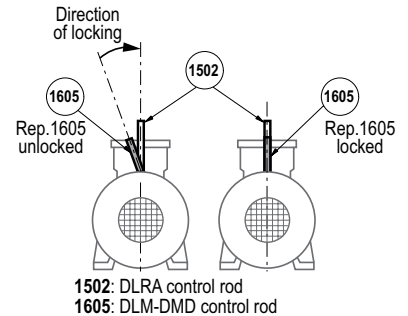

Lock off release system (DLM)
The DLM lever is added to the DLRA lever which it follows in its operating position.



Remote lock off release system DMD
The DMD lever is added to the auto-return hand brake release (DLRA) which it follows in its operation position.

Release	DLRA	DLM	DMD
Release action	Pull the lever towards the non-drive end (NDE)	Pull the lever rod (the one nearest the terminal box) towards the non-drive end (NDE), then swivel the DLM rod to lock	Electrical release: supply the brake coil with power separately from the motor
Keeping the brake released	Requires deliberate action	Permanently without external action	Supply the electromagnet on the lock control board with power. Once the locking contactor is energized, switch off the brake coil power supply and then that of the control board
Return to engaged position	Automatic once traction is eliminated	Automatic when the power is restored or via manual action	Automatic when the power is restored
Areas of use	Safety option: - practical for frequent releases - a safety measure because the brake cannot be left released by mistake.	Safety option: - quick release - saves time when returning to engaged position - a safety measure because it is a way of avoiding leaving the brake in released position.	Safety option: - release and maintaining release remotely - setting a crane movement to weathervane mode

Compatibility with Forced Ventilation (FV) option:

As standard, DLRA lever is oriented to the left, with the standard terminal box position A.

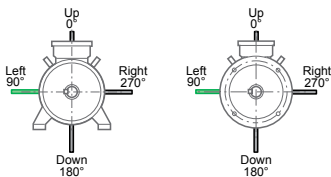

Compatibility with integrated variable speed (ID300) option:

As standard, DLRA lever is oriented to the left, with drive box position A.

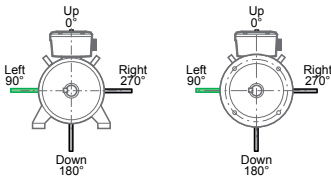

Lever direction	Brake motor							
	with feet (B3)				with flange (B5 - B14)			
	Terminal box A	Terminal box B	Terminal box C	Terminal box D ¹	Terminal box A	Terminal box B	Terminal box C	Terminal box D
Up - 0°	Std	•	X	•	Std	•	•	•
Left - 90°	•	•	X	•	•	•	•	•
Down - 180°	•	•	X	•	•	•	•	•
Right - 270°	•	•	X	•	•	•	•	•
Brake motor + FV (FV terminal box always in position A)								
Up - 0°	-	-	X	-	-	-	-	-
Left - 90°	Std	•	X	•	•	•	•	•
Down - 180°	-	-	X	-	-	-	-	-
Right - 270°	•	-	X	•	•	•	•	•
Brake motor + Integrated variable speed (ID300)								
Up - 0°	-	•	X	•	-	-	-	•
Left - 90°	Std	-	X	-	Std	-	•	-
Down - 180°	-	-	X	-	-	•	-	•
Right - 270°	•	-	X	-	•	-	•	-

1. 80 and 112 excluded

•	Compatibility
-	Impossibility
X	Unallowed assembly

Equipment and options Release systems

LS(ES) FFB series dimensions

Dimensions in millimeters

Frame size	DLRA				DLM - DMD ¹						
	AC	LC	∅LD	LH	AC	LC	∅LD	LH	LE	∅JD	JH
LS71	138	78	6	151	138	78	6	151	42	6	<LH
LS(ES) 80 L	158	82	6	151	158	82	6	151	46	6	<LH
LS(ES) 80 LG, 90 SL	184	131	6	151	184	131	6	151	96	6	<LH
LS(ES) 90 L	184	122	8	176	184	122	8	176	80	8	<LH
LS(ES) 90 LU	184	95	8	176	184	95	8	176	52	8	<LH
LS(ES) 100 LR, 112 MR	184	109	8	176	184	109	8	176	66	8	<LH
LS(ES) 100 LG	235	92	8	176	235	92	8	176	50	8	<LH
LS(ES) 112 MG	235	116	8	176	235	116	8	176	75	8	<LH
LS(ES) 100 L, 112 M	184	122	8	176	184	122	8	176	80	8	<LH
LS(ES) 112 MU	235	94	8	176	235	94	8	176	52	8	<LH
LS(ES) 132 S	220	116	8	176	220	116	8	176	75	8	<LH
LS(ES) 132 MU	265	157	13	307	265	157	13	307	99	13	<LH
LS(ES) 132 SM, M	265	181	13	307	265	181	13	307	123	13	<LH
LS(ES) 160 LR, MR	265	144	13	307	265	144	13	307	86	13	<LH
LS(ES) 160 MP	265	175	13	307	265	175	13	307	117	13	<LH
LS(ES) 160 M, L	309	162	13	307	309	162	13	307	106	13	<LH
LSES 160 MU, LU	309	142	13	307	309	142	13	307	86	13	<LH
LS(ES) 180 MT, LT	309	162	13	307	309	162	13	307	106	13	<LH
LS(ES) 180 MR, LR	309	142	13	307	309	142	13	307	86	13	<LH

1. DMD on FFB2 to FFB5

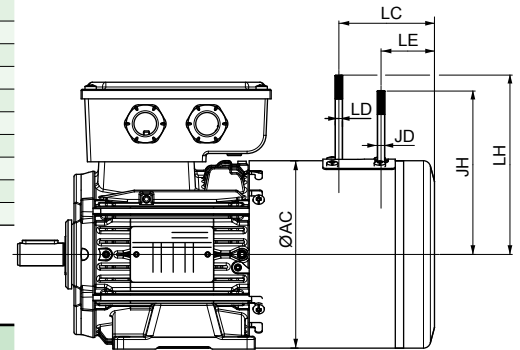

FLSES FFB series dimensions

Frame size	DLRA				DLM - DMD ¹						
	AC	LC	∅LD	LH	AC	LC	∅LD	LH	LE	∅JD	JH
FLSES 80 L	158	82	6	151	158	82	6	151	46	6	<LH
FLSES 80 LG	185	131	6	151	185	131	6	151	96	6	<LH
FLSES 90 SL	185	122	8	176	185	122	8	176	80	8	<LH
FLSES 90 LU	185	95	8	176	185	95	8	176	52	8	<LH
FLSES 100 L	204	122	8	176	204	122	8	176	80	8	<LH
FLSES 100 LR	204	109	8	176	204	109	8	176	66	8	<LH
FLSES 100 LG	235	116	8	176	235	116	8	176	75	8	<LH
FLSES 112 MG	235	116	8	176	235	116	8	176	75	8	<LH
FLSES 112 MU	235	94	8	176	235	94	8	176	52	8	<LH
FLSES 132 SM, M	265	181	13	307	265	181	13	307	123	13	<LH
FLSES 132 MR	265	132	13	307	265	132	13	307	74	13	<LH
FLSES 160 MU	309	142	13	307	309	142	13	307	86	13	<LH
FLSES 160 LUR	309	142	13	307	309	142	13	307	86	13	<LH

1. DMD on FFB2 to FFB5

Non Drive End shaft

Frame size	Output shaft (NDE) (crankshaft socket)			
	DA	EC	GB	GF
LS71	15	9	8	11
LS(ES) 80 L	15	11	8	11
LS(ES) 80 LG	15	12	8	11
LS(ES) 90 SL, L, LU	20	15	11	13
LS(ES) 100 L, LR	20	15	11	13
LS(ES) 112 M, MR	20	15	11	13
LS(ES) 100 LG	25	17	11	17
LS(ES) 112 MG, MU	25	15	11	17
LS(ES) 132 S	25	15	11	17
LS(ES) 132 M, MU, MR	28	22	18	20
LS(ES) 160 MP, LR	28	22	18	20

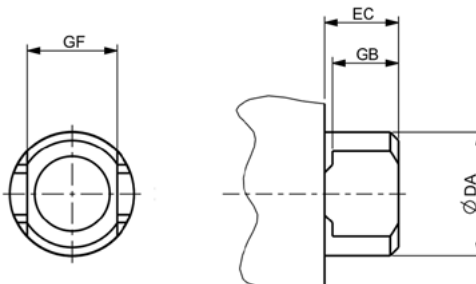

Equipment and options Mechanical options

OPTIONAL BRAKING TORQUE

If the application does not need the braking torque offered as standard on the brake motor (Characteristics Tables

section), as an option, the brake has different torques as shown in the table below.

Braking torques (N.m) given for information only; for standards-related restriction, please consult Nidec Leroy-Somer.

No. of springs	FFB1 ¹		FFB2		FFB3		FFB4		FFB5	
	Color	M _f (N.m)	Color	M _f (N.m)	Color	M _f (N.m)	Color	M _f (N.m)	Color	M _f (N.m)
3		4.5		11	-	-		41	-	-
4		6		15	-	-		55	-	-
5	Purple (RAL 4008)	7.5	White (RAL 1013)	19	Orange (RAL 2000)	37	Brown (RAL 8017)	69	Black (RAL 9005)	-
6		9		23		45		83		
7		10.5		26		52		96		120
8		12		30		59		110		140
9	-	-	-	-		67		-		160
10	-	-	-	-		-		-		180
										200

1. M_f: 7.5 N.m maximum for frame size 71

INDICATOR MICROCONTACT (RELEASE/APPLICATION, WEAR)

As an option, the whole range of FFB brake motors can be equipped with a system to monitor the brake condition (release or application) and/or how worn the lining is. They are mounted and adjusted in the factory.

The microcontact wiring is connected in the terminal box on dominos (details in the table).

Indicators	Release indicator (Open/Close)	Wear indicator
Current	6A	6A
Voltage	250V	250V
Mounting	on dominos (3 wires blue/black/gray) Black/Blue = NO Black/Gray = NC	on dominos (3 wires blue/black/gray) Black/Blue = NO Black/Gray = NC

NO: normally open; NC: normally closed

RELEASE/APPLICATION INDICATOR



For brakes fitted with a release indicator, while the brake is supplied with power the armature actuates a microswitch (discrete) fixed on the yoke indicating brake release.

When the power is switched off, the microswitch changes state in order to confirm that the brake is engaged.

WEAR INDICATOR

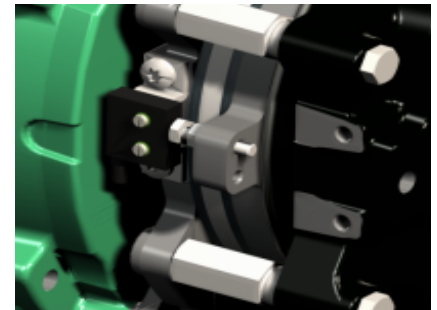

For brakes fitted with a wear indicator, if the brake lining is worn (+ 0.6mm) the armature actuates the microswitch (discrete) fixed on the backplate and informs the user of the need to adjust the air gap or change the brake lining if it is less than the required minimum.

DRIP COVER

For brake motors operating outdoors, with the drive shaft downwards (IM1011 V5, IM3001 V1, IM3611 V18), an optional drip cover is recommended. This is an option and should be specified on the order if required.

Type	Drip cover	
	a	b
LS(ES) 71	138	25
(F)LS(ES) 80	184	25
(F)LS(ES) 90	220	25
(F)LS(ES) 100	220	25
LS(ES) 112 M, MR	220	25
(F)LS(ES) 112 MG, MU	264	25
LS(ES) 132 S, SU	264	25
(F)LS(ES) 132 M, MU, SM, MR	310	25
(F)LS(ES) 160	310	25
LS(ES) 180	310	25

Dimensions in millimeters

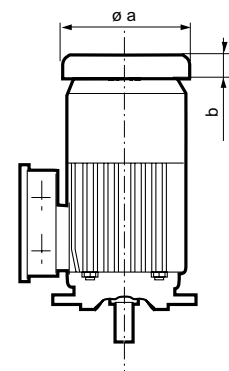

Equipment and options

Electrical options

SENSORS

Motors are protected by a manual or automatic overcurrent relay, placed between the isolating switch and the motor. This relay can in turn be protected by fuses. These protection devices provide total protection of the motor against non-transient overloads.

If a shorter reaction time is required, if you want to detect transient overloads, or if you wish to monitor temperature rises at "hot spots" in the motor or at strategic points in the installation for maintenance purposes, it is advisable to install heat sensors at sensitive points. The various types are shown in the table below, with a description of each.

We offer PTO, PTC, PT100 and PT1000 heat sensors. It must be emphasized that under no circumstances can these sensors be used to carry out direct regulation of the brake motor operating cycles.

Built-in indirect thermal protection

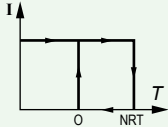
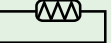
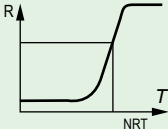
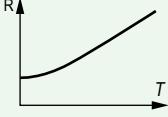
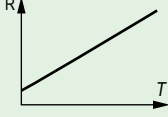
Type	Operating principle	Operating curve	Braking capacity (A)	Protection provided	Mounting Number of devices*
Normally closed thermal protection PTO	Bimetallic strip, indirectly heated, with normally closed (NC) contact 		2.5 A at 250 V with $\cos \varphi 0.4$	general surveillance for non-transient overloads	Mounted in control circuit 2 in series
Positive temperature coefficient thermistor PTC	Non-linear variable resistor, indirectly heated 		0	general surveillance for transient overloads	Mounted with associated relay in control circuit 3 in series
Temperature sensor PT 1000	Resistance depends on the winding temperature		0	high accuracy continuous surveillance of key hot spots	Mounted in control boards with associated reading equipment (or recorder) 1 per hot spot
Platinum resistance thermometer PT 100	Linear variable resistor, indirectly heated		0	high accuracy continuous surveillance of key hot spots	Mounted in control boards with associated reading equipment (or recorder) 1 per hot spot

- NRT: nominal running temperature

- The NRTs are chosen according to the position of the sensor in the motor and the temperature rise class

- PTC: as standard on frame size ≥ 160

* The number of devices relates to the winding protection.

Fitting thermal protection

- PTO (or PTF), in the control circuits.
- PTC, with relay, in the control circuits.
- PT 100 or PT 1000, with reading equipment or recorder, in the installation control panel for continuous surveillance.

Alarm and early warning

All protective equipment can be backed up by another type of protection (with different NRTs). The first device will then act as an early warning (light or sound signals given without shutting down the power circuits), and the second device will be an alarm (which shuts down the power circuits).

Built-in direct thermal protection

For low rated currents, bimetallic strip-type protection can be used. The line current passes through the strip, which shuts down or restores the supply circuit as necessary. The design of this type of protection allows for manual or automatic reset.

Equipment and options Electrical options

CABLE GLAND

The standard terminal box of the FFB brake motor has holes on sides 1 and 3 (Frame sizes 71 to 132 S, SU: 4 x ISO M20x1.5; Frame sizes 132 SM, M, MU to 160 LR, MP, MR: 2 x ISO M25x1.5 and HA 160 L, LUR, M, MUR to 180 : 2xISO32 + 2xISO20 (6 holes with accessories). These holes are closed with threaded plugs. An optional cable gland kit is available, otherwise procure the necessary cable glands in accordance with the table opposite.

Cable size and tightening of cable glands (Norme EN 50262)

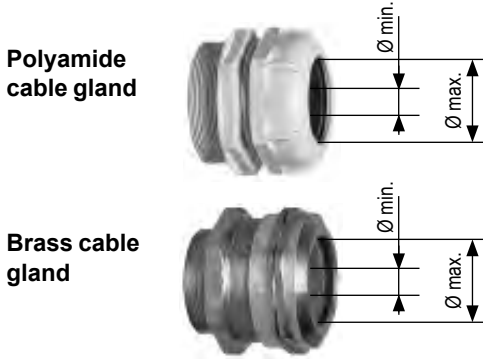

LS, LSES FFB series for 400V std supply voltage

Brake motor type	Cable gland type	Standard cable gland (polyamide)		
		Cable size		Tightening Gland and body (N.m)
		Ø min. cable (mm)	Ø max. cable (mm)	
LS 71 ; accessories ¹	ISO 20a	5	12	2
LS, LSES 80 to 132 S, SU	ISO 20	7	14	2
LS, LSES 132 M to 180	ISO 25	9	18	3
LS, LSES 160 L, M, MU to 180	ISO 32	14	25	5

FLSES FFB series for 400V std supply voltage

Brake motor type	Cable gland type	Brass anchoring cable gland		
		Cable size		Tightening Gland and body (N.m)
		Ø min. cable (mm)	Ø max. cable (mm)	
Accessories ¹	ISO 20a	6	10	4
FLSES 80 to 112 MU	ISO 20	8	12	4
FLSES 132	ISO 25	11.5	18	6
FLSES 160	ISO 32	16	22	10

1. Sensors (PTO, ...), resistors ≤ 5 ; for above, provide stranded wires

FORCED VENTILATION

The forced ventilation option is used to:

- operate at zero speed continuously with a torque the same as the motor rated torque at 50 Hz.
- operate in overspeed mode:
 - n > 2600 rpm with 4- and 6-pole
 - n > 4500 rpm with 2-pole
- limit the machine temperature rise for operation with a drive.

Characteristics

Brake motor frame size	Supply voltage ¹	Consumption		Index of protection ²
		P (W)	I (A)	
71	Single-phase 230V	22	0.13	IP54
80	Single-phase 230/400V 50Hz	98	0.43/0.25	IP55
80 to 132	Single-phase 230/400V 50Hz	91	0.40/0.23	IP55
160, 180	Three-phase 230/400V 50Hz	150	0.94/0.55	IP55

1. ±10% for voltage, ±2% for frequency

2. Index of protection of the forced ventilation unit installed on the motor

Dimensions

LS(ES) FFB series dimensions

Frame size	Forced ventilation unit on FFB brake motor ¹		
	HJ-LJ	LB	
		B3-B14	B5
LS 71 M	Same as FFB std	386	386
LS 71 L		396	396
LS(ES) 80 L		427	427
LS(ES) 80 LG		481	501
LS(ES) 90 L, LU, SL		481	501
LS(ES) 100 L, LR		529	529
LS(ES) 100 LG		574	574
LS(ES) 112 M, MR		529	529
LS(ES) 112 MG, MU		574	574
LS(ES) 132 S		615	615
LS(ES) 132 SM, M, MU		711	711
LS(ES) 160 LR, MP, MR		786	786
LS(ES) 160 M, L		840	840
LS(ES) 180 MR, LR		835	835

1. FV without or with encoder

FLSES FFB series dimensions

Dimensions in millimeters

Frame size	Forced ventilation unit on FFB brake motor ¹		
	HJ-LJ	LB	
		B3-B14	B5
FLSES 80 L	Same as FFB std	427	427
FLSES 80 LG		481	501
FLSES 90 SL, LU		481	501
FLSES 100 L, LR		529	529
FLSES 100 LG		574	574
FLSES 112 MU, MG		574	574
FLSES 132 SM, M, MR, MU		711	711
FLSES 160 M, LUR		840	840
FLSES 160 MU		835	835

1. VF without or with encoder

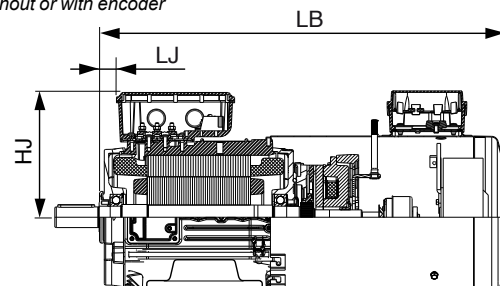

Equipment and options Electrical options

CHOICE OF SPEED FEEDBACK

Encoder characteristics

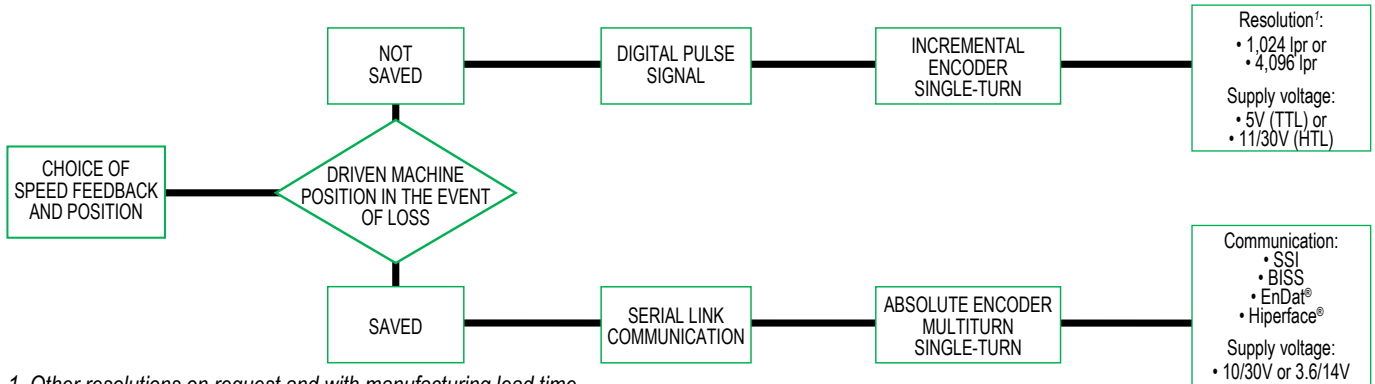

1. Other resolutions on request and with manufacturing lead time

- Incremental encoder:

This generator supplies a number of pulses on channels A, A/, B, B/, 0 marker, 0/ marker proportional to the speed. A 1,024 lpr or 4,096 lpr encoder is sufficient for most applications. However, where stability at very low speed (<10 rpm) is required, use of a higher resolution encoder is recommended. Our Std EC, cURus, Reach is the 5VDC (TTL output) or 11/30VDC (HTL output).

- Multiturn Absolute encoder:

This saves the position in the revolution and also over several revolutions (max. 4,096), if the power source is disconnected. A reference point is no longer necessary. Data is transmitted via different communication protocols (SSI, BiSS, EnDat2.1®, Hiperface®, etc.); some protocols are owned by a particular supplier.

In certain cases, SinCos or incremental data is also available. Our Std EC, cURus, Reach is the SinCos - SSI - Multiturn (Refer to the guide "Speed and position feedback devices" ref.5664).

ENCODER DIMENSIONS

Dimensions in millimeters

LS(ES) FFB series dimensions

Frame size	FFB brake + Encoder		
	HJ-LJ	J	LB
LS 71 M		197	329
LS 71 L		197	339
LS(ES) 80 L		197	355
LS(ES) 80 LG		197	436
LS(ES) 90 L, LU, SL		197	435
LS(ES) 100 L, LR		197	483
LS(ES) 100 LG		197	468
LS(ES) 112 M, MR	Same as	197	483
LS(ES) 112 MG, MU	FFB std	197	493
LS(ES) 132 S, SU		197	534
LS(ES) 132 SM, M, MU		197	596
LS(ES) 132 MR		197	624
LS(ES) 160 MP		197	671
LS(ES) 160 LR, MR		197	699
LS(ES) 160 M, L		216	711
LS(ES) 180 MR, LR		216	706

FLSES FFB series dimensions

Frame size	FFB brake + Encoder		
	HJ-LJ	J	LB
FLSES 80 L		224	355
FLSES 80 LG		224	436
FLSES 90 SL, LU		224	436
FLSES 100 L, LR		224	483
FLSES 100 LG	Same as	224	493
FLSES 112 MU, MG	FFB std	224	493
FLSES 132 SM, M, MU		224	596
FLSES 132 MR		224	624
FLSES 160 M, LUR		252	711
FLSES 160 MU		252	706

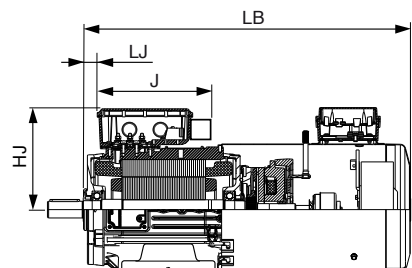

ENCODER + FORCED VENTILATION DIMENSIONS

See page 42: Forced ventilation dimensions

Equipment and options

Electrical options

ENCODERS CONNECTION

- Standard incremental encoder: 5V DC (TTL) or 11/30V (HTL)
1,024 lpr or 4,096 lpr - Separate brake power supply

Terminal No.	Connection	Color
1	0V	White
2	+VDC	Brown
3	A	Green
4	B	Yellow
5	0	Gray
6	<u>A</u>	Pink
7	<u>B</u>	Blue
8	<u>0</u>	Red
9	Ground	
10	Ground	
11	Ground	
12	Ground	

- Standard absolute encoder: 10/30V DC SinCos SSI multiturn
- Separate brake power supply

Terminal No.	Connection	Function
1	0V	Encoder ground
2	+VCC	Supply voltage
3	Clock+	Clock signal
4	Clock-	Clock signal
5	Data+	Data signal
6	Data-	Data signal
7	SET	Current position defined at 0 (reset)
8	DIR	Clockwise or anti-clockwise counting direction
9	A	Sine output (incremental)
10	<u>A</u>	Sine output (incremental)
11	B	Cosine output (incremental)
12	<u>B</u>	Cosine output (incremental)

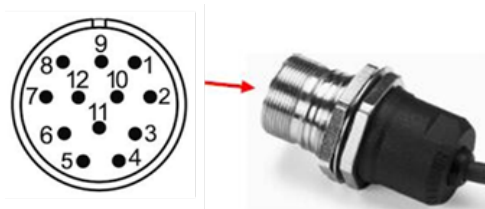

View of M23 male connector base at the encoder end

Identification - Installation Identification

Check that the equipment conforms to the order: mounting arrangement, information on the nameplate.

Information ① to ⑫ should be quoted when ordering spare parts.

Other logos can optionally be provided: agreement prior to ordering is essential.

Example: LSES 100 LG FFB3 IFT/IE3

MOTOR NAMEPLATE

(for FFB brake)

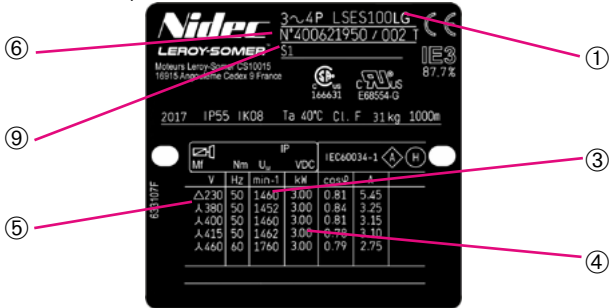

Definition of symbols

T: Impregnation class

IE3: Efficiency class

IP-- IK--: Ingress protection*

Cl.F: Insulation class

(Ta) 40°C: Ambient operating temperature

cos P ou φ: Power factor

A: Rated current

Δ: Delta connection

Λ: Star connection

⊠: Vibration level

Ⓜ: Balancing mode

BRAKE MOTOR NAMEPLATE WITH DRIVE



Bearings

DE: Drive End or Drive End bearing (side F)

NDE: Non Drive End or Non Drive End bearing (side B)

Marking

Definition of symbols used on nameplates

		Motor nameplate	FFB brake nameplate
CE	Legal mark of compliance of equipments with the requirements of European Directives	Frame size 71 to 180	Frame size 71 to 180
cRUUS	Legal mark of compliance of equipments with the USA and Canada markets	Frame size 71* to 180 (E68554-G)	-
CS166631	Legal mark of brake's compliance with the USA and Canada requirements	Frame size 80 to 180	Frame size 71 to 180
71* CS	Legal mark of compliance of equipments with the USA and Canada requirements	*or optional Frame size 71	-

Essential information included on the nameplates:

①	Motor series, frame size
②	FFB brake type <input checked="" type="checkbox"/>
③	Speed of rotation (rpm)
④	Rated power (kW)
⑤	Motor voltage (V)
⑥	Motor and brake manufacturing no.
⑦	Mf: Braking torque (N.m)
⑧	U: Brake coil voltage (VDC)
⑨	Duty - Operating factor
⑩	I: Coil current (mA)
⑪	Special marking (ATEX) <input checked="" type="checkbox"/>
⑫	rpm: Maximum speed use

Please quote when ordering spare parts

Atex zone 22 use

Atex special marking: ⑪

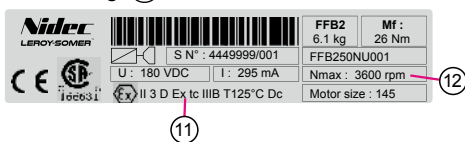

II 3 D Ex tc IIIB: II group, 3 category, non conducting dust

T125°C: maximum surface temperature

Dc: equipment mode of protection

Nmax 3600 rpm: maximum speed of rotation in Atex

The brake must be assembled with a motor which respects the same ATEX level requirement at least.

If the brake is not equipped with a release/application indicator, check the clearance periodically according to the rates and the energy to be dissipated on each braking operation (ref. § Operation-Brake energy capacity).

Identification - Installation Exploded views and parts list

(F)LS(ES) motor and FFB brake: Frame size from 71 to 132 Aluminium or frame size from 80 to 132 Cast iron

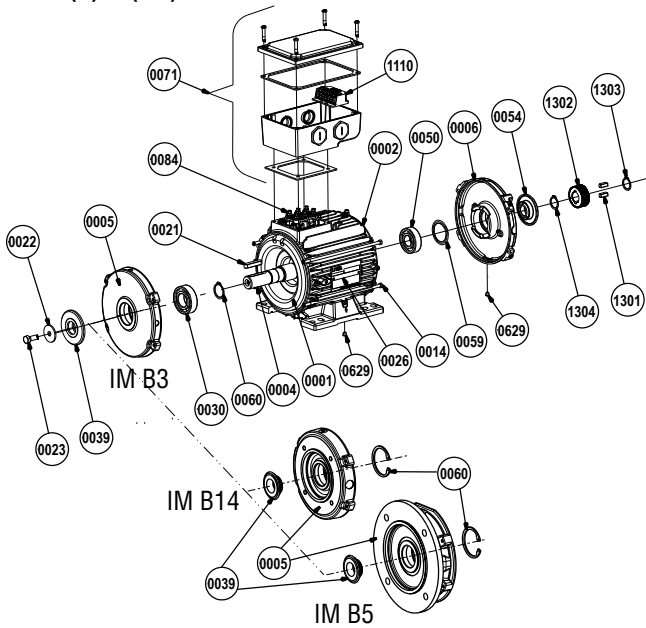

No.	Name	Qty	No.	Name	Qty
1	Wound stator	1	25	Lifting ring (frame size ≥ 100)	2
2	Housing	1	26a	Motor nameplate	1
4	Rotor	1	26b	Brake nameplate	1
5	DE shield	1	27	Fan cover screws (no.13)	4
6	Motor NDE shield	2	30	Drive end bearing (DE)	1
7	Fan	1	39	Drive end weatherproof seal (DE)	1
8	Fan washer (no.7)	0 or 1	50	Bearing on brake side (NDE)	1
9	Locking circlips (no.7)	1 or 2	54	Weatherproof seal on brake side (NDE)	1
13	Fan cover	1	59	Preloading (wavy) washer	1
14	Ties rod	3 or 4	60	Internal circlip (DE no.30)	1
21	Shaft end key (DE)	1	71	Terminal box	1
22	Shaft end washer	1	84	Terminal plate	1
23	Locking screw (no.22)	1	629	Drain hole plug	1 or 2
xx	Primary maintenance part				

FFB brake for (F)LS(ES) motor:
Frame size from 71 to 132 Aluminium or
frame size from 80 to 132 Cast iron

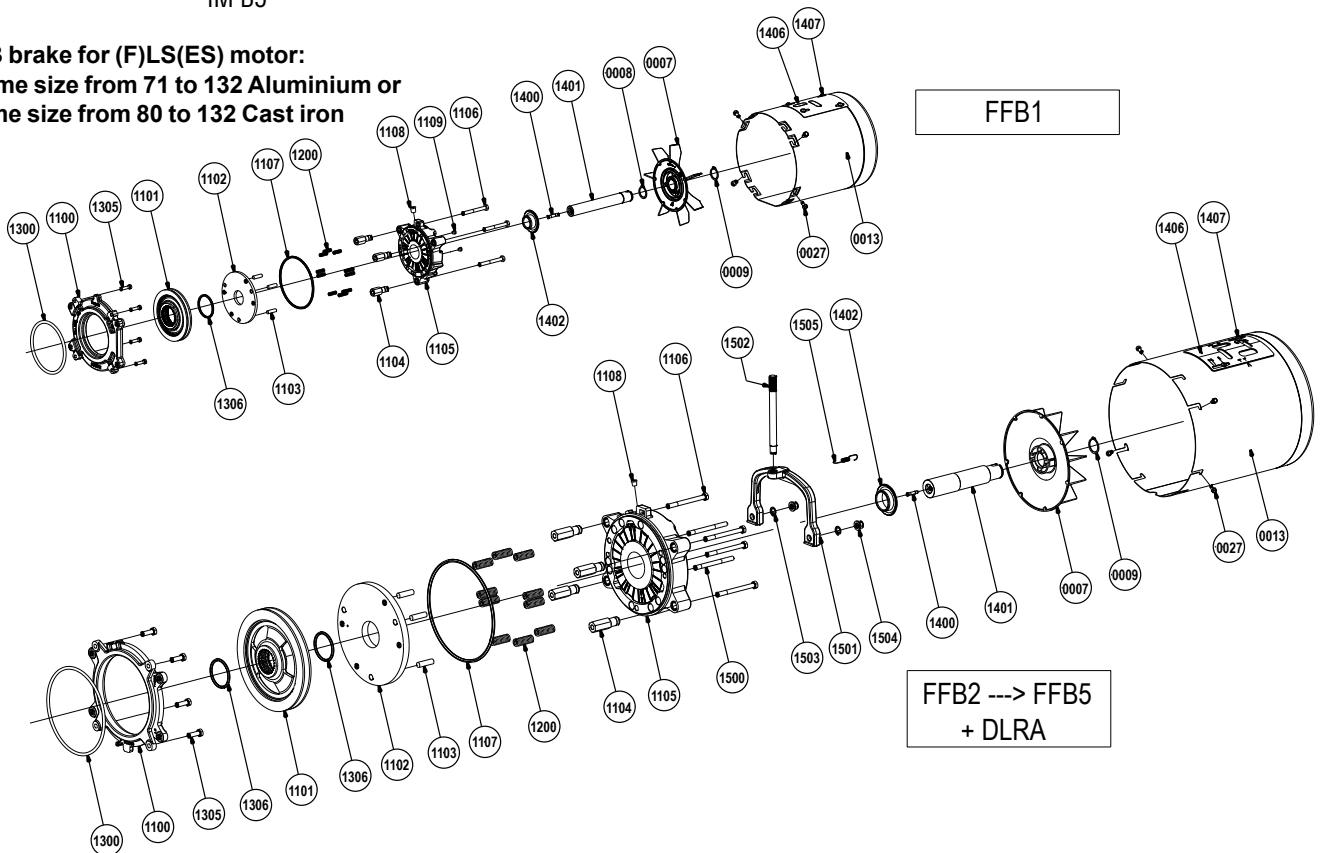

No.	Name	Qty	No.	Name	Qty	No.	Name	Qty
1100	Friction backplate	1	1109	Pin hole blanking plug	2	1306	O ring seal (no.1101)	2
1101	Brake disc	1	1110	Brake power supply unit	1	1400	Extension/shaft linking setscrew (no.1401/4)	1
1102	Armature	1	1200	Compression spring	3 to 10	1401	Extension shaft	1
1103	Pins	3 or 4	1300	O ring seal (between no.6 and no.1100)	1	1402	VLS seal (no.1105)	1
1104	Spacer	3 or 4	1301	Splined ring key (no.1302)	2	1406	Cover closing hatch	1
1105	Yoke	1	1302	Splined ring	1	1407	Fixing screws (no.1406)	4
1106	Fixing screws (no.1105/1100)	3 or 4	1303	Retaining ring (no.1302)	1	1500 to 1505	DLRA option (see section 6.1 Maintenance guide ref.5287)	
1107	O ring seal	1	1304	Washer	0 or 1			
1108	Cable entry (no.1105)	1	1305	Backplate fixing screws (no.1100)	3 or 4			
xx	Primary maintenance part							

Identification - Installation Exploded views and parts list

(F)LS(ES) motor and FFB brake:
Frame size 160 and 180 Aluminium or
frame size 160 Cast iron

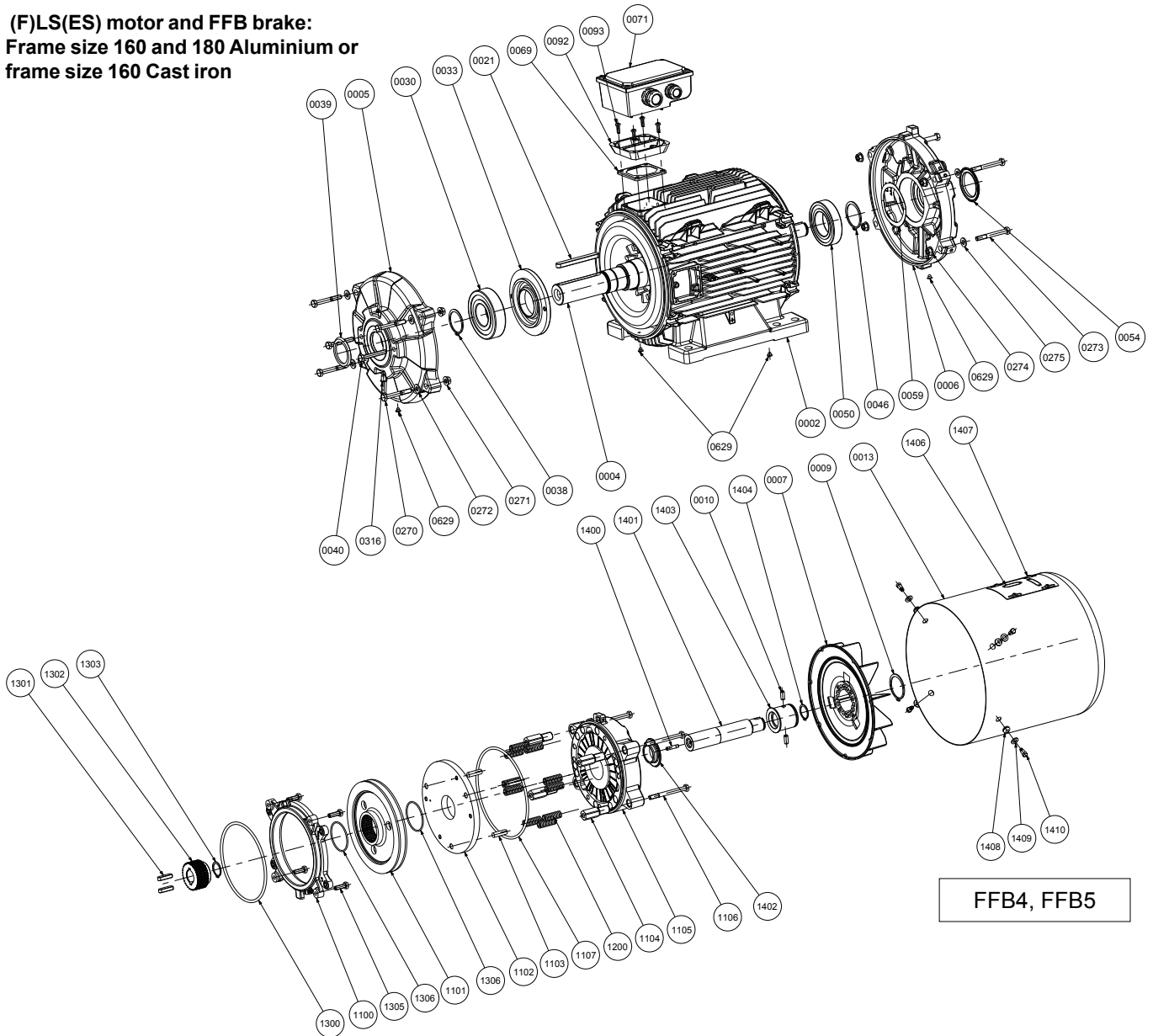

No.	Name	Qty	No.	Name	Qty	No.	Name	Qty
2	Housing	1	71	Terminal box	1	1107	O ring seal	1
4	Rotor	1	92	TB base	1	1200	Compression spring	3 to 10
5	DE shield	1	93	Screw (no. 92)	4	1300	O ring seal (between no. 6 and 1100)	1
6	Motor NDE shield	2	270	Fixing screw (no. 5)	5	1301	Splined ring key (no. 1302)	2
7	Fan	1	271	Fixing nut (no. 270)	5	1302	Splined ring	1
9	Locking circlips (no. 7)	1 or 2	272	Washer under nut (no. 270)	5	1303	Retaining ring (no. 1302)	1
10	Pin (no. 7)	2	273	Fixing screw (no. 6)	4	1305	Backplate fixing screws (no. 1100)	4
13	Fan cover	1	274	Fixing nut (no. 273)	4	1306	O ring seal (no. 1101)	2
21	Shaft end key (DE)	1	275	Washer under nut (no. 273)	4	1400	Extension/shaft linking setscrew (no. 1401/4)	1
30	Drive end bearing (DE)	1	316	Plug	1	1401	Extension shaft	1
33	Bearing cover (no. 30)	1	629	Drain hole plug	3	1402	VLS seal (no. 1105)	1
38	External circlip (no. 30)	1	1100	Friction backplate	1	1403	Fan adapter socket	1
39	Drive end weatherproof seal (DE)	1	1101	Brake disc	1	1404	Fixing screw socket/extension	1
40	Cover fixing screw (no. 33)	1	1102	Armature	1	1406	Cover closing hatch	1
46	External circlip (no. 50)	1	1103	Pins	3	1407	Fixing screws (no. 1406)	4
50	Bearing on brake side (NDE)	1	1104	Spacer	4	1408	Cable entry	4
54	VLS seal (no. 1105)	1	1105	Yoke	1	1409	Washer under nut	4
59	Preloading (wavy) washer	2	1106	Fixing screws (no. 1105/1100)	4	1410	Shoulder bolts	4
69	TB gasket	1						
xx	Primary maintenance part							

Identification - Installation Installation

The following information is given for guidance only, and should never be used as a substitute for the current standards, nor does it relieve the installation company of its responsibility.

Depending on the installation, more optional elements can be added to the installation.

RECEIPT

Check the state of the brake motor; if there is any damage to the motor or even its packaging, contact the carrier.

Check that the brake motor conforms to the order (mounting arrangement, information on the nameplates).

STORAGE

Store the equipment in a clean, dry location, protected from shocks, vibrations, variations in temperature and in an environment with relative humidity of less than 90 %.

Storage for longer than 6 months leads to special conditions, we will be happy to discuss these with you.

After storage for a period of more than 6 months, disconnect the brake power supply unit and check the winding insulation resistance (phase/earth resistance higher than 10 MΩ).

Drain any condensation water.

COMMISSIONING

The brake motor is designed to operate at the speeds indicated on the nameplate (do not exceed the maximum speed stated on the brake nameplate: N_{max}).

Comply with the voltages and frequencies indicated on the nameplate. (Do not deviate by more than 5% from the voltage extremes on the nameplate and by more than 1% from the frequencies.)

For hoisting applications, do not use a motor that is not rated S3 (except for variable speed). Do not use a motor with a different duty type from that on the nameplate no. ⑨ (see Motor nameplate section on page 45).

MECHANICAL INSTALLATION

See manuals ref.5286 (FFB brake motor installation manual) and ref.1889 (Recommendations for storing and commissioning AC motors manual).

If the brake motor has been stored at a temperature lower than -10°C, warm it, unlock the brake and turn the shaft manually before starting up the machine.

If the brake motor is to be used at a temperature lower than -25°C, it must not be fitted with a sensor. It can be fitted with thermocouples.

Ensure there is minimum clearance (corresponding to the length of the cover) at the non-drive end of the brake motor so it can be put down (inspections and brake adjustment).

Install the brake motor in conditions conforming to those on the order (temperature, relative humidity, altitude).

Protect it from oily projections (according to the environmental conditions according to EN 60721-3-4 4K2/4Z1/4Z5/4Z7/4B1/4C2/4S2/4M3).

When the brake motor is fitted with lifting rings, these are for lifting the brake motor on its own.

Mount the brake motor in the position specified on the order, on a flat, rigid base in order to prevent distortion and vibration.

Ensure the fixing screws are tightened to the correct tightening torque in accordance to NF E25-030-1 (class 8.8 minimum according to ISO 898-1), the screw diameter must be the right size for the fixing holes.

Ensure the mechanical shafts are aligned and the transmission mechanism is mounted in accordance with good practice.

Do not knock the motor (terminal box, cover), the shaft or the coupling during mounting, do not crush the seal, do not project beyond the shoulder of the shaft.

Ensure correct brake motor cooling, the air intakes and outlets must be kept clear.

Check that the loads applied to the motor shaft (especially the belt tension) are compatible with the values stated in our technical catalogues.

WIRING

Drive power supply cables

These cables do not necessarily need shielding. Their cross-section is recommended in the drive documentation, however, it can be adapted according to the type of cable, installation method, the cable length (voltage drop), etc. See the Sizing power cables section below.

Motor power supply cables

These cables must be shielded to ensure EMC conformance of the installation. The cable shielding must be connected over 360° at both ends. At the motor end, special EMC cable glands are available as an option. The cable cross-section is recommended in the motor documentation, however, it can be adapted according to the type of cable, installation method, the cable length (voltage drop), etc. See the Sizing power cables section below.

Identification - Installation Installation

Encoder cables

Shielding the sensor cables is important due to the high voltages and currents present at the drive output. This cable must be laid at least 30 cm away from any power cables. See the Encoders section.

Sizing power cables

The drive and motor power supply cables must be sized according to the applicable standard, and according to the design current, stated in the drive documentation.

The different factors to be taken into account are:

- The installation method: in a conduit, a cable tray, suspended, etc.
- The type of conductor: copper or aluminium.

Once the cable cross-section has been determined, check the voltage drop at the motor terminals. A significant voltage drop results in increased current and additional losses in the motor (temperature rise).

A variable speed drive and transformer system that have been grounded in accordance with good practice will contribute significantly to reducing the voltage on the shaft and the motor casing, resulting in fewer high-frequency leakage currents. Premature breakage of bearings and auxiliary equipment such as encoders should also be avoided wherever possible.

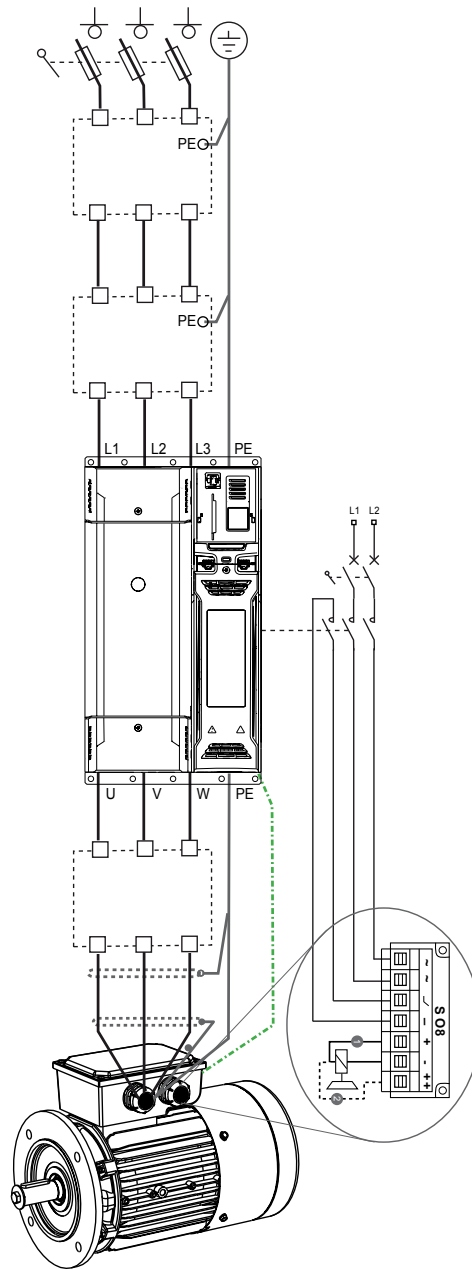

Identification - Installation Packaging weights and dimensions

ROAD TRANSPORT (code 30) or AIR TRANSPORT (code 40)

Cardboard boxes ¹		
Ref.	Tare	Dimensions (L x W x H) ²
	kg	mm
P0 000	0.25	245 x 190 x 150
P0 100	0.35	256 x 222 x 165
P0 200	0.40	330 x 288 x 172
R1	0.25	330 x 145 x 200
R2	0.50	420 x 200 x 240
R3	0.65	520 x 220 x 280
R4	1.05	550 x 320 x 360
R5	0.85	580 x 260 x 280
R6	1.30	780 x 300 x 430
R7	0.75	420 x 300 x 260
R8	0.90	500 x 330 x 290
R5 Marine	0.85	580 x 260 x 280

Open pallet box or Open-slat crate		
Tare	Outer dimensions (L x W x H) ²	Inner dimensions (L x W x H) ²
kg	mm	mm
10	720 x 420 x 550	650 x 350 x 400
26	830 x 520 x 660	760 x 450 x 500
30	990 x 570 x 620	920 x 500 x 550
47	920 x 870 x 700	850 x 800 x 550
48	990 x 870 x 880	920 x 800 x 720
45	1,270 x 870 x 700	1,200 x 800 x 550
47	1,270 x 870 x 880	1,200 x 800 x 720
61	1,270 x 1,070 x 730	1,200 x 1,000 x 550
62	1,270 x 1,070 x 900	1,200 x 1,000 x 720
64	1,270 x 1,070 x 1 050	1,200 x 1,000 x 870

PACKAGING FOR SEA TRANSPORT (code 10)

Plywood crates		
Tare	Outer dimensions (L x W x H) ²	Inner dimensions (L x W x H) ²
kg	mm	mm
20	740 x 480 x 730	680 x 420 x 600
26	840 x 520 x 710	760 x 440 x 530
30	980 x 560 x 720	920 x 500 x 550
58	1,120 x 750 x 850	1,040 x 680 x 670
60	1,100 x 950 x 680	1,020 x 870 x 500
80	1,100 x 950 x 1,180	1,020 x 870 x 1,000

1. Maximum permissible weight: 50 kg

2. These approximate values are given for individual packages. Packages grouped in open slat crates for quantity of machines supplied > 5, in the majority of cases.

Appendix Configurator



Configurator is a powerful tool to assist you in the selection of motors or geared motors combined with variable speed drives.

- All standard products are 100%-characterised, with print-outs of technical specifications
- Available in 11 languages
- Products dimensions supplied in 3D
- Real-time information on the eligibility of the product for the Express Availability offering.

To register in line:
<http://configureurls.leroy-somer.com>

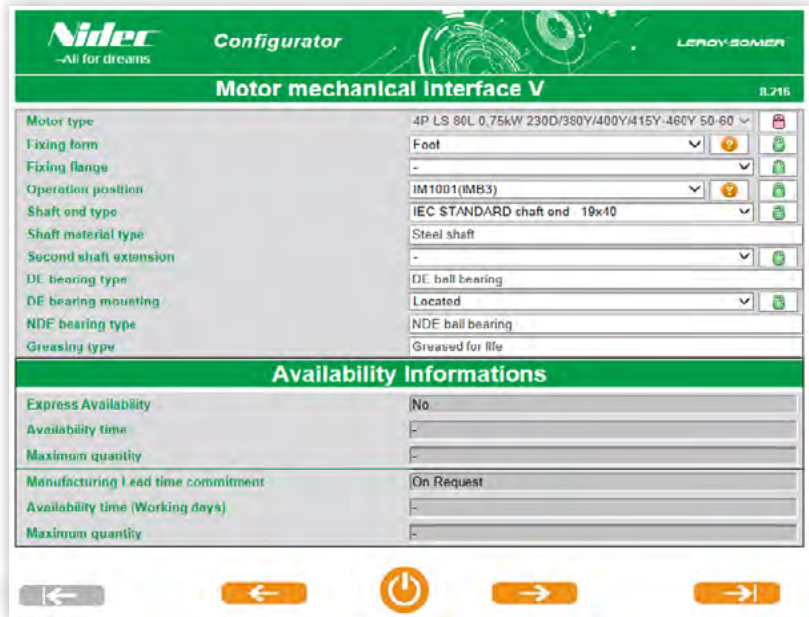

Product availability

Express Availability - FFB brake motors

IMfinity® motors and FFB brake IFT/NIE (Not in any efficiency class) motors in Italica excepted NC; Not Covered by IE Standards - U.G. Standard environment

AVAILABILITY TIMES EX WORKS (FRANCE), IN WORKING DAYS
 For products with options, availability will be that of the longest lead-time item i.e; the product or its options.
 If the order is received after 12:00 pm 1 working day on the mentioned availability will be added.
 The maximum quantity is per line of order. Above this maximum quantity, please consult your Sales Office.

Product	D	D+1	D+2	D+5	D+10
230/400 V 50 Hz + IP23-Class F-180VDC Built-in brake power supply - Factory set braking torque	Green	Yellow	Blue	Grey	Blue
400 V 50 Hz + option Factory ventilation VF	Green	Yellow	Blue	Grey	Blue
400 V 50 Hz + option Factory ventilation VF	Green	Yellow	Blue	Grey	Blue
230/400 V 50 Hz + 0V 1024 pps TTL Incremental Encoder option	Green	Yellow	Blue	Grey	Blue
400 V 50 Hz + 0V 1024 pps TTL Incremental Encoder option	Green	Yellow	Blue	Grey	Blue
400 V 50 Hz + 0V 1024 pps TTL Incremental Encoder option	Green	Yellow	Blue	Grey	Blue
230/400 V 50 Hz + 0V 1024 pps TTL Incremental Encoder option	Green	Yellow	Blue	Grey	Blue
400 V 50 Hz + 0V 1024 pps TTL Incremental Encoder option	Green	Yellow	Blue	Grey	Blue
230/400 V 50 Hz + 0V 1024 pps TTL Incremental Encoder option	Green	Yellow	Blue	Grey	Blue
400 V 50 Hz + 0V 1024 pps TTL Incremental Encoder option	Green	Yellow	Blue	Grey	Blue
400 V 50 Hz + 0V 1024 pps TTL Incremental Encoder option	Green	Yellow	Blue	Grey	Blue
400 V 50 Hz + 0V 1024 pps TTL Incremental Encoder option	Green	Yellow	Blue	Grey	Blue

AVAILABILITY TIMES EX WORKS (FRANCE), IN WORKING DAYS
 Orders received, within the maximum quantity limit, by the factory on day D before 12:00 pm Central European Time, will have the following Availability.
 For products with options, availability will be that of the longest lead-time item i.e; the product or its options.
 If the order is received after 12:00 pm 1 working day on the mentioned availability will be added.
 The maximum quantity is per line of order. Above this maximum quantity, please consult your Sales Office.

D	D+1	D+2	D+5	D+10	Please consult
---	-----	-----	-----	------	----------------

Being able both to respond to urgent requests and adhere to promised customer lead times calls for a powerful logistics system.

The «Express Availability» selection data specify the product lead time for each family in the form of a color code and according to the quantities per order.

The availability of motors is ensured by the network of approved partners and Nidec Leroy-Somer central services all working together.

To verify if your country is covered by the Express Availability offer or by the 24H Express transport, please contact your local Automation Center.

LEROY-SOMER[™]

www.leroy-somer.com

Connect with us at:

twitter.com/Leroy_Somer_en

facebook.com/leroy-somer.nidec

youtube.com/user/LeroySomerOfficiel

linkedin.com/company



Nidec
All for dreams

© 2022 Moteurs Leroy-Somer SAS. The information contained in this brochure is for guidance only and does not form part of any contract. The accuracy cannot be guaranteed as Moteurs Leroy-Somer SAS have an ongoing process of development and reserve the right to change the specification of their products without notice.

Moteurs Leroy-Somer SAS. Headquarters: Bd Marcellin Leroy, CS 10015, 16915 Angoulême Cedex 9, France. Share Capital: 38,679,664 €, RCS Angoulême 338 567 258.



Distributor

LEROY-SOMERTM

<https://motorielettrici.elleuno.eu>

info@elleuno.eu

Phone +39 028131848

Fax +39 0289190444

ELLEUNO s.r.l.

Via Bari 24 20143 MILANO Italy