

## **(F)LS (ES, IA, MV, PX), FCR** **3-phase asynchronous TEFV brake motors** **Maintenance**

# (F)LS (ES, IA, MV, PX), FCR

## 3-phase asynchronous TEFV brake motors

This document complements the general instructions ref. 1889 (recommendations), ref. 3770 (LS), ref. 4850 (LSES LS2/IE2), ref. 3255, 3385 (ATEX specific recommendations) and the specific instructions ref. 2908 (FCR brake motor installation).



FCR brake motors are monobloc units consisting of an induction motor and a failsafe brake system (safety brake).

This motor benefits from the experience of one of the largest manufacturers in the world, using state-of-the-art technology in automation, specially selected materials, rigorous quality control. As a result, the regulatory authorities have awarded our motor factories the ISO 9001 - Edition 2008 international certificate.

EC conformity: motors conform to the harmonized standard EN 60034 (IEC 34) therefore with the low voltage Directive 2006/95/EC and as EC marked.

The noise level of the machines, measured under normal conditions, conforms to the requirements of the standard (IEC 34-9).

### IMPORTANT

These symbols   appear in this document whenever it is important to take special precautions during installation, operation, servicing or maintenance of the motors.

 The specifications, instructions and descriptions are for standard operation. They do not take account of structural variants or special adaptations. Failure to comply with these recommendations may lead to premature deterioration of the motor and voiding of the manufacturer's guarantee.

Check motor compatibility with its environment before installation and over its entire operating lifetime.

 Electric brake motors are industrial products. Therefore, they must only be installed by qualified experienced and authorised personnel. The safety of people, animals and goods should be ensured when fitting the motors into machines (please refer to current standards).

Particular attention should be given to the equipotential ground or earthing connections.

**Workforce safety:** protect all rotating devices before power-up. If running a motor without fitting a coupling device, carefully immobilise the key in its location. All measures must be taken to ensure protection from the risks presented by rotating parts (sleeve, pulley, belt, etc.). Beware of backdriving when the motor is switched off, it is necessary to take appropriate precautions: pumps, install a non-return valve, for example.

 The following precautions must be taken before working on any stopped device:

- mains voltage disconnected and no residual voltage present
- careful study of the causes of the stoppage (blocked transmission - loss of phase - cut-out due to thermal protection - lack of lubrication, etc.)

### PREFACE: ATEX TRAINING



Specific ATEX marking <sup>10</sup>

**0080** : INERIS identification number (Notified Organisation)

 : Specific marking

**II 2D Ex tb IIIC** : Group II, category 2, Dust or:

**II 3D Ex tc IIIB** : Group II, category 3, non-conducting Dust

Those persons required to work on electrical installations and equipment in zones where there is a risk of explosion must be specially trained in the necessary skills.

In effect, they must be familiar not only with the electrical risks, but also with those that are due to the chemical properties and physical characteristics of products used in the installation (gas, vapour, dust), as well as the environment in which the equipment operates. These elements dictate the risk of fire and explosion.

In particular, they must be informed and aware of the specific safety reasons and requirements in order to adhere to them.

For example:

- do not open when powered up,
- do not open when powered up in atmospheres containing explosive dust,
- do not separate when powered up,
- do not manoeuvre when on load,
- wait several minutes before opening,
- replace the seals tightly to ensure watertightness.

### CONTENTS

<b>1 - IDENTIFICATION</b> .....	13
1.1 - Standard nameplate .....	13
1.2 - Marking .....	13
<b>2 - EXPLODED VIEW AND PARTS LIST FOR FCR BRAKE MOTORS</b> .....	14
2.1 - Exploded view for FCR brake motors .....	14
2.2 - Parts list for FCR brake motors .....	14
<b>3 - SPARE PARTS</b> .....	14
3.1 - Procedure .....	14
3.2 - Wearing parts .....	14
<b>4 - MAINTENANCE</b> .....	15
4.1 - Dismantling for FCR brake motors .....	15
4.2 - Reassembly for FCR brake motors .....	15
4.3 - Adjustments .....	15
4.4 - Braking torque .....	15
4.5 - Electro-magnet characteristics .....	16
4.6 - Special operating conditions .....	16
4.7 - ATEX operating .....	16
<b>5 - TROUBLESHOOTING GUIDE</b> .....	17
<b>6 - WIRING DIAGRAMS</b> .....	18-19

**NOTE :** Leroy-Somer reserves the right to modify its product characteristics at any time to incorporate the latest technological developments. The information contained in this document may therefore be changed without prior warning.

Copyright 2008 : MOTEURS LEROY-SOMER. This document is the property of MOTEURS LEROY-SOMER. It cannot be reproduced in any form without prior authorisation. All brand names are registered trademarks.

# (F)LS (ES, IA, MV, PX), FCR

## 3-phase asynchronous TEFV brake motors

### 1 - IDENTIFICATION

#### 1.1 - Standard nameplate

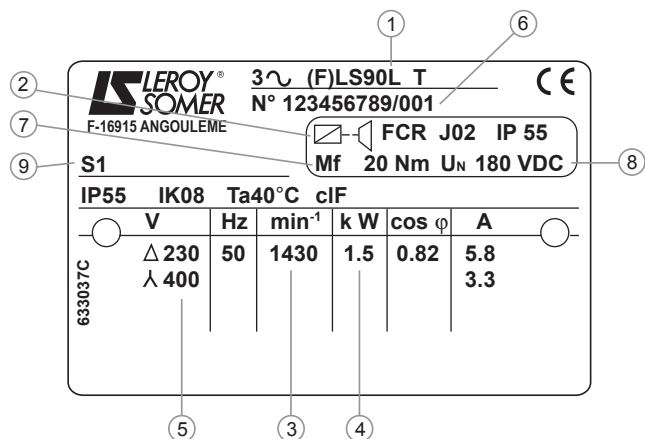

Following details indicated on name plate:

Motor series, frame size	①
Brake type (FCR J02)	②
Speed rotation (min <sup>-1</sup> )	③
Rated power (kW)	④
Motor voltage (V)	⑤
Manufacturing number	⑥
M <sub>r</sub> Braking torque (N.m)	⑦
U <sub>N</sub> Brake coil voltage (V)	⑧
Duty cycle (S1)	⑨
Specific ATEX marking	⑩
(F)LS(IA) : Food processing industry	Option

IP55 IK08 / IP65 IK08 : Index of protection\*

- S1 : Duty
- % : Duty (operating) factor
- ...C/h : Number of cycles per hour
- 40 °C : Contractual ambient operating temperature
- (I) cl. F : Insulation class F
- Hz : Supply frequency
- kW : Rated output power
- cos φ : Power factor
- A : Rated current
- Δ : Delta connection
- Y : Star connection

#### Shock resistance

The motor can stand a weak mechanical shock (IK 08 according to EN 50-102). The user must provide additional protection if there is a risk of greater mechanical shock.

#### Specific ATEX marking

- 0080 : INERIS identification number (Notified Organisation)
- ⊕ : Specific marking
- II 2D Ex tb IIIC : Group II, category 2, Dust or:
- II 3D Ex tc IIIB : Group II, category 3, non-conducting Dust
- T125°C : Maximum surface temperature: 125°C
- Db, Dc : Protection level of equipment
- Ta : Ambient temperature: -25°C; 40°C for example
- Attestation n° : Type test attestation n° issued by INERIS

### 1.2 - Marking

Ensure that the nameplate conforms with the order specifications on receipt of the motor.

#### LS(ES) FCR

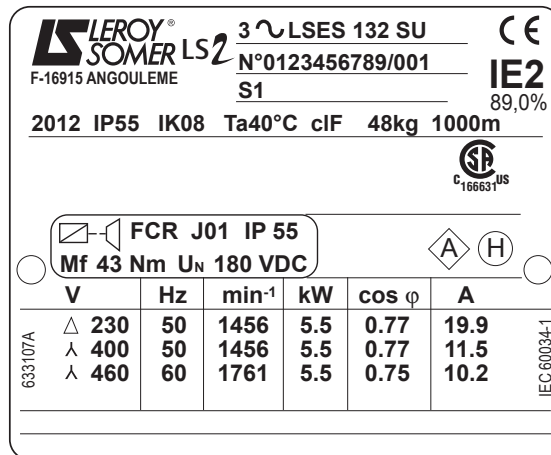

#### ATEX Zone 22 : (F)LS FCR

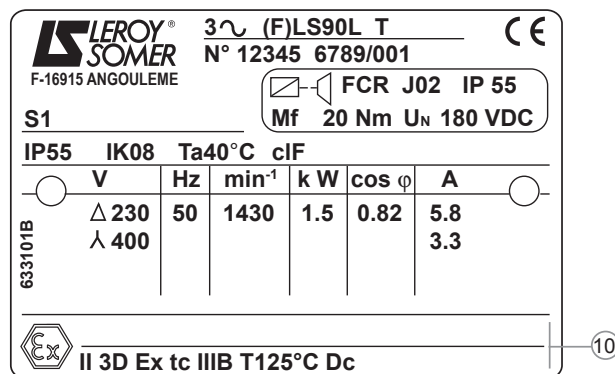

#### ATEX Zone 21 : (F)LS(PX) FCR

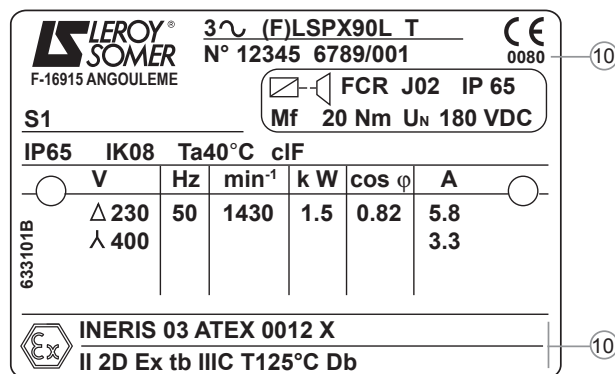

INERIS n° 03ATEX 0012X only applies to FCR brake

 Legal mark indicating that the equipment conforms to the requirements of the European Directives.

# (F)LS (ES, IA, MV, PX), FCR

## 3-phase asynchronous TEFV brake motors

### 2 - EXPLODED VIEW AND PARTS LIST FOR FCR BRAKE MOTORS

#### 2.1 - Exploded view for FCR brake motors

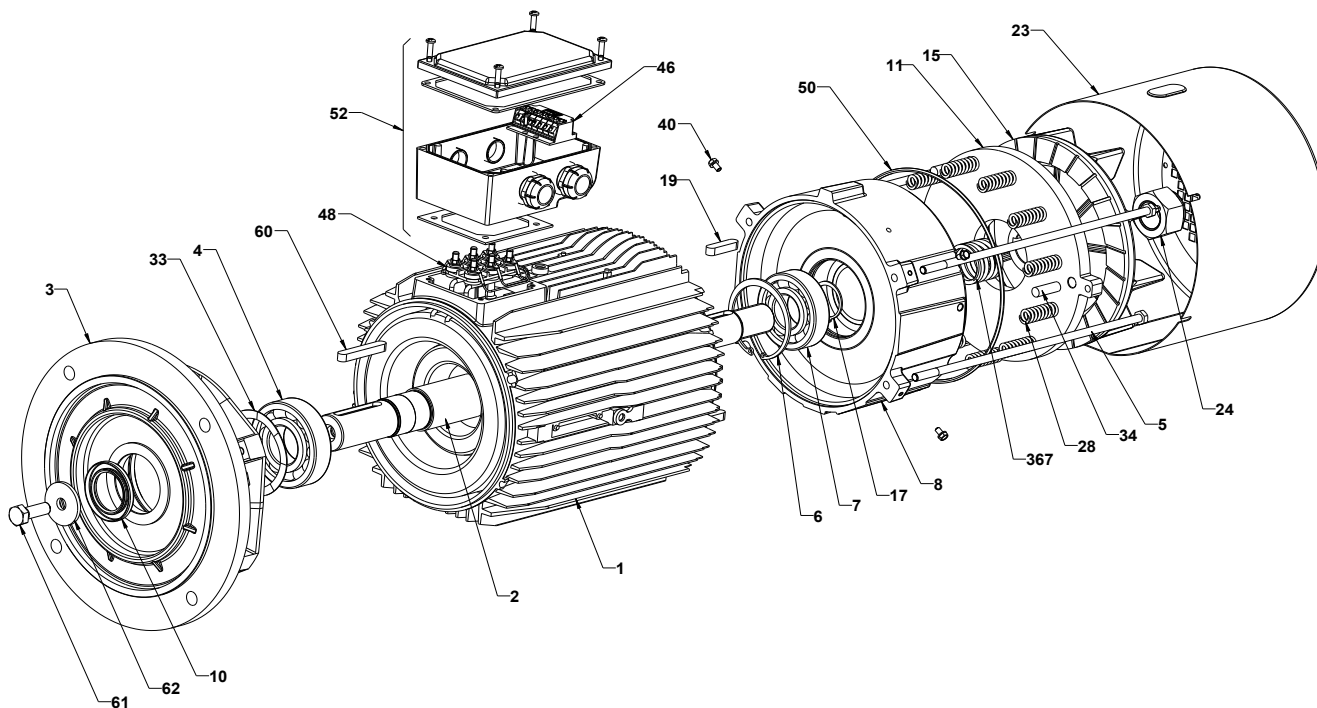

#### 2.2 - Parts list for FCR brake motors

Ref.	Description	Qty	Ref.	Description	Qty	Ref.	Description	Qty
1	Stator housing	1	11	Armature	1	40	Cover screws	3
2	Rotor shaft	1	15	Brake lining fan	1	46	Brake power supply unit	1
3	Front shield	1	17	External circlip	1	48	Motor terminal block	1
4	D.E. bearing	1	19	Keys	2	50	Sealing ring	1
5	Assembly rods	3 to 4	23	Steel cover (IA : ABS)	1	52	Terminal box	1
6	Internal circlip	1	24	Brake nut	1	60	D.E. key	1
7	Brake bearing	1	28	Brake springs	3 to 6	61	D.E. screw	1
8	Brake shield	1	33	Flexible washer	1	62	D.E. washer	1
10	Seal	1	34	Splined pins	3	367	Spring holder (frame132)	1

### 3 - SPARE PARTS

#### 3.1 - Procedure

All orders for replacement parts must quote:

- the complete motor type, its number and the information given on the nameplate (see §1);
- number and designation of parts (the part numbers can be found on the exploded view § 2.1 and their description in the parts list § 2.2).

In the case of flange mounted motors indicate the type of flange and its dimensions Ø PCD (B5 for flange-mounted, B14 for facemounted or MI integral mounting) and details of gearbox, when fitted.

**In order to ensure the safety and good working order of our brake motors, we recommend the use of original manufacturer replacement parts.**

**If this advice is not followed, the manufacturer cannot be held responsible for any subsequent damage.**

#### 3.2 - Wearing parts

Parts number	LS 71 FCR	(F)LS 80 FCR	(F)LS 90 FCR	(F)LS 100 FCR	(F)LS 112 FCR	LS 132 S FCR	(F)LS 132 M FCR	LS 160 FCR
4	6004 2RS	6204 2RS	6205 2RS	6206 2RS	6206 2RS	6208 2RS	6308 2RS	6309 2RS
7	6202 2RS	6204 2RS	6205 2RS	6205 2RS	6206 2RS	6206 2RS	6307 2RS	6307 2RS
10	20 x38 x 8	20 x 38 x 8	25 x 40 x 7	30 x 47 x 5	30 x 48 x 8	40 x 62 x 7	40 x 62 x 7	72 x 45 x 8
11	armature							
15	brake lining fan							
34	splined pin							
50	101.19 x 3.53	120 x 4	136.12 x 3.53	136.12 x 3.53	164.7 x 3.53	164.7 x 3.53	209.14 x 3.53	209.14 x 3.53

# (F)LS (ES, IA, MV, PX), FCR

## 3-phase asynchronous TEFV brake motors

### 4 - MAINTENANCE

 Always disconnect the brake motor from its power supply before working on the brake.

#### 4.1 - Dismantling for FCR brake motors

- Dismantle the brake motor using the correct tools (hub remover, bearing remover, plastic or leather mallets, correctly sized keys and screwdrivers, circlips pliers, etc.).
- Disconnect the brake motor from its power supply.
- Open the terminal box, locate the wires and mark their position (power supply to the motor and the brake, probes, etc.).
- Disconnect the power supply wires from the motor terminal block and the brake power supply unit (+ and - terminals).
- Unscrew the handle of the lever **53.1** when fitted (following procedure §4.2).
- Unscrew the cover screws **40**, remove the steel cover **23**.
- Remove the brake nut **24**.
- Remove the sealing ring **50**.
- Place an extractor with 2 arms pressing on the end of the shaft and two arms on the armature pins 11.
- Remove the brake lining fan **15** and the armature **11**.
- Mark the position of the springs **28** and remove them.
- Unscrew the assembly rods **5**.
- Put aside the front shield **3**.
- Pull out the stator housing **1** taking care not to damage the winding.
- Remove the internal circlip **6** to free the brake shield **8**.
- Clean the parts:
  - by blowing the electrical parts (do not use solvents or products containing moisture);
  - using a non slippery degreasing agent for the mechanical parts;
  - using a scraper for the flanges;
  - if parts **11** and **15** are slippery: change part **15** and degrease part **11** with a non slippery degreasing agent.
- Change the seals and the bearings.
- Disconnect the bridge rectifier and check the insulation of the stator (>10 megOhms).
- Mark all faulty parts so that replacement parts can be ordered.

#### 4.2 - Reassembly for FCR brake motors

- Lightly grease the shafts and bearing cages.
- Cover the seal lips with grease and put the seal back carefully (use the protection sockets of the drive shaft keyway).
- Working in reverse order, assemble the motor.
- Replace the pressure springs **28**, change the sealing ring **50**.
- Position the housing **11**, reposition the brake lining fan **15**.
- Adjust the air gap (see above).
- Position the sealing ring **50**.
- Fit on the lever **53** (following procedure bellow).
- Replace the steel cover **23** and fix it using the cover screws **40**.
- Reconnect the brake power supply unit, and any probes, and then the motor - making sure that the wires are in the correct order - and close the terminal box.
- Check that it works correctly (if this is not the case check that the release lever is in the right position before coupling to the machine).

#### Desmantling, reassembling the brake lever (option: DLRA)

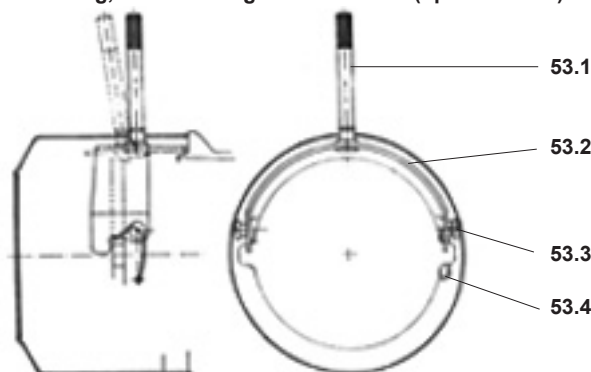

#### Desmantling the brake lever DLRA

- Unscrew the handle of the lever **53.1** (if fitted on the hand release lever).
- Unscrew the cover screws **40**, which keep the cover **23** in place.
- Unscrew the two screws **53.3**, release the spring **53.4**.
- The hand release **53.2** may be removed.

#### Reassembling the brake lever DLRA

- Position the hand release **53.2** around the brake housing.
- Assemble the screw on the right **53.3** (when viewed from the output shaft of the motor).
- Assemble the other screw **53.3** and get ready with the spring **53.4**.
- Compress the spring **53.4** close to the maximum distance larger than the section of brake lever **53.2** and smaller than the distance between the screws on the brakes housing.
- Assemble the cover **23** and the screws **40**.
- The handle **53.1**, clipped to the stator, will be assembled, if needed to release the brake.

### 4.3 - Adjustments

#### Adjusting the air gap

- The air gap needs to be adjusted when the release mechanism no longer functions normally.
- Unscrew the handle of the lever **53.1** when fitted (following procedure §4.2).
  - Unscrew the cover screws **40** which keep the steel cover **23** in place.
  - Remove the steel cover **23**. Unscrew the brake nut **24**, and remove the sealing ring **50**. Clean the parts: removal of lining's friction dust. Insert a 0.4 mm shim between the brake shield **8** and the armature **11**. Tighten the brake nut **24** so as to obtain working play of 4/10th between armature **11** and brake shield **8** (the shim should slip slightly).
  - The brake nut **24** should be changed after 3 adjustments.
  - Replace the sealing ring **50**. Replace the lever **53** (following procedure §4.2).
  - Replace the steel cover **23** and tighten the cover screws **40**.

#### Adjusting the braking torque

- The braking torque depends on the number of springs and their colour; use the values shown in the table on §4.4.

### 4.4 - Braking torque (N.m values given for indication only ; in case of Standards' limitation, please consult us)

No. of springs	LS 71 FCR		(F)LS 80 FCR		(F)LS 90 FCR		(F)LS 100 FCR		(F)LS 112 FCR		LS 132S FCR		(F)LS 132M1 FCR		LS 160' FCR	
	Colour	N.m	Colour	N.m	Colour	N.m	Colour	N.m	Colour	N.m	Colour	N.m	Colour	N.m	Colour	N.m
3	white	1.2	blue	2	green	4	green	4	orange	16	orange	16	yellow	40	yellow	40
4	white	1.6	blue	3	green	6	green	6	orange	22	orange	22	yellow	50	yellow	50
5	white	2	blue	3.5	green	8	green	8	-	-	-	-	-	-	-	-
6	white	2.4	blue	4.5	green	9	green	9	orange	32	orange	32	yellow	80	yellow	80
8	-	-	-	-	-	-	-	-	orange	43	orange	43	yellow	105	yellow	105
9	-	-	-	-	-	-	-	-	-	-	-	-	yellow	120	yellow	120
12	-	-	-	-	-	-	-	-	-	-	-	-	yellow	160	yellow	160
3	blue	4	green	6	grey	15	grey	15	-	-	-	-	-	-	-	-
4	blue	5	green	8	grey	20	grey	20	-	-	-	-	-	-	-	-
5	blue	6	green	10	grey	25(32*)	grey	25(32*)	-	-	-	-	-	-	-	-
6	blue	7.5	green	12(15*)	-	-	-	-	-	-	-	-	-	-	-	-

<sup>1</sup>(F)LS 132M, LS 160 : braking torque to be chosen between 40 to 80 Nm or 105 to 120 Nm  
 (\*) : with machined armature plate

# (F)LS (ES, IA, MV, PX), FCR

## 3-phase asynchronous TEFV brake motors

### 4.5 - Electro-magnet characteristics (à 20°C) ± 5 %

Brake motor type	DC voltage											
	180 V Brake coil voltage ESFR VMA 33/34 : 180 V			VMA 31/32 : S0 VMA 100 - 120 V			100 V Brake coil voltage			20 V Brake coil voltage		
	Current	Resistance	Power	Current	Resistance	Power	Current	Resistance	Power	Current	Resistance	Power
	A	Ω	W	A	Ω	W	A	Ω	W	A	Ω	W
LS 71 FCR	0.26	698	46.4	0.21	569	25.3	0.45	223	44.9	2.21	9.1	43.9
(F)LS 80 FCR	0.29	612	53	0.28	428	33.7	0.52	194	51.6	2.99	6.7	59.9
(F)LS 90 FCR	0.39	456	71	0.41	293	49.2	0.63	159	63	2.98	6.7	59.7
(F)LS 100 FCR	0.39	456	71	0.41	293	49.2	0.63	159	63	2.98	6.7	59.7
(F)LS 112 FCR	0.41	442	73.3	0.74	134	74.4	0.74	134	74.4	3.76	5.3	75.2
LS 132 S FCR	0.41	442	73.3	-	-	-	0.74	134	74.4	3.76	5.3	75.2
(F)LS 132 (S)M <sup>1</sup> FCR	0.5	364	89.1	-	-	-	1.16	85.9	116	6.62	3	132
(F)LS 132 M <sup>2</sup> FCR	0.75	241	134.2	-	-	-	1.16	85.9	116	6.62	3	132
LS 160 MP, LR FCR	0.75	241	134.2	-	-	-	1.16	85.9	116	6.62	3	132

1. (F)LS 132 (S)M with braking torque = 40 to 80 N.m

2. (F)LS 132 M with braking torque = 105 to 160 N.m

### 4.6 - Special operating conditions

- Thermal protection (see 2908 § 2.6)

- Space heaters (see 2908 § 2.6)

- Temperatures: storage and ambient

Note: Ta = ambient temperature

If it has been stored at a temperature lower than -10°C, heat the motor and turn the shaft manually before operating the machine.

If used at a temperature lower than -25°C, the motor does not require a temperature sensor to be fitted. It can be fitted with thermocouples.

Our standard motors are intended to operate at an ambient temperature between -25°C and 40°C.

- Surface temperature

As standard, the maximum surface temperature of our motors is 125°C with a maximum ambient temperature of ≤ 40°C. Without derating the motor, the maximum surface temperature will be:

- 135°C if 40°C ≤ Ta ≤ 50°C
- 145°C if 50°C ≤ Ta ≤ 60°C

- Contactors - isolators

In all cases, the contactors, isolators, etc. must be installed and connected in an enclosure offering a degree of protection and surface temperature compatible with the installation zone, or outside danger zones (outside zones 20, 21 and 22).

- Connection

Particular attention must be paid to the nameplate so as to choose the correct type of connection for the supply voltage.

- Bearing maintenance

When you detect on the motor:

- a noise or abnormal vibration,
- abnormal temperature rise in the bearing even though it is lubricated correctly, the state of the bearings must be checked.

**Damaged bearings must be replaced as soon as possible** to prevent worse damage to the motor and the driven equipment.

When one bearing needs to be replaced, **the other bearing must also be replaced.**

The free bearing allows the rotor shaft to expand (make sure it is identified during dismantling).

- Seals

**After removing the drain plugs, replace them in order to ensure that the motor conforms to IP 55 or 65 protection.** Replace the removed seals with new seals of the same type. Clean the orifices and plugs before replacing.

On removal, and at least once a year, replace seals on the shaftway, the shield spigots and the terminal box cover with new seals of the same type, after cleaning the parts. The shaftway seals must be fitted using grease of the same type as the bearings.

### 4.7 - ATEX operating

- IP 65 protection for the motor

 Whenever the motor is dismantled, during on-site preventive maintenance, replace the seals for the shaftways, shield spigots, the terminal box cover (if mastic) with new seals of the same type, after cleaning the parts. The shaftway seals must be reassembled using grease of the same type as used on the bearings.

 Whenever the drain plugs are removed, they must be replaced to ensure IP 65 protection for the motor. Replace used seals with new seals of the same type. Clean the orifices and plugs before reassembly.

 After removing the terminal box cover, replace the seal with a new seal of the same type after cleaning the parts if its state no longer guarantees the required degree of protection.

- Variable speed utilisation

Special precautions need to be taken when these motors are powered by a frequency inverter or voltage controller:

 The reference voltage (drive output or motor input) is 400 V at 50 Hz. The drive should deliver a constant voltage/frequency signal to the motor.

 The operating range is limited to 25 to 50 Hz for 50 Hz supplies and for 50 Hz motors designed with natural cooling.

 The drives and probe connection devices must be installed outside danger zones (outside zones 20, 21 and 22).

 Regardless of the number of poles, the speed must never exceed 3 600 min<sup>-1</sup>.

 Motors supplied by a frequency inverter must be fitted with winding sensors and a sensor on the DE shield if appropriate. These sensors must be connected to a motor cut-off device placed outside the explosive zone, so that the maximum surface temperature (indicated on the device) is never reached (Ref. 2908 § 2.6).



Particular points:

- forced ventilation is forbidden.
- incremental encoder utilisation requires ATEX homologation (IP 65) of the encoder.

# (F)LS (ES, IA, MV, PX), FCR

## 3-phase asynchronous TEFV brake motors

### 5 - TROUBLESHOOTING GUIDE

Incident	Possible cause	Action
<b>Abnormal noise</b>	Originating in motor or driven machine?	Uncouple the motor from the driven equipment and test the motor on its own Test the brake release system
<b>Noisy motor</b>	<b>Mechanical cause:</b> if the noise persists after switching off the electrical power supply	
	- vibration	- Check that the key conforms with the type of balancing
	- damaged bearings	- Change the bearings
	- mechanical friction: ventilation, brake disc, coupling	- Check
	<b>Electrical cause:</b> if the noise stops after switching off the electrical power supply	- Check the power supply at the motor terminals
	- normal voltage and 3 phases balanced	- Check terminal block connection and tightening of the connectors
	- abnormal voltage	- Check the power supply line
	- phase imbalance	- Check the winding resistance and the supply (voltage) balancing
<b>Motor heats up abnormally</b>	- faulty ventilation	- Monitor the environment - Clean the fan cover and the cooling fins - Check the fan is correctly mounted on the shaft
	- faulty supply voltage	- Check
	- terminal connection fault	- Check
	- overload	- Check the current consumption against the current shown on the motor nameplate
	- partial short-circuit	- Check the electrical continuity of the windings and/or the installation
	- phase imbalance	- Check the windings resistance
<b>Motor does not start</b>	<b>no load</b>	Release the brake, and with the motor switched off:
	- mechanical locking	- check the shaft rotates freely by hand
	- broken supply line	- check fuses, electrical protection, starting device, electrical continuity
	<b>on-load</b>	When switched off:
- phase imbalance	- check the direction of rotation (phase order) - check the resistance and the continuity of the windings - check electrical protection	
<b>The brake does not release</b>	Insufficient supply voltage:	The maximum permissible voltage drop is 15 % of the rated voltage Change the coil
	Defective coil:	
<b>The brake releases but it is very noisy:</b>	Air gap irregular, or too large:	Dismantle if necessary and clean (see §4)
	Foreign body in the air gap:	Clean the parts
<b>The brake releases but braking is insufficient</b>	Insufficient pressure on springs:	Adjust springs (see instructions §4) and Check for wear on the linings
	Correct pressure on springs:	Check the surface condition of the ring and the brake shield Blow away any friction dust

# (F)LS (ES, IA, MV, PX), FCR

## 3-phase asynchronous TEFV brake motors

### 6 - WIRING DIAGRAMS

#### 1 speed, D.O.L. starting, 50/60 Hz

Built-in power supply : 350 to 460 V, 200 to 265 V  
 Separate power supply : 350 to 460 V, 200 to 265 V, (24 V\*)

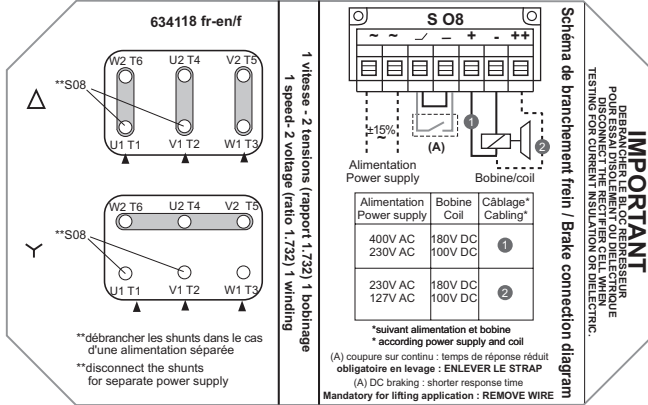

#### 1 speed, Y Δ starting, 50/60 Hz

Built-in power supply : 350 to 460 V, 200 to 265 V  
 Separate power supply : 350 to 460 V, 200 to 265 V, (24 V\*)

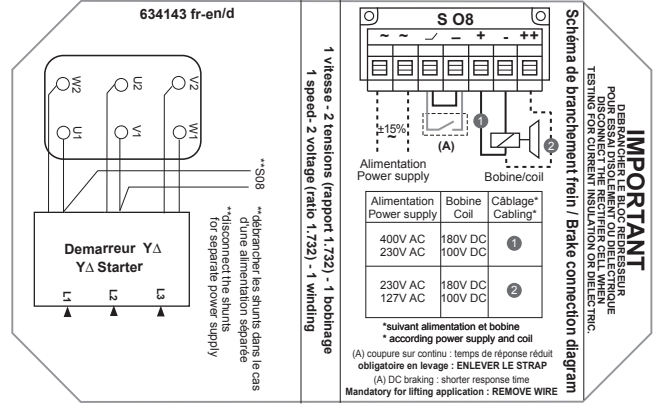

#### 2 speeds Dahlander, 1 voltage, 50/60 Hz

Built-in power supply : 350 to 460 V : coil 180 V  
 Built-in power supply : 200 to 265 V : coil 100 V  
 Separate power supply : 350 to 460 V, 200 to 265 V, (24 V\*)

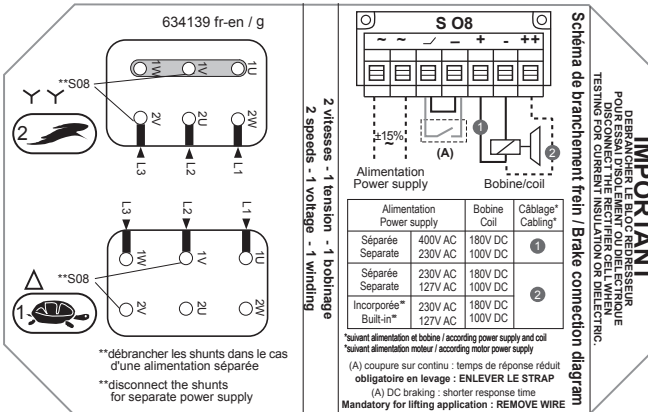

#### 2 speeds, 2 windings, 2 voltage, 50/60 Hz

Separate power supply : 350 to 460 V, 200 to 265 V, (24 V\*)

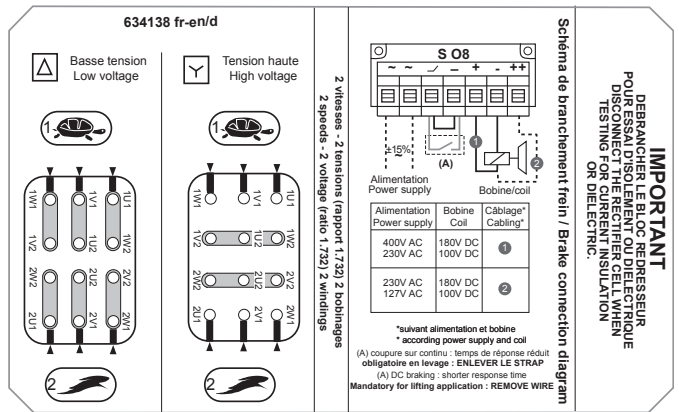

#### 2 speeds, 2 windings, 1 voltage, 50/60 Hz

Built-in power supply : 350 to 460 V : brake coil 180 V  
 Built-in power supply : 200 to 265 V : brake coil 100 V

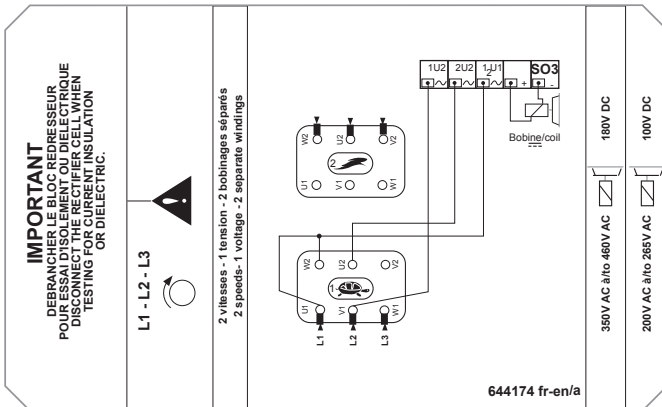

#### 2 speeds, 2 windings, 2 voltage, 50/60 Hz

(Δ/Y) : LS 80 to 160  
 Built-in power supply : 200 to 265 V, brake coil 100 V

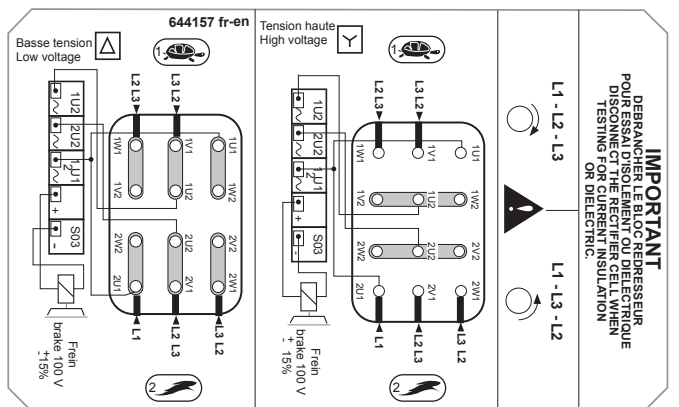



# (F)LS (ES, IA, MV, PX), FCR

## 3-phase asynchronous TEFV brake motors

**2 speeds, 2 windings, 2 voltage, 50/60 Hz**  
( $\Delta/Y$ ): LS 71

Built-in power supply : 200 to 265 V : brake coil 100 V

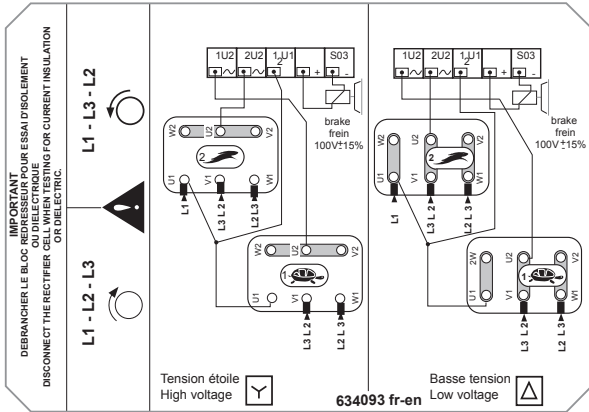

**2 speeds, 2 windings, 1 voltage, 50/60 Hz**

Separate power supply : 350 to 460 V, 200 to 265 V, (24 V\*)

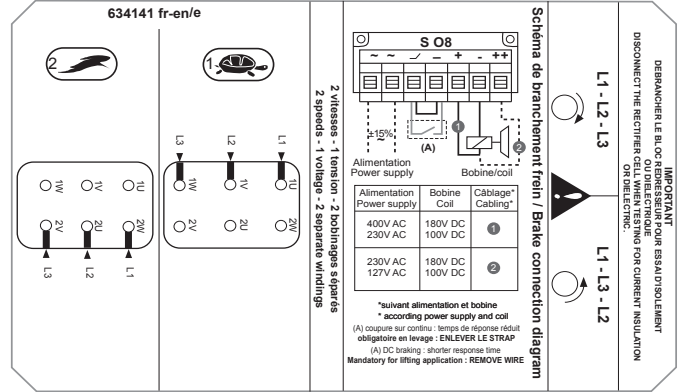

**1 speed, Y  $\Delta$  starting**

Built-in power supply : 350 to 460 V, 200 to 265 V  
Separate power supply : 350 to 460 V, 200 to 265 V, (24 V\*)

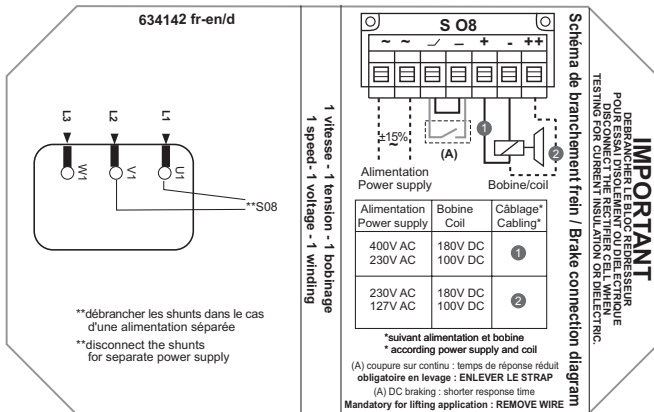

**1 speed, 1 windings, 2 voltage, 50/60 Hz**

Built-in power supply : 400 to 480 V, 200 to 240 V  
Separate power supply : 400 V, 230 V, (24 V\*)

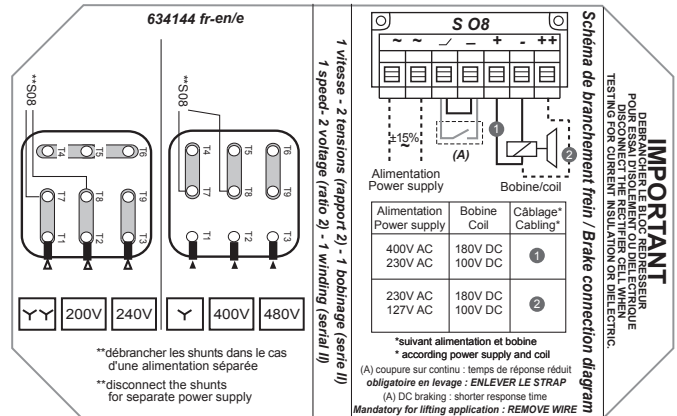

ue



MOTEURS LEROY-SOMER SAS - RCS 338 567 258 ANGOULÊME - CAPITAL DE 65 800 512 €



Distributor

**LEROY-SOMER**<sup>TM</sup>

<https://motorielettrici.elleuno.eu>

[info@elleuno.eu](mailto:info@elleuno.eu)

Phone +39 028131848

Fax +39 0289190444

ELLEUNO s.r.l.

Via Bari 24 20143 MILANO Italy