

## Geared Motors 3000 Range - IMfinity® Compabloc

Drive systems, Non-IE and IE3 efficiency  
Variable speed and fixed speed  
Sizes 15, 30 to 38  
Power rating 0.06 to 110 kW

**LEROY-SOMER™**

***Nidec***  
All for dreams

## Introduction

### GEARBOX OFFERS

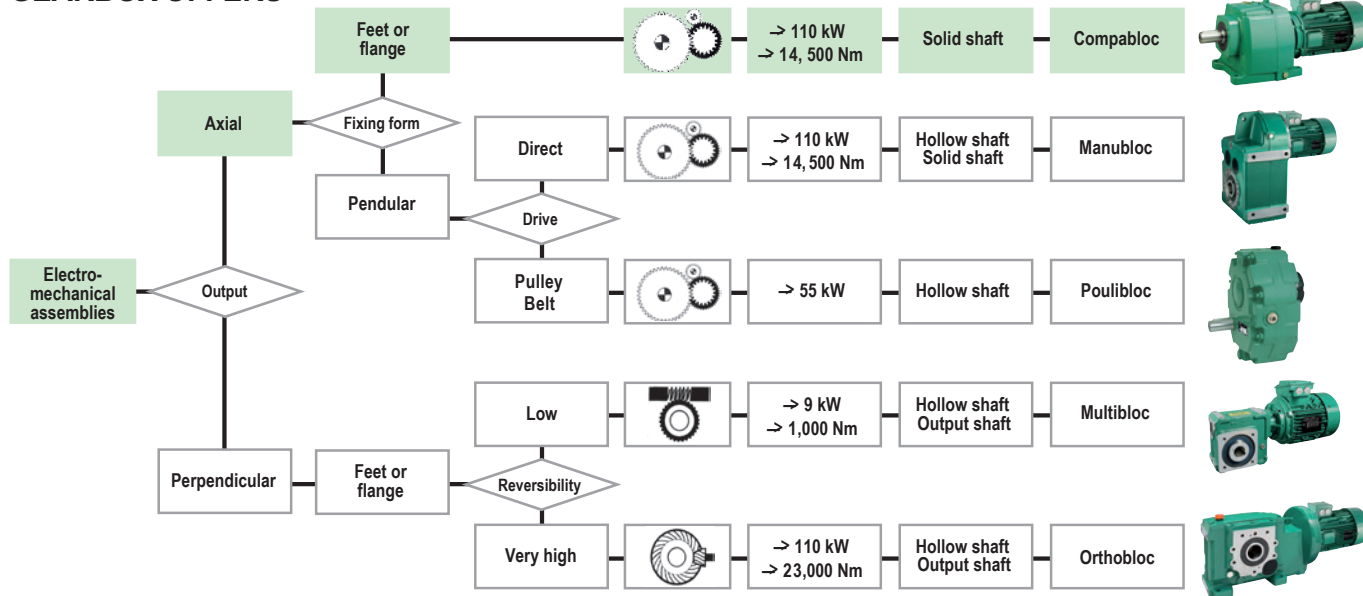

### COMPABLOC RANGE

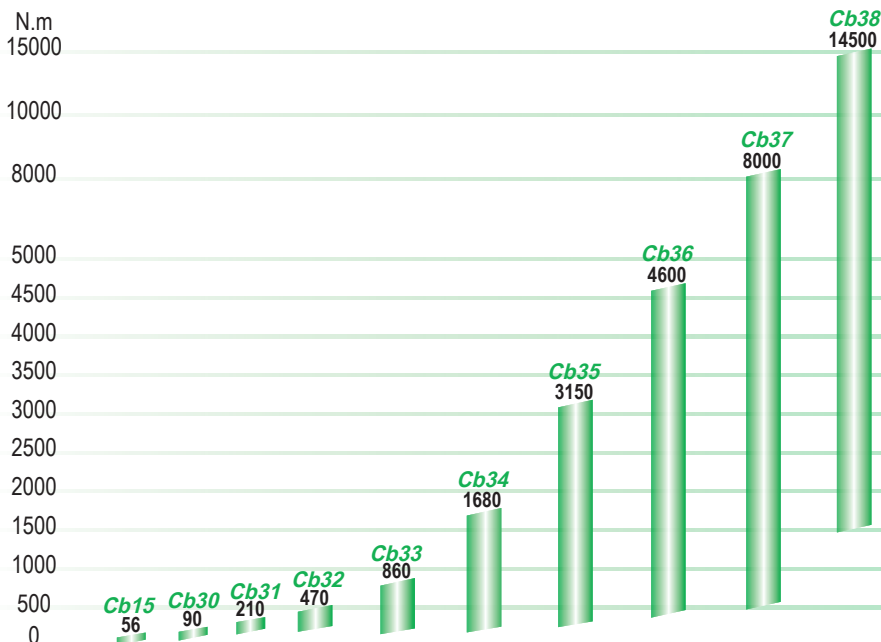
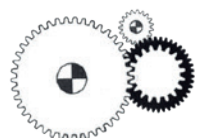

### ASSOCIATED DOCUMENTATIONS

Brochure	Catalogue	Environment			
		Current use		ATEX regulated	
		Commissioning		Ex II 2D / II 3D, Ex II 2G / II 3G 5978 : gearboxes for potentially explosive atmospheres	
		Installation	Maintenance	Ex II 3D II 2D ex-3744: gearboxes for potentially explosive dust atmospheres	Ex II 3G, 3GD, II 2G, 2GD ex-3804: gearboxes for potentially explosive gas atmospheres
3969: range 3000 Compabloc, Orthobloc, Manubloc 5679: electromechanical drive systems	3521: Compabloc 3000 IMfinity® 5181: electromechanical manual	2557: storage and commissioning 3005: Cb 15 3520: Compabloc 3000 5088: lubrication kit 5217: heat exchanger	5060: Compabloc 3000 3005: Cb 15		

## Introduction

### RANGES OF MOTORS AND ASSOCIATED BRAKES

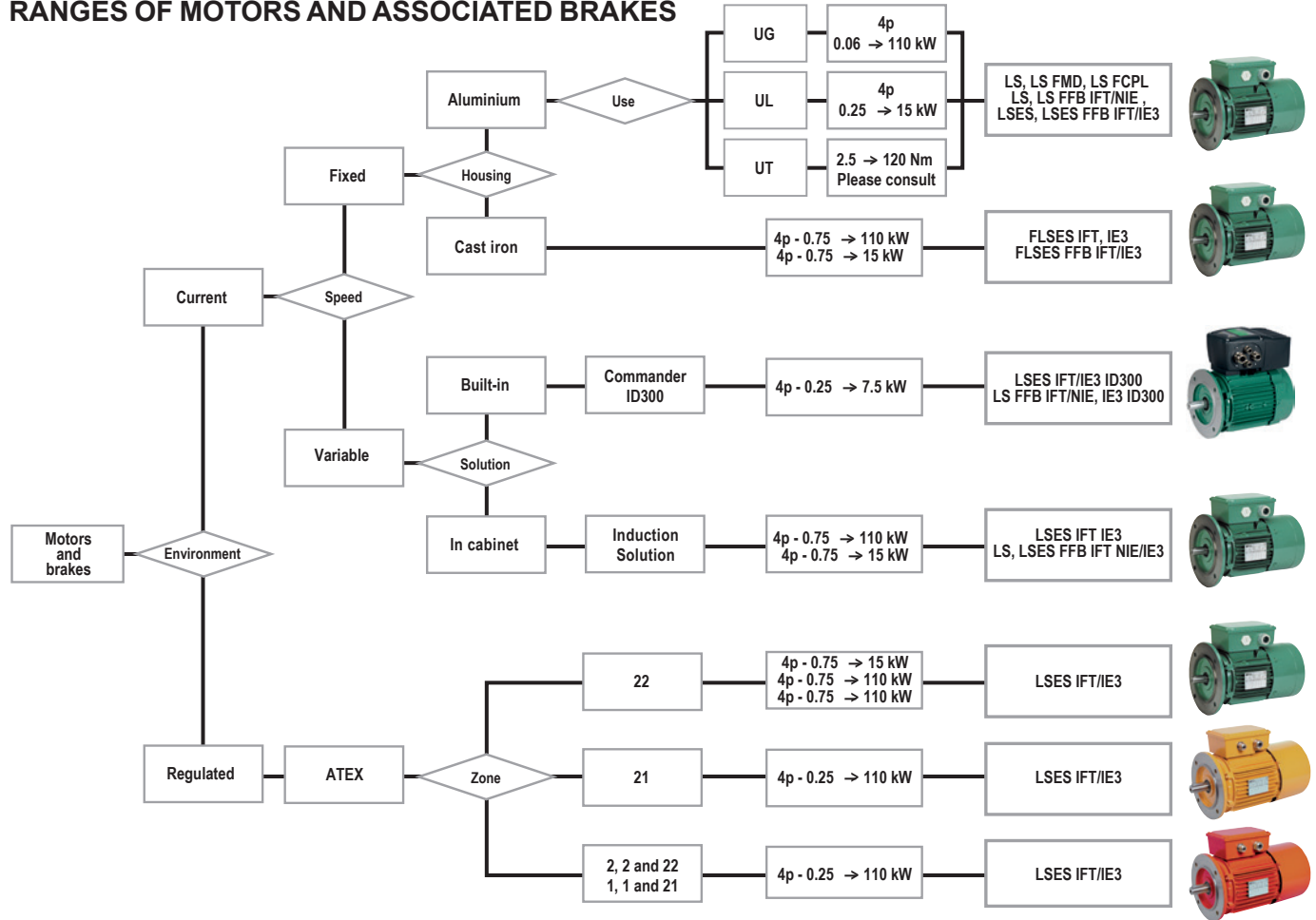

### RANGES OF ASSOCIATED DRIVES

	Starter	Drive cabinet variable speed	Built-in variable speed
110 kW	Digistart	Commander C / Unidrive M M700	Powerdrive MD2M
75 kW >			
45 kW >			
> 22 kW			
> 11 kW			
7,5 kW	C300	M600	F300
2,2 kW >			
1,1 kW			
0,37 kW >	C200		
0,25 kW >			
			> 7,5 kW > 4 kW 2,2 kW > 1,5 kW 0,37 kW > 0,25 kW >
			400V / 3-ph 230V / 3-ph 230V / 1-ph <b>Commander ID300</b>



## Contents

### INTRODUCTION

Offer, range .....	2 - 3
Contents .....	4
Index .....	5
Glossary .....	6

### CONSTRUCTION

Description .....	7
Fixing type and operating position .....	8 to 11

### COMPABLOC: Cb AP

<b>Selecting a input shaft AP gearbox</b> .....	12
Duty factor choice .....	12
Gearbox selection .....	12
Operating position .....	12
Radial load check.....	12
Choice of options .....	12
Example of selection .....	12
<b>Designation</b> .....	13
<b>Selection tables</b> .....	14 to 17
<b>AP dimensions</b> .....	18

### COMPABLOC: Cb / LS, LSES

<b>Selecting a geared motor</b> .....	19-20
Determining the power (or torque) necessary .....	19
Determining the duty factor required .....	19
Determining the type of geared motor required .....	19
Verification .....	19
Operating position .....	19
Example of selection .....	19-20
<b>Designation</b> .....	21

### Selection tables

Cb/LS, LSES - 4 poles - 0.06 to 110 kW .....	22 to 111
<b>Dimensions Cb 1 stage</b> .....	112 to 123
<b>Dimensions Cb 2, 3 stages</b> .....	124 to 145
<b>Dimensions combined Cb</b> .....	146-147
<b>Dimensions Cb MU</b> .....	148
<b>Synthesis</b> .....	149

### EQUIPMENT AND OPTIONS

<b>Backstop</b> .....	150
<b>Heat exchanger</b> .....	150
<b>Feet and Flange shape</b> .....	151 - 152

### IDENTIFICATION - INSTALLATION

#### Identification

Gearbox nameplate .....	153
Motor nameplate .....	154 - 155
Brake nameplate .....	156 - 157

#### Installation

Acceptance .....	158
Materials handling.....	158
Storage .....	158
Commissioning .....	158
Lubrication .....	158
Packaging weight and dimensions .....	159

### APPENDICES

Configurator .....	160
Service for drive systems .....	161
Express availability .....	162



## Index

---

<b>A</b>		<b>I</b>	
Atex .....	2-3-156	IEC.....	7
Atmosphere .....	7	Induction brake motors .....	3-7-22 to 146-156-157
Axial load .....	19	Input shaft AP.....	7-12 to 18
<b>B</b>		Input speed .....	7-12
Backstop AD .....	13-14-22-150	ISO .....	7-153
Brake .....	3-7-22 to 111-156-157	<b>L</b>	
Built-in mounting MI .....	7-8 to 11-19 to 147	Lubrication kit .....	158
<b>C</b>		Lubrication .....	150-158
Cable glands.....	7 to 11	<b>M</b>	
CE.....	155 to 157	Maintenance .....	2-158 - 162
Characteristics.....	7	Motor .....	7-20 to 148-154-155
Combined Mounting Cb .....	22 to 88-146-147	Motor polarity.....	3-7
Contents .....	4	Mounting.....	7- 8 to 11-13-21
CSA .....	156	<b>N</b>	
<b>D</b>		Nameplates .....	154 to 157
Dimensions .....	8-10-18-112 to 149	NFE .....	7
DIN .....	7	<b>O</b>	
Direction of rotation .....	13-21-150	Oil .....	150-153-158
Duty factor .....	12-19-22 to 111	Operating positions.....	8 to 11-12-13-19 to 21
<b>E</b>		Output shaft .....	7-12-13-22 to 111
Efficiency .....	7-19	<b>P</b>	
Electromechanical .....	2	Paint .....	7
Equipment .....	150 to 152	<b>R</b>	
<b>F</b>		Radial load .....	12 - 22 to 111
FCPL .....	3-7-96 to 111-157	Reversibility .....	7
Feet shape.....	8-9-113 to 147	<b>S</b>	
FFB.....	3-7-26 to 95-156	Selection tables .....	14 to 17 - 22 to 111
Fixing types.....	8 to 11-19	Services .....	160 to 163
Fixing .....	8 to 11	Storage.....	158
Flange shape .....	10-11-112 to 147	<b>T</b>	
FMD.....	3-7-22 to 34	Terminal box.....	7 to 11
<b>G</b>		Thermal reserve.....	150
Gear trains.....	7	<b>U</b>	
Gearbox options .....	13-21-150 to 152	Universal Mounting MU.....	7-8 to 11-15-22 to 111-148
Gearbox ranges.....	2		
Gearbox.....	2-7		
Glossary .....	5		
<b>H</b>			
Heat exchanger .....	150		
<b>I</b>			
Identification .....	153 to 157		

## Glossary

AP	Input shaft	LS	Aluminium serial motor not in any efficiency class or not concerned by the IE
BA	Shaft extension		
BS, BD, BR, BT	Flange fixing		
Cb	Compabloc	LSES	Aluminium serial motor IE3
D	Shaft diameter (mm)	m	load weight (kg)
Dim	Dimensions (mm)	$M_{eq}$	Equivalent torque
		M	Permissible torque
		$M_S$	Output torque
E	Output shaft length (mm)	MU	Universal Mounting
FJ	Inertia factor	N	Rotation speed (drum, rollers, motors... in revolutions per minute)
FLSES	IE3 cast iron serial motor		
$F_R E/2$	Permissible radial load at E/2		
HA	Frame size	$N_E$	Input speed
h/j	hour/day	$N_S$	Gearbox output speed
		$N_{uS}$	Useful output rotation speed
i	Exact reduction of gearbox	O.p	Shaft end borehole
laR	Reduction ratio (approached)		
lu	Reduction available to the application	P	Input power (kW)
IP, IK	Protection indexes	$P_{eq}$	Equivalent power
		$P_{uE}$	Useful input power
J	Moment of inertia	h	Efficiency
$J_{c/m}$	Moment of inertia of the load applied to the drive shaft expressed in kg.m <sup>2</sup>		
		S	Solid shaft
$J_m$	Moment of inertia of the motor	S B3/B8/B6/B7/V5/V6	Foot mounting followed with operating position encoding
K	Overall duty factor		
Kp	Maximum possible duty factor for the geared motor	U.G.	General use
		U.L.	Hoisting use
kW	Kilo Watt	U.T.	Displacement use
		Z (d/h)	Starting frequency of the application (d/h)

## General



Compabloc geared motors with parallel gear stage adapt the electric motor speed to the machine driven.

Therefore, they are determined by the motor power (P) expressed in kilowatts (kW) and the gearbox output rotation speed (N<sub>S</sub>) in revolutions per minute (min<sup>-1</sup>).

The characteristic quantity of the gearboxes is the rated output torque (Mn<sub>S</sub>) expressed in Newton-meter (N.m):

$$Mn_S = \frac{P \times 9550}{N_S} \times \text{efficiency}$$

A range with ten sizes: 15, 30, 31, 32, 33, 34, 35, 36, 37, 38

Rated output torque: 10 N.m to 14,500 N.m

Power: from 0.06 to 110 kW

Reduction ratios: from 1.16 to 252

High efficiency: 95 % to 98 %

Reversible

Silent operation

Component	Materials	Remarks
Housing	Aluminium (15, 30) Cast iron ENGJL-200 (31 to 38)	- use of die-cast aluminium - use of cast iron (ENGJL-200 : lamellar graphite, 200 MPa on traction) single component perlite to ensure unit is fully sealed - monobloc ribbed with internal reinforcements to absorb vibrations and noise, and increase its rigidity - with S baseplate, BT form (Cb 15, 30 to 35) or with BS, BD flanges. They are compact and meet industrial requirements
Gears	Steel Ni Cr Mo	- cut by the gear hob, they are heat treated and then undergo final machining. The quality and precision of the gear cutting allow maximum torque with minimum noise level
Lipseals	Nitrile	- sealing ring motor side - sealed gasket with dustproof lipseal in DIN 3760 form AS - gasket under access cover on top (30 to 35)
Shaft	Steel	- grinding of sealing surfaces - key in accordance with ISO R773 - tolerance of diameters in accordance with NFE 22-051 and ISO R775 - tapped holes at the shaft end for fixing connecting devices in accordance with DIN 332
Lubrication	Oil	- in accordance with ISO 6743 / 6 - delivered with the quantity of oil corresponding to the operating position, it is fitted with drain, level and vent plugs (Cb 15 and 30-- excepted)
Mounting		- AP: gearbox with input shaft - MI: geared motor with integral mounting - MU: geared motor with IEC motor, manufactured with universal mounting
Standard motor		- LS 56 to 71, 4 poles: 3-phase multivoltage 230/400 VY - 400 VΔ - single-phase 230 VΔ - LS and LSES 80 to 315, 4 poles: 3-phase multivoltage 230VΔ - 380VY - 400VY - 415VY 50 Hz - 460VY 60 Hz / 380VΔ - 400VΔ - 415VΔ - 690VY 50 Hz - 460VΔ 60 Hz - pressed steel fan cover, on request fitted with a drip cover for operation in vertical position (shaft facing down) - LS, LSES: terminal box in composite material (56 to 112) aluminium (≥ 132) fitted with screw-on plugs (without cable gland) - IP 55 standard protection
Brake motors		- FMD: idle command brake motor, IP55 (LS 56 to 71) - FFB: idle command brake motor, IP55 (LS 71 at 180, LSES 80 to 160) - FCPL: idle command brake motor, IP44 (LS 180 to 315)
Paint	Shade RAL 6000 (green)	- C3L (1 x acrylic polyurethane finish 50µm +/-20%)

## Fixing type, operating positions

### FIXING TYPES: S, SBS, SBD

**Standard position:** with the gearbox seen from face F, motor behind, face D on the ground.

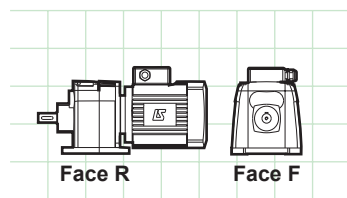

**S**

Foot mounted housing

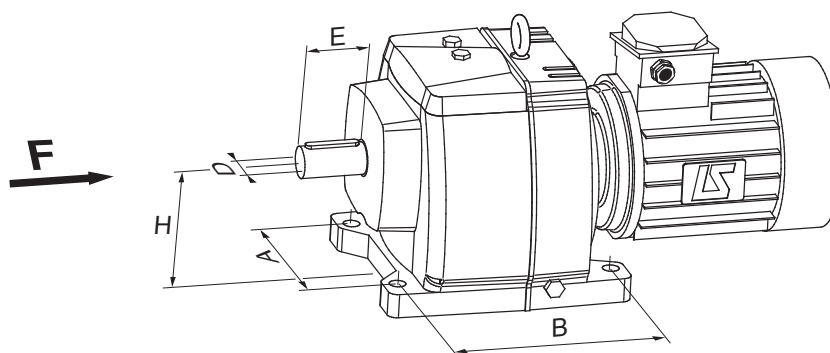

Dimensions in millimetres

1 stage gearbox						
Compabloc	ØD	E	A	B	H	kg
<b>Cb 3531</b>	45k6	90	260	160	160	41
<b>Cb 3431</b>	40k6	80	216	125	132	25
<b>Cb 3331</b>	35k6	70	190	100	112	15.5
<b>Cb 3231</b>	25j6	50	140	80	90	8.3
<b>Cb 3131</b>	20j6	40	120	75	80	6.9
<b>Cb 3031</b>	16j6	40	125	70	75	2.3

Multistage gearbox						
Compabloc	ØD	E	A	B	H	kg
<b>Cb 3833</b>	110m6	210	510	480	355	290
<b>Cb 3733</b>	90m6	170	420	390	315	192
<b>Cb 3633</b>	70m6	140	355	355	250	162
<b>Cb 3533</b>	60m6	120	280	280	225	90
<b>Cb 3433</b>	50k6	100	230	235	180	50
<b>Cb 3333</b>	40k6	80	170	240	140	30
<b>Cb 3233</b>	30j6	60	135	192	115	18.5
<b>Cb 3133</b>	25j6	50	110	165	90	13
<b>Cb 3033</b>	20j6	40	125	125	75	4.9
<b>Cb 3032</b>	20j6	40	125	105	75	4.8
<b>Cb 15--</b>	16j6	40	100	105	90	3.2

## Operating position

The absolute connection orientation (Terminal box: high, low, right, left, front, rear) depends on the operating position chosen. The relative orientation (0-90-180-270, trigonometric direction), which depends on the absolute position, is linked to the feet (actual or fictitious) for an observer, facing the gearbox.

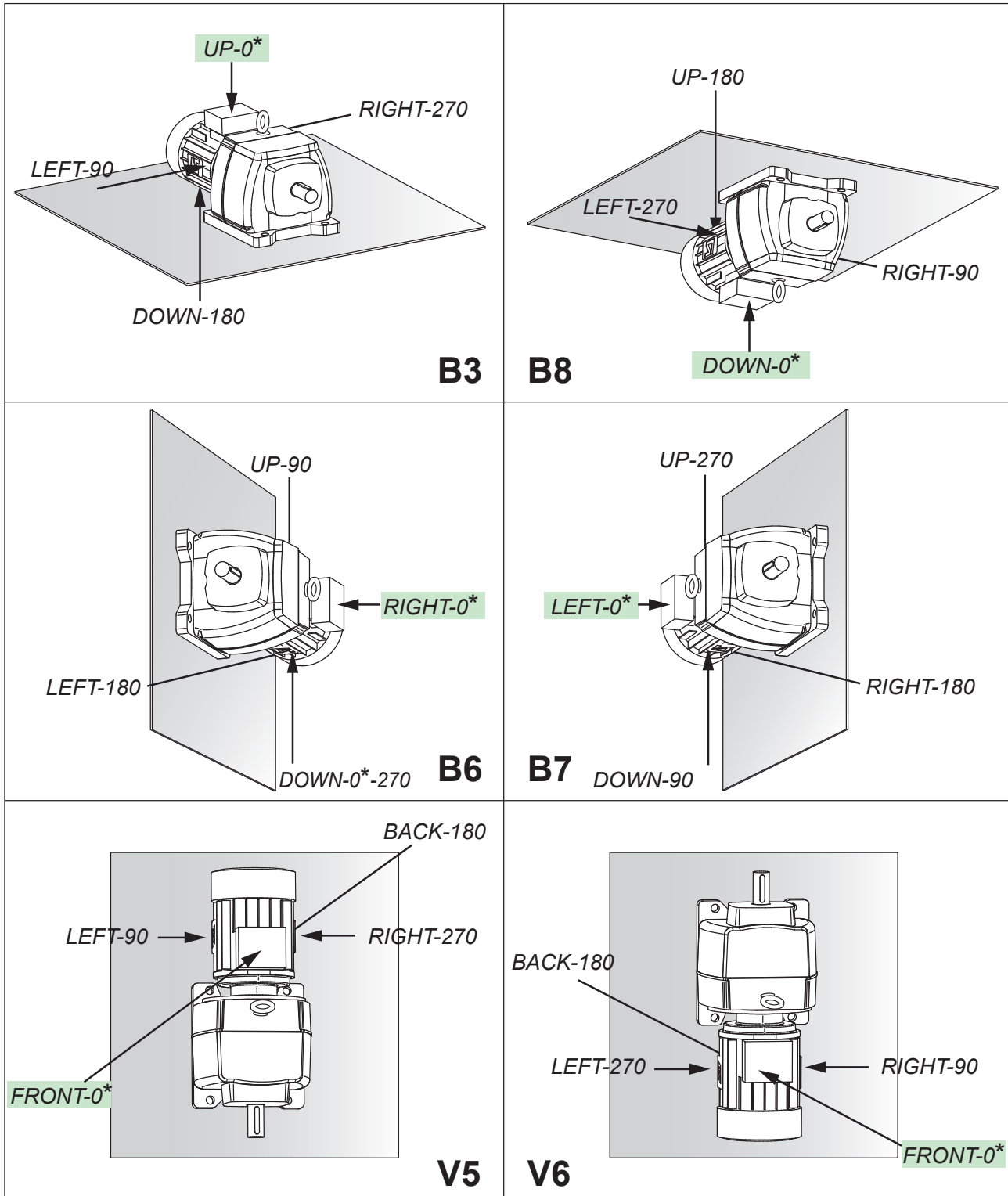

\*: Std terminal box

## Fixing type, operating positions

### FIXING TYPE: BS, BDN ..., BR, BT

Standard position: with the gearbox seen from face F, motor behind, face D on the ground.

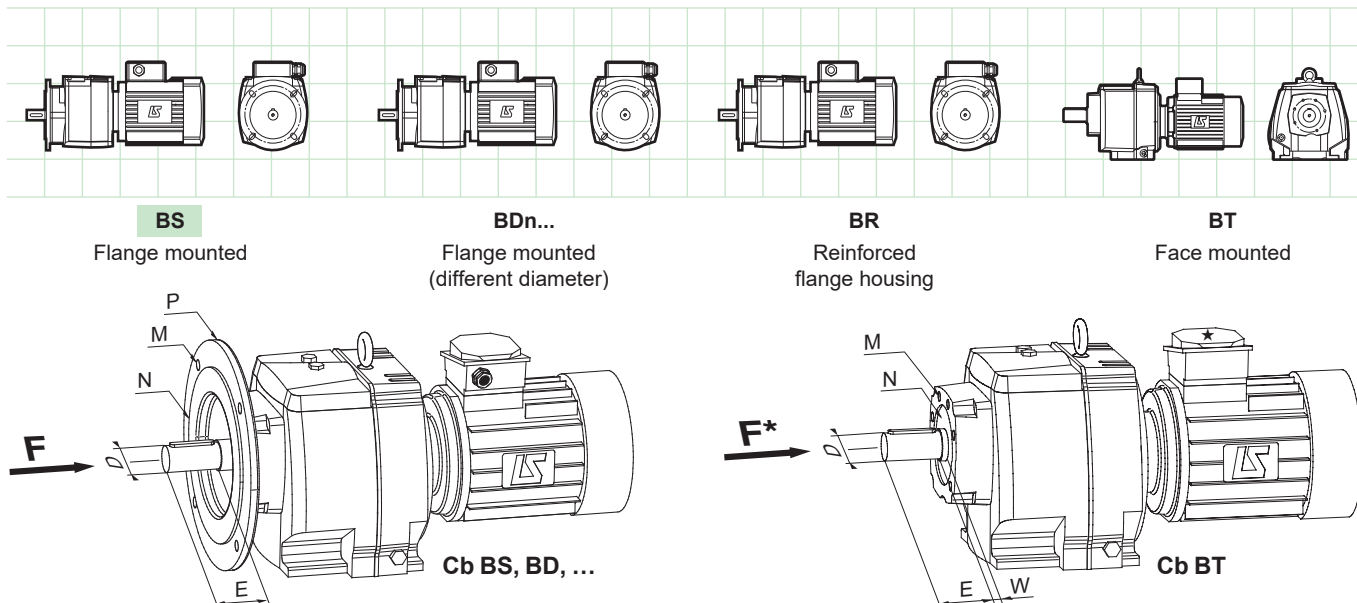

### GEARBOXES BS, BD, ...

Dimensions in millimetres

Compabloc	1 stage gearbox																	
	BS						BD1				BD2				BD3			
	∅D	E	∅M	∅N	∅P	kg	∅M	∅N	∅P	kg	∅M	∅N	∅P	kg	∅M	∅N	∅P	kg
<b>Cb 3531</b>	45k6	90	300	250	350	48	265	230	300	46	-	-	-	-	-	-	-	-
<b>Cb 3431</b>	40k6	80	265	230	300	31	215	180	250	30	-	-	-	-	-	-	-	-
<b>Cb 3331</b>	35k6	70	215	180	250	19	165	130	200	18	-	-	-	-	-	-	-	-
<b>Cb 3231</b>	25j6	50	165	130	200	10	130	110	160	9.5	-	-	-	-	-	-	-	-
<b>Cb 3131</b>	20j6	40	130	110	160	8.1	115	95	140	7.9	100	80	120	-	-	-	-	-
<b>Cb 3031</b>	16j6	40	115	95	140	2.5	100	80	120	2.5	130	110	160	2.5	165	130	200	2.4

Compabloc	Multistage gearbox																	
	BS						BD1				BD2				BD3			
	∅D	E	∅M	∅N	∅P	kg	∅M	∅N	∅P	kg	∅M	∅N	∅P	kg	∅M	∅N	∅P	kg
<b>Cb 3833</b>	110m6	210	600	550	660	352	500	450	550	328	-	-	-	-	-	-	-	-
<b>Cb 3733</b>	90m6	170	500	450	550	228	400	350	450	222	-	-	-	-	-	-	-	-
<b>Cb 3633</b>	70m6	140	500	450	550	196	400	350	450	190	-	-	-	-	-	-	-	-
<b>Cb 3533</b>	60m6	120	350	300	400	97	300	250	350	96	265	230	300	90	-	-	-	-
<b>Cb 3433</b>	50k6	100	300	250	350	56	265	230	300	55	215	180	250	54	-	-	-	-
<b>Cb 3333</b>	40k6	80	265	230	300	34	215	180	250	33	165	130	200	32.5	-	-	-	-
<b>Cb 3233</b>	30j6	60	215	180	250	18.8	165	130	200	18.7	130	110	160	18.6	-	-	-	-
<b>Cb 3133</b>	25j6	50	165	130	200	13.4	130	110	160	13.3	115	95	140	13.2	100	80	120	13.1
<b>Cb 3033</b>	20j6	40	115	95	140	4.9	100	80	120	4.5	130	110	160	4.9	165	130	200	5
<b>Cb 3032</b>	20j6	40	115	95	140	4.9	100	80	120	4.5	130	110	160	4.9	165	130	200	5
<b>Cb 15--</b>	16j6	40	100	80	120	2.9	85	70	105	2.8	115	95	140	3	-	-	-	-

### BT GEARBOX

Compabloc	1 stage gearbox					
	∅D	E	∅M	∅N	W	kg
<b>Cb 3531</b>	45k6	90	190	140	34	41
<b>Cb 3431</b>	40k6	80	152	130	28	25
<b>Cb 3331</b>	35k6	70	120	100	15	15.5
<b>Cb 3231</b>	25j6	50	83	70	15	8.3
<b>Cb 3131</b>	20j6	40	83	70	15	6.9
<b>Cb 3031</b>	16j6	40	100	60	12	2.3

Compabloc	Multistage gearbox					
	∅D	E	∅M	∅N	W	kg
<b>Cb 3833</b>	110m6	210	300	250	80	290
<b>Cb 3733</b>	90m6	170	230	180	80	192
<b>Cb 3633</b>	70m6	140	230	150	80	162
<b>Cb 3533</b>	60m6	120	190	140	34	86
<b>Cb 3433</b>	50k6	100	152	130	28	48
<b>Cb 3333</b>	40k6	80	123	100	23	30
<b>Cb 3233</b>	30j6	60	100	82	15	18.5
<b>Cb3133</b>	25j6	50	83	70	15	12.7
<b>Cb 3032-3033</b>	20j6	40	100	60	12	4.7
<b>Cb 3032-3033</b>	Option 25j6	40	100	60	12	4.8

## Operating position

The absolute connection orientation (Terminal box: high, low, right, left, front, rear) depends on the operating position chosen. The relative orientation (0-90-180-270, trigonometric direction), which depends on the absolute position, is linked to the feet (actual or fictitious) for an observer, facing the gearbox.

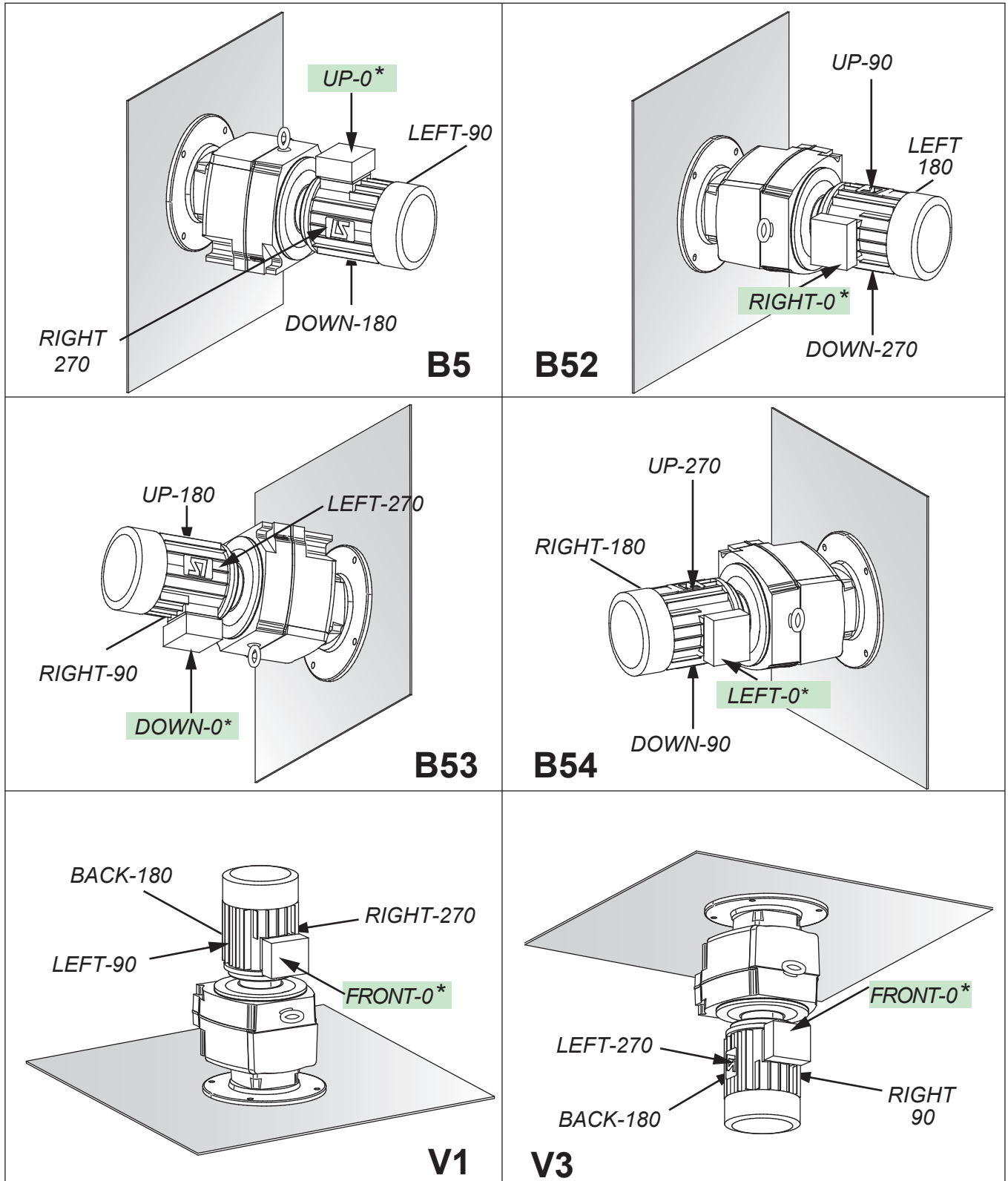

\*: Std terminal box



Selection  
Compabloc: Cb / AP

**SELECTING AN INPUT SHAFT (AP) GEARBOX**

You need to know:

- the duty factor
- the input and output speeds
- the input power or output torque
- the fixing and mounting position.

**1 - Choice of the duty factor K** Its value is determined by the application and the operating conditions. Refer to page 40 in the electromechanical engineering manual reference 5181.

**2 - Selection of the gearbox**

a - Calculate the reduction *i* such that

$$i = N_E / N_S$$

where  $N_E$  and  $N_S$  are the input and output speeds (in  $\text{min}^{-1}$ );

b - Calculate:

- the equivalent torque  $M_{eq}$ :

$$M_{eq} = M_S \times K$$

where  $M_S$  is the output torque (in N.m), K is the duty factor

- or the equivalent power  $P_{eq}$

$$P_{eq} = P \times K$$

where P is the input power (in kW);

c - Refer to the selection tables corresponding to the type of gearbox:

pages 14 and 15 and pages 16 and 17 for combined gearboxes. Each box in the table gives:

- the size of the gearbox
- the exact reduction
- the input power for  $K = 1$
- the rated output torque for  $K = 1$

Select the gearbox in the tables (pages 14 to 17), which has a torque equal or greater than the equivalent torque

(or a power equal or greater than the equivalent power) calculated above for the required, reduction ratio.

If the input speed is different from those given in the tables, select the gearbox size using the table with the closest input speed to that used for the output speed closest to that required.

Then choose the appropriate reduction ratio for this size of device.

**3 - Operating positions**

Feet: page 8

Flange: page 10

**4 - Verification of the radial force**

Refer to pages 43 to 45 in the document reference 5181.

If the radial force available on the output shaft is lower than that required by the application, restart the selection using a higher duty factor.

For gearboxes driven by the motor by means of a belt pulley system, refer to the tables in page 45 of the document reference 5181 to check the diameter of the pulley to install on the gearbox input shaft.

**5 - Choice of options**

Refer to the chapter “equipment and options” for any choice of standardized options. Cb 36 to 38 can be fitted with a non return device (backstop AD). In this event, indicate the rotation direction of the gearbox as seen from the output shaft side (page 150).

**6 - Commissioning, lubrication**

Refer to page 158

If in doubt concerning the choice or selection of a device, please do not

hesitate to contact your Leroy-Somer agent or distributor.

Example of selection

Driving a pump:

- power 14.7 kW at  $750 \text{ min}^{-1}$ ,
- output speed  $250 \text{ min}^{-1}$ ,
- operation: 3 hours per day with moderate overloads. Flange fixing, horizontal mounting with semi-elastic coupling.

1 - Duty factor  $K = 1$

2 - Selection:

a - reduction ratio:

$$i = 750 / 250 = 3$$

b - equivalent power: identical to the input power ( $K = 1$ ).

The following is found in the selection grid of page 15 for the closest reduction index: 3.18 one Cb 3431 for power immediately above 14.7 which is 15.3.

3 - Operating position: B5 (page 11).

4 - Fixing type: standard flange (page 10).

**Designation:**

**Cb 3431 3.18 BS S B5 AP**

i exact    Cb  
kW         $M_{nS}$

$N_S$ $\text{min}^{-1}$	$i_{aR}$	COMPABLOC																	
		15--	30--		31--		32--		33--		34--		35--	3633*		3733*		3833*	
423	3.55	3.63 0.7	3031 16	3.71 4.7	3133 112	3.43 3.6	3231 80	3.52 6.4	3331 146	3.6 13.6	3431 328	3.55 22.6	3531 539	3.64 97.2	3633 2401	3.52 193	3733 4607	3.49 319	3833 7550
476	3.15	3.24 0.8	3031 16	3.25 2.4	3131 50	3.09 4.0	3231 80	3.16 6.6	3331 135	3.18 15.3	3431 328	3.07 22.8	3531 471	3.21 96.0	3633 2092	3.08 218	3733 4566	3.18 275	3833 5929
536	2.8	2.75 0.9	3031 16	2.74 2.8	3131 50	2.72 4.6	3231 80	2.91 7.9	3331 148	2.83 17.1	3431 324	2.77 25.4	3531 472					2.88 312	3833 6095
600	2.5	2.55 1.0	3031 16	2.58 3.0	3131 50	2.55 4.9	3231 80	2.58 9.0	3331 150	2.54 18.4	3431 314	2.44 26.8	3531 439						

# Geared Motors 3000 Range - IMfinity®

## Compabloc

### Designation

### Compabloc: Cb / AP

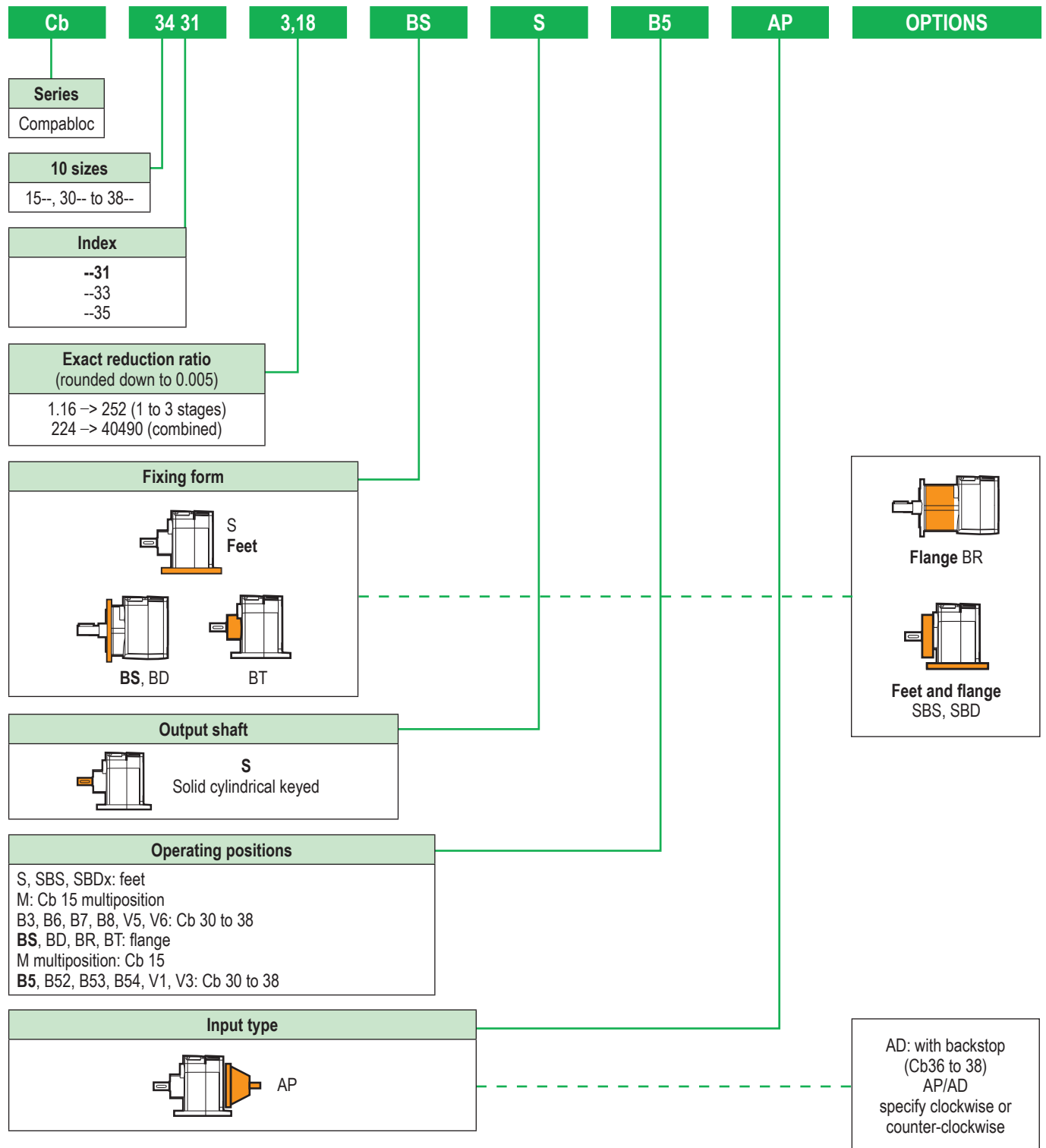

**Cb AP - 1500 min<sup>-1</sup> - kp = 1**

i exact   Cb  
kW        M<sub>nS</sub>

Rated capacities

N <sub>S</sub> min <sup>-1</sup>	i <sub>aR</sub>	COMPABLOC																				
		15--		30--		31--		32--		33--		34--		35--		3633*		3733*		3833*		
6.00	250																252	<b>3633</b>	244	<b>3733</b>		
																	2.5	4407	6.0	10098		
6.52	230																216	<b>3633</b>	217	<b>3733</b>	220	<b>3833</b>
																	3.0	4407	6.8	10098	10.0	15164
7.50	200			204	<b>3033</b>	200	<b>3133</b>	204	<b>3233</b>	200	<b>3333</b>	204	<b>3433</b>	201	<b>3533</b>	199	<b>3633</b>	198	<b>3733</b>	196	<b>3833</b>	
				0.07	90	0.16	204	0.35	456	0.66	835	1.16	1628	2.2	3090	3.2	4407	7.4	10098	11.3	15164	
8.33	180			181	<b>3033</b>	181	<b>3133</b>	174	<b>3233</b>	181	<b>3333</b>	172	<b>3433</b>	173	<b>3533</b>	173	<b>3633</b>	175	<b>3733</b>	184	<b>3833</b>	
				0.08	90	0.18	204	0.41	456	0.73	835	1.38	1624	2.6	3083	3.7	4407	8.4	10098	12.0	15164	
9.38	160	161	<b>1503</b>	161	<b>3033</b>	158	<b>3133</b>	159	<b>3233</b>	162	<b>3333</b>	155	<b>3433</b>	159	<b>3533</b>	153	<b>3633</b>	158	<b>3733</b>	164	<b>3833</b>	
		0.06	66	0.09	90	0.20	204	0.45	456	0.82	835	1.53	1622	2.8	3079	4.2	4407	9.3	10098	13.5	15164	
10.7	140	144	<b>1503</b>	146	<b>3033</b>	144	<b>3133</b>	144	<b>3233</b>	141	<b>3333</b>	140	<b>3433</b>	138	<b>3533</b>	137	<b>3633</b>	141	<b>3733</b>	146	<b>3833</b>	
		0.07	65	0.10	90	0.22	204	0.50	456	0.94	835	1.69	1620	3.2	3073	4.7	4402	10.4	10093	15.1	15164	
12.0	125	125	<b>1503</b>	130	<b>3033</b>	124	<b>3133</b>	123	<b>3233</b>	125	<b>3333</b>	129	<b>3433</b>	122	<b>3533</b>	122	<b>3633</b>	129	<b>3733</b>	130	<b>3833</b>	
		0.08	65	0.11	90	0.26	204	0.59	456	1.1	835	1.83	1618	3.7	3066	5.2	4390	11.4	10073	17.0	15124	
13.4	112	110	<b>1503</b>	115	<b>3033</b>	111	<b>3133</b>	109	<b>3233</b>	114	<b>3333</b>	111	<b>3433</b>	110	<b>3533</b>	112	<b>3633</b>	111	<b>3733</b>	115	<b>3833</b>	
		0.09	64	0.12	90	0.29	202	0.66	456	1.2	835	2.12	1614	4.1	3060	5.7	4381	13.2	10038	19.1	15082	
15.0	100	98.3	<b>1503</b>	102	<b>3033</b>	99.4	<b>3133</b>	98.2	<b>3233</b>	101	<b>3333</b>	104	<b>3433</b>	97.5	<b>3533</b>	96.6	<b>3633</b>	102	<b>3733</b>	103	<b>3833</b>	
		0.10	63	0.14	90	0.31	194	0.73	456	1.3	835	2.26	1612	4.6	3054	6.6	4367	14.3	10019	21.3	15042	
16.7	90	88.2	<b>1503</b>	91.1	<b>3033</b>	87	<b>3133</b>	86.5	<b>3233</b>	90.1	<b>3333</b>	90.7	<b>3433</b>	89.3	<b>3533</b>	87.3	<b>3633</b>	89.9	<b>3733</b>	92	<b>3833</b>	
		0.11	63	0.16	90	0.34	186	0.83	456	1.5	835	2.58	1608	5.0	3049	7.3	4357	16.2	9990	23.8	15001	
18.8	80	79.7	<b>1503</b>	81.3	<b>3033</b>	82.2	<b>3133</b>	77.9	<b>3233</b>	80.9	<b>3333</b>	80.1	<b>3433</b>	77.2	<b>3533</b>	76.9	<b>3633</b>	76.8	<b>3733</b>	81.5	<b>3833</b>	
		0.12	62	0.18	90	0.35	182	0.93	456	1.6	835	2.92	1605	5.7	3039	8.2	4344	18.7	9847	26.8	14960	
21.1	71	70.8	<b>1503</b>	69.1	<b>3033</b>	69.2	<b>3133</b>	68.6	<b>3233</b>	74.4	<b>3333</b>	71.4	<b>3433</b>	69.8	<b>3533</b>	70.8	<b>3633</b>	68.3	<b>3733</b>	71.7	<b>3833</b>	
		0.13	60	0.21	90	0.39	172	1.1	456	1.8	835	3.27	1601	6.1	2921	8.9	4336	20.0	9386	30.3	14912	
23.8	63	64.6	<b>1503</b>	64.1	<b>3033</b>	65.3	<b>3133</b>	64.2	<b>3233</b>	66.1	<b>3333</b>	63.9	<b>3433</b>	61.4	<b>3533</b>	63	<b>3633</b>	61.2	<b>3733</b>	63.1	<b>3833</b>	
		0.14	59	0.22	90	0.41	169	1.1	456	2.0	835	3.64	1598	6.6	2775	10.0	4324	21.4	8975	34.3	14865	
26.8	56	59.1	<b>1503</b>	55	<b>3033</b>	57.8	<b>3133</b>	55.7	<b>3233</b>	57.6	<b>3333</b>	54.7	<b>3433</b>	56.6	<b>3533</b>	56.2	<b>3633</b>	55.4	<b>3733</b>	55.7	<b>3833</b>	
		0.15	58	0.26	90	0.44	162	1.3	456	2.3	835	4.24	1592	6.9	2674	11.2	4312	22.6	8575	38.8	14818	
30.0	50	50.1	<b>1503</b>	49.2	<b>3033</b>	49.1	<b>3133</b>	50.2	<b>3233</b>	48.7	<b>3333</b>	50.3	<b>3433</b>	49.7	<b>3533</b>	50.4	<b>3633</b>	48.8	<b>3733</b>	50.5	<b>3833</b>	
		0.18	56	0.29	90	0.65	204	1.4	456	2.6	806	4.65	1589	8.9	3008	12.4	4301	24.3	8144	42.7	14783	
33.3	45	46.2	<b>1503</b>	45.4	<b>3032</b>	44.5	<b>3133</b>	43	<b>3233</b>	44	<b>3333</b>	42.5	<b>3433</b>	42.8	<b>3533</b>	42.8	<b>3633</b>	43.2	<b>3733</b>	44.1	<b>3833</b>	
		0.19	55	0.31	90	0.53	149	1.7	455	2.9	806	5.48	1583	10.3	2996	13.9	4045	26.1	7730	48.7	14731	
37.5	40	40.8	<b>1503</b>	40.3	<b>3032</b>	38.8	<b>3133</b>	39.2	<b>3233</b>	39.4	<b>3333</b>	38.2	<b>3433</b>	39.2	<b>3533</b>	39	<b>3633</b>	40.2	<b>3733</b>	39.4	<b>3833</b>	
		0.21	53	0.35	90	0.82	203	1.8	454	3.2	806	6.09	1578	11.2	2989	16.1	4275	27.8	7596	54.3	14688	
42.3	35.5	36.9	<b>1503</b>	35.7	<b>3032</b>	35.4	<b>3133</b>	35.5	<b>3233</b>	34.2	<b>3333</b>	34.6	<b>3433</b>	34.2	<b>3533</b>	34.5	<b>3633</b>	36	<b>3733</b>	35.1	<b>3833</b>	
		0.22	52	0.39	90	0.90	203	2.0	453	3.7	806	6.70	1574	12.8	2977	18.0	4218	32.6	7963	60.8	14645	
47.6	31.5	31.5	<b>1502</b>	32.5	<b>3032</b>	30.6	<b>3133</b>	30.3	<b>3233</b>	30.2	<b>3333</b>	31.9	<b>3433</b>	30.1	<b>3533</b>	31.1	<b>3633</b>	31.8	<b>3733</b>	31.6	<b>3833</b>	
		0.20	41	0.43	90	1.0	202	2.3	451	4.2	806	7.25	1570	14.5	2965	19.7	4160	39.9	8621	67.4	14604	
53.6	28	28.2	<b>1502</b>	28.8	<b>3032</b>	27.2	<b>3133</b>	26.9	<b>3233</b>	27.8	<b>3333</b>	27.4	<b>3433</b>	27.1	<b>3533</b>	27.7	<b>3633</b>	28.4	<b>3733</b>	27.7	<b>3833</b>	
		0.28	50	0.49	90	1.2	201	2.6	450	4.5	806	8.40	1563	16.1	2954	21.8	4099	45.6	8797	76.6	14553	
60.0	25	24.5	<b>1502</b>	25.6	<b>3032</b>	24.4	<b>3133</b>	24.2	<b>3233</b>	24.6	<b>3333</b>	25.5	<b>3433</b>	24.1	<b>3533</b>	25.5	<b>3633</b>	25.2	<b>3733</b>	24.5	<b>3833</b>	
		0.31	49	0.55	89	1.3	201	2.9	449	5.1	806	9.01	1560	18.0	2943	23.4	4055	50.5	8647	73.9	12298	
67.0	22.4	21.6	<b>1502</b>	22.8	<b>3032</b>	21.4	<b>3133</b>	21.3	<b>3233</b>	21.9	<b>3333</b>	22.4	<b>3433</b>	22.1	<b>3533</b>	21.9	<b>3633</b>	22.6	<b>3733</b>	21.9	<b>3833</b>	
		0.35	48	0.61	89	1.5	200	3.3	447	5.8	806	10.2	1553	19.5	2933	26.7	3976	55.5	8514	82.2	12220	
75.0	20	19.3	<b>1502</b>	20.2	<b>3032</b>	20.2	<b>3133</b>	19.2	<b>3233</b>	19.6	<b>3333</b>	19.8	<b>3433</b>	19.1	<b>3533</b>	20	<b>3633</b>	20.1	<b>3733</b>	19.5	<b>3833</b>	
		0.38	47	0.69	89	1.6	200	3.6	444	6.4	806	11.5	1547	21.3	2759	29.0	3932	61.4	8377	86.4	11441	
83.3	18	17.3	<b>1502</b>	18.1	<b>3032</b>	17	<b>3133</b>	16.9	<b>3233</b>	18.1	<b>3333</b>	17.6	<b>3433</b>	17.2	<b>3533</b>	17.7	<b>3633</b>	17.8	<b>3733</b>	17.4	<b>3833</b>	
		0.42	46	0.77	89	1.8	199	3.9	426	7.0	806	12.9	1540	24.8	2898	32.2	3872	68.2	8239	98.8	11675	

N<sub>S</sub>: output speed

i<sub>aR</sub>: reduction index

Cb36, Cb37, Cb38\*: check the gearbox thermal limit

M<sub>nS</sub>: rated output torque (Nm)

Selection  
Compabloc: Cb / AP

Cb AP - 1500 min<sup>-1</sup> - kp = 1

Rated capacities

i exact	Cb
kW	M <sub>nS</sub>

N <sub>S</sub> min <sup>-1</sup>	i <sub>aR</sub>	COMPABLOC																			
		15--		30--		31--		32--		33--		34--		35--		3633*		3733*		3833*	
93.8	16	15.6	1502	15.4	3032	16	3133	15.8	3233	16.1	3333	15.8	3433	15.2	3533	15.1	3633	15.7	3733	15.4	3833
		0.5	46	0.9	88	1.9	199	4.1	417	7.8	806	14.3	1534	27.0	2788	37.0	3797	75.9	8096	105	10994
107	14	13.9	1502	14.2	3032	14.2	3133	13.7	3233	14	3333	13.5	3433	14	3533	13.5	3633	13.8	3733	13.7	3833
		0.5	44	1.0	88	2.2	198	4.5	398	9.0	805	16.6	1524	28.5	2707	40.8	3743	84.9	7958	118	10977
125	12	12.7	1502	12.2	3032	12.4	3133	12	3233	12.7	3333	12.2	3433	12.4	3533	12.1	3633	12.2	3733	12.5	3833
		0.5	43	1.1	88	2.4	192	5.0	380	9.9	802	18.3	1518	31.5	2656	45.0	3694	94.5	7827	123	10439
136	11	11.6	1502	10.9	3032	10.9	3133	10.9	3233	11.1	3333	10.8	3433	11.1	3533	10.9	3633	11	3733	11	3833
		0.6	42	1.3	87	2.6	184	5.3	368	5.8	409	20.0	1470	33.6	2535	49.3	3650	103	7727	139	10404
150	10	9.81	1502	10.2	3032	9.67	3133	9.62	3233	9.95	3333	9.67	3433	9.94	3533	9.63	3633	9.64	3733	9.96	3833
		0.6	40	1.3	87	2.9	177	5.7	352	6.4	409	21.6	1416	36.9	2487	55.0	3596	116	7593	150	10153
167	9	9.07	1502	8.59	3032	8.57	3133	9.02	3233	9.16	3333	8.6	3433	9.07	3533	8.53	3633	8.62	3733	8.75	3833
		0.7	39	1.6	87	3.1	170	6.0	345	7.0	409	23.3	1359	39.1	2410	61.2	3546	128	7486	165	9817
188	8	7.99	1502	8.16	3032	8.28	3133	8.02	3233	8.14	3333	7.69	3433	7.92	3533	7.62	3633	7.68	3733	8.11	3833
		0.7	38	1.7	87	2.7	141	4.9	249	7.9	409	22.7	1184	42.8	2300	67.7	3500	142	7378	170	9353
211	7.1	7.23	1502	7.38	3032	7.34	3133	6.96	3233	7.09	3333	6.86	3433	7.18	3533	7.15	3633	6.9	3733	6.95	3833
		0.8	36	1.8	86	3.0	141	5.6	249	9.0	409	20.0	934	28.5	1390	71.6	3475	155	7283	200	9415
238	6.3	6.4	3031	6.42	3133	6.1	3233	6.41	3333	6.21	3433	6.38	3533	6.15	3633	6.05	3733	6.33	3833		
		0.4	16	3.4	141	6.4	249	10.0	409	21.4	902	31.5	1364	78.6	3283	174	7167	214	9215		
268	5.6	5.82	3031	5.65	3133	5.51	3233	5.59	3333	5.48	3433	5.7	3533	5.56	3633	5.63	3733	5.55	3833		
		0.4	16	3.8	139	7.1	249	11.4	409	20.9	777	33.6	1301	85.1	3211	124	4733	252	9512		
300	5	5.17	3031	4.99	3133	4.88	3233	5.06	3333	4.91	3433	5.1	3533	4.91	3633	4.91	3733	5.01	3833		
		0.5	16	4.0	127	8.0	249	12.6	409	24.6	821	44.2	1530	93.6	3119	141	4699	274	9326		
333	4.5	4.58	3031	4.43	3133	4.57	3233	4.59	3333	4.37	3433	4.66	3533	4.34	3633	4.39	3733	4.4	3833		
		0.5	16	4.1	116	8.5	249	13.9	409	24.3	722	46.4	1467	103	3029	157	4670	303	9062		
375	4	4.08	3031	3.91	3133	3.87	3233	3.98	3333	3.91	3433	4.07	3533	3.88	3633	3.91	3733	4.08	3833		
		0.6	16	4.6	115	10.1	249	16.1	409	22.7	602	49.7	1372	104	2728	175	4638	306	8464		
423	3.55	3.63	3031	3.71	3133	3.43	3231	3.52	3331	3.6	3431	3.55	3531	3.64	3633	3.52	3733	3.49	3833		
		0.7	16	4.7	112	3.6	80	6.4	146	13.6	328	22.6	539	97.2	2401	193	4607	319	7550		
476	3.15	3.24	3031	3.25	3131	3.09	3231	3.16	3331	3.18	3431	3.07	3531	3.21	3633	3.08	3733	3.18	3833		
		0.8	16	2.4	50	4.0	80	6.6	135	15.3	328	22.8	471	96.0	2092	218	4566	275	5929		
536	2.8	2.75	3031	2.74	3131	2.72	3231	2.91	3331	2.83	3431	2.77	3531					2.88	3833		
		0.9	16	2.8	50	4.6	80	7.9	148	17.1	324	25.4	472					312	6095		
600	2.5	2.55	3031	2.58	3131	2.55	3231	2.58	3331	2.54	3431	2.44	3531								
		1.0	16	3.0	50	4.9	80	9.0	150	18.4	314	26.8	439								
670	2.24	2.19	3031	2.29	3131	2.21	3231	2.25	3331	2.17	3431	2.25	3531								
		1.1	16	3.4	50	5.6	80	9.0	130	20.5	299	27.7	419								
750	2	1.96	3031	2	3131	1.94	3231	2.04	3331	1.97	3431	2	3531								
		1.3	16	3.7	48	6.4	80	9.4	124	21.8	289	29.0	390								
833	1.8	1.83	3031	1.76	3131	1.75	3231	1.77	3331	1.74	3431	1.79	3531								
		1.4	16	3.9	44	6.9	78	8.9	102	21.3	249	30.1	363								
938	1.6	1.54	3031	1.56	3131	1.55	3231	1.61	3331	1.56	3431	1.6	3531								
		1.6	16	4.0	41	7.5	75	8.9	92	25.0	263	31.4	337								
1071	1.4	1.46	3031	1.38	3131	1.45	3231	1.46	3331	1.38	3431	1.46	3531								
		1.7	16	4.2	37	7.3	68	9.0	85	24.9	231	32.3	317								
1200	1.25	1.32	3031	1.22	3131	1.23	3231	1.26	3331	1.24	3431	1.28	3531								
		1.7	16	4.5	35	0.5	62	0.8	36	23.1	192	33.5	288								
1339	1.12			1.16	3131																
				4.6	35																

N<sub>S</sub>: output speed  
i<sub>aR</sub>: reduction index  
Cb36, Cb37, Cb38\*: check the gearbox thermal limit  
M<sub>nS</sub>: rated output torque (Nm)

Selection  
Compabloc: Cb / AP

**Cb AP - 1500 min<sup>-1</sup> - kp = 1**

Rated capacities; combined gearboxes

i exact	Cb
kW	M <sub>nS</sub>

N <sub>S</sub> min <sup>-1</sup>	i <sub>aR</sub>	COMPABLOC													
		3235		3335		3435		3535		3635*		3735*		3835*	
0.06	25000					25000	<b>3535</b>	24400	<b>3635</b>	24300	<b>3735</b>	26500	<b>3835</b>		
						<b>0.02</b>	3121	<b>0.03</b>	4407	<b>0.06</b>	10098	<b>0.08</b>	15164		
0.07	22400					22300	<b>3535</b>	21700	<b>3635</b>	21600	<b>3735</b>	22300	<b>3835</b>		
						<b>0.02</b>	3121	<b>0.03</b>	4407	<b>0.07</b>	10098	<b>0.10</b>	15164		
0.08	20000					20000	<b>3535</b>	19500	<b>3635</b>	19400	<b>3735</b>	20100	<b>3835</b>		
						<b>0.02</b>	3121	<b>0.03</b>	4407	<b>0.07</b>	10098	<b>0.11</b>	15164		
0.08	18000					17500	<b>3535</b>	17200	<b>3635</b>	18300	<b>3735</b>	18200	<b>3835</b>		
						<b>0.03</b>	3121	<b>0.04</b>	4407	<b>0.08</b>	10098	<b>0.12</b>	15164		
0.09	16000			16000	<b>3435</b>	16600	<b>3535</b>	15500	<b>3635</b>	15700	<b>3735</b>	16800	<b>3835</b>		
				<b>0.01</b>	1627	<b>0.03</b>	3121	<b>0.04</b>	4407	<b>0.09</b>	10098	<b>0.13</b>	15164		
0.11	14000			14500	<b>3435</b>	13900	<b>3535</b>	14400	<b>3635</b>	14300	<b>3735</b>	14600	<b>3835</b>		
				<b>0.02</b>	1627	<b>0.03</b>	3121	<b>0.04</b>	4407	<b>0.10</b>	10098	<b>0.15</b>	15164		
0.12	12500			12700	<b>3435</b>	13100	<b>3535</b>	12400	<b>3635</b>	13000	<b>3735</b>	12300	<b>3835</b>		
				<b>0.02</b>	1627	<b>0.03</b>	3121	<b>0.05</b>	4407	<b>0.11</b>	10098	<b>0.17</b>	15164		
0.13	11200			11500	<b>3435</b>	11600	<b>3535</b>	11300	<b>3635</b>	11100	<b>3735</b>	11100	<b>3835</b>		
				<b>0.02</b>	1627	<b>0.04</b>	3121	<b>0.05</b>	4407	<b>0.13</b>	10098	<b>0.19</b>	15164		
0.15	10000			9970	<b>3435</b>	10200	<b>3535</b>	10200	<b>3635</b>	9830	<b>3735</b>	10100	<b>3835</b>		
				<b>0.02</b>	1627	<b>0.04</b>	3121	<b>0.06</b>	4407	<b>0.14</b>	10098	<b>0.21</b>	15164		
0.17	9000			8890	<b>3435</b>	8970	<b>3535</b>	8710	<b>3635</b>	8830	<b>3735</b>	9270	<b>3835</b>		
				<b>0.03</b>	1627	<b>0.05</b>	3121	<b>0.07</b>	4407	<b>0.16</b>	10098	<b>0.23</b>	15164		
0.2	8000	7910	<b>3235</b>	8210	<b>3335</b>	7620	<b>3435</b>	7810	<b>3535</b>	7740	<b>3635</b>	7780	<b>3735</b>	7970	<b>3835</b>
		<b>0.01</b>	456	<b>0.02</b>	835	<b>0.03</b>	1639	<b>0.06</b>	3114	<b>0.08</b>	4407	<b>0.18</b>	10098	<b>0.27</b>	15164
0.2	7100	7030	<b>3235</b>	7300	<b>3335</b>	6900	<b>3435</b>	7080	<b>3535</b>	6960	<b>3635</b>	7000	<b>3735</b>	7420	<b>3835</b>
		<b>0.01</b>	456	<b>0.02</b>	835	<b>0.03</b>	1639	<b>0.06</b>	3114	<b>0.09</b>	4407	<b>0.20</b>	10098	<b>0.29</b>	15164
0.2	6300	6230	<b>3235</b>	6470	<b>3335</b>	6020	<b>3435</b>	6170	<b>3535</b>	6130	<b>3635</b>	6170	<b>3735</b>	6500	<b>3835</b>
		<b>0.01</b>	456	<b>0.02</b>	835	<b>0.04</b>	1639	<b>0.07</b>	3114	<b>0.10</b>	4407	<b>0.23</b>	10098	<b>0.33</b>	15164
0.3	5600	5670	<b>3235</b>	5880	<b>3335</b>	5480	<b>3435</b>	5620	<b>3535</b>	5520	<b>3635</b>	5770	<b>3735</b>	5740	<b>3835</b>
		<b>0.01</b>	456	<b>0.02</b>	835	<b>0.04</b>	1639	<b>0.08</b>	3114	<b>0.11</b>	4407	<b>0.24</b>	10098	<b>0.37</b>	15164
0.3	5000	5030	<b>3235</b>	5220	<b>3335</b>	4740	<b>3435</b>	4850	<b>3535</b>	4860	<b>3635</b>	5010	<b>3735</b>	5120	<b>3835</b>
		<b>0.01</b>	456	<b>0.03</b>	835	<b>0.05</b>	1639	<b>0.09</b>	3114	<b>0.13</b>	4407	<b>0.28</b>	10098	<b>0.41</b>	15164
0.3	4500	4460	<b>3235</b>	4630	<b>3335</b>	4220	<b>3435</b>	4330	<b>3535</b>	4550	<b>3635</b>	4600	<b>3735</b>	4580	<b>3835</b>
		<b>0.02</b>	456	<b>0.03</b>	835	<b>0.06</b>	1639	<b>0.10</b>	3114	<b>0.14</b>	4407	<b>0.30</b>	9692	<b>0.46</b>	15164
0.4	4000	3970	<b>3235</b>	4120	<b>3335</b>	3780	<b>3435</b>	3880	<b>3535</b>	3950	<b>3635</b>	3940	<b>3735</b>	3980	<b>3835</b>
		<b>0.02</b>	456	<b>0.03</b>	835	<b>0.06</b>	1639	<b>0.11</b>	3114	<b>0.16</b>	4407	<b>0.35</b>	9692	<b>0.52</b>	14769
0.4	3550	3530	<b>3235</b>	3670	<b>3335</b>	3310	<b>3435</b>	3390	<b>3535</b>	3610	<b>3635</b>	3590	<b>3735</b>	3360	<b>3835</b>
		<b>0.02</b>	456	<b>0.04</b>	835	<b>0.07</b>	1639	<b>0.13</b>	3114	<b>0.17</b>	4288	<b>0.38</b>	9692	<b>0.62</b>	14769
0.5	3150	3150	<b>3235</b>	3270	<b>3335</b>	3130	<b>3435</b>	3210	<b>3535</b>	3090	<b>3635</b>	3250	<b>3735</b>	3030	<b>3835</b>
		<b>0.02</b>	456	<b>0.04</b>	835	<b>0.07</b>	1639	<b>0.14</b>	3114	<b>0.20</b>	4288	<b>0.42</b>	9692	<b>0.69</b>	14769
0.5	2800	2680	<b>3235</b>	2780	<b>3335</b>	2640	<b>3435</b>	2700	<b>3535</b>	2820	<b>3635</b>	2770	<b>3735</b>	2740	<b>3835</b>
		<b>0.03</b>	456	<b>0.05</b>	835	<b>0.09</b>	1639	<b>0.16</b>	3114	<b>0.21</b>	4288	<b>0.49</b>	9692	<b>0.76</b>	14769
0.6	2500	2480	<b>3235</b>	2580	<b>3335</b>	2480	<b>3435</b>	2550	<b>3535</b>	2560	<b>3635</b>	2470	<b>3735</b>	2530	<b>3835</b>
		<b>0.03</b>	456	<b>0.05</b>	835	<b>0.09</b>	1639	<b>0.17</b>	3114	<b>0.24</b>	4288	<b>0.55</b>	9692	<b>0.83</b>	14769

N<sub>S</sub>: output speed

i<sub>aR</sub>: reduction index

Cb36, Cb37, Cb38\*: check the gearbox thermal limit

M<sub>nS</sub>: rated output torque (Nm)

Selection  
Compabloc: Cb / AP

**Cb AP - 1500 min<sup>-1</sup> - kp = 1**

Rated capacities; combined gearboxes

i exact	Cb
kW	M <sub>nS</sub>

N <sub>S</sub> min <sup>-1</sup>	i <sub>aR</sub>	COMPABLOC													
		3235		3335		3435		3535		3635*		3735*		3835*	
0.7	2240	2130	<b>3235</b>	2210	<b>3335</b>	2200	<b>3435</b>	2260	<b>3535</b>	2180	<b>3635</b>	2220	<b>3735</b>	2170	<b>3835</b>
		<b>0.03</b>	456	<b>0.06</b>	835	<b>0.11</b>	1639	<b>0.20</b>	3114	<b>0.28</b>	4288	<b>0.62</b>	9692	<b>0.96</b>	14769
0.8	2000	1910	<b>3235</b>	1980	<b>3335</b>	1930	<b>3435</b>	1970	<b>3535</b>	1940	<b>3635</b>	1950	<b>3735</b>	2020	<b>3835</b>
		<b>0.04</b>	456	<b>0.07</b>	835	<b>0.12</b>	1639	<b>0.23</b>	3114	<b>0.31</b>	4288	<b>0.70</b>	9692	<b>1.0</b>	14769
0.8	1800	1780	<b>3235</b>	1850	<b>3335</b>	1700	<b>3435</b>	1740	<b>3535</b>	1740	<b>3635</b>	1760	<b>3735</b>	1770	<b>3835</b>
		<b>0.04</b>	456	<b>0.07</b>	835	<b>0.14</b>	1639	<b>0.26</b>	3114	<b>0.35</b>	4288	<b>0.78</b>	9692	<b>1.2</b>	14769
0.9	1600	1500	<b>3235</b>	1560	<b>3335</b>	1570	<b>3435</b>	1540	<b>3535</b>	1530	<b>3635</b>	1550	<b>3735</b>	1570	<b>3835</b>
		<b>0.05</b>	456	<b>0.09</b>	835	<b>0.15</b>	1605	<b>0.29</b>	3114	<b>0.40</b>	4288	<b>0.88</b>	9692	<b>1.3</b>	14769
1.1	1400	1370	<b>3235</b>	1370	<b>3335</b>	1420	<b>3435</b>	1440	<b>3535</b>	1380	<b>3635</b>	1450	<b>3735</b>	1390	<b>3835</b>
		<b>0.05</b>	456	<b>0.09</b>	806	<b>0.16</b>	1605	<b>0.30</b>	3074	<b>0.44</b>	4288	<b>0.94</b>	9692	<b>1.5</b>	14769
1.2	1250	1220	<b>3235</b>	1220	<b>3335</b>	1240	<b>3435</b>	1300	<b>3535</b>	1220	<b>3635</b>	1260	<b>3735</b>	1250	<b>3835</b>
		<b>0.06</b>	456	<b>0.11</b>	806	<b>0.19</b>	1605	<b>0.34</b>	3074	<b>0.50</b>	4288	<b>1.1</b>	9692	<b>1.7</b>	14769
1.3	1120	1080	<b>3235</b>	1080	<b>3335</b>	1130	<b>3435</b>	1140	<b>3535</b>	1140	<b>3635</b>	1130	<b>3735</b>	1070	<b>3835</b>
		<b>0.07</b>	456	<b>0.12</b>	806	<b>0.20</b>	1605	<b>0.38</b>	3074	<b>0.53</b>	4288	<b>1.22</b>	9692	<b>2.0</b>	14769
1.5	1000	984	<b>3235</b>	982	<b>3335</b>	975	<b>3435</b>	1040	<b>3535</b>	988	<b>3635</b>	970	<b>3735</b>	983	<b>3835</b>
		<b>0.07</b>	456	<b>0.13</b>	806	<b>0.24</b>	1605	<b>0.42</b>	3074	<b>0.61</b>	4288	<b>1.4</b>	9692	<b>2.1</b>	14769
1.7	900	874	<b>3235</b>	872	<b>3335</b>	869	<b>3435</b>	894	<b>3535</b>	890	<b>3635</b>	885	<b>3735</b>	829	<b>3835</b>
		<b>0.08</b>	456	<b>0.15</b>	806	<b>0.27</b>	1605	<b>0.49</b>	3074	<b>0.69</b>	4288	<b>1.6</b>	9692	<b>2.5</b>	14769
2	800	775	<b>3235</b>	774	<b>3335</b>	779	<b>3435</b>	797	<b>3535</b>	762	<b>3635</b>	801	<b>3735</b>	747	<b>3835</b>
		<b>0.09</b>	456	<b>0.17</b>	806	<b>0.30</b>	1605	<b>0.55</b>	3074	<b>0.80</b>	4288	<b>1.7</b>	9692	<b>2.8</b>	14769
2	710	690	<b>3235</b>	688	<b>3335</b>	681	<b>3435</b>	714	<b>3535</b>	695	<b>3635</b>	684	<b>3735</b>	676	<b>3835</b>
		<b>0.11</b>	456	<b>0.19</b>	806	<b>0.34</b>	1605	<b>0.61</b>	3074	<b>0.88</b>	4288	<b>2.0</b>	9692	<b>3.1</b>	14769
2	630	613	<b>3235</b>	612	<b>3335</b>	644	<b>3435</b>	625	<b>3535</b>	630	<b>3635</b>	608	<b>3735</b>	623	<b>3835</b>
		<b>0.12</b>	456	<b>0.21</b>	806	<b>0.36</b>	1605	<b>0.70</b>	3074	<b>0.97</b>	4288	<b>2.3</b>	9692	<b>3.4</b>	14769
3	560	547	<b>3235</b>	546	<b>3335</b>	543	<b>3435</b>	591	<b>3535</b>	537	<b>3635</b>	546	<b>3735</b>	535	<b>3835</b>
		<b>0.13</b>	456	<b>0.24</b>	806	<b>0.43</b>	1605	<b>0.74</b>	3074	<b>1.1</b>	4288	<b>2.5</b>	9692	<b>3.9</b>	14769
3	500	465	<b>3235</b>	464	<b>3335</b>	511	<b>3435</b>	498	<b>3535</b>	477	<b>3635</b>	481	<b>3735</b>	499	<b>3835</b>
		<b>0.16</b>	456	<b>0.28</b>	806	<b>0.45</b>	1605	<b>0.88</b>	3074	<b>1.3</b>	4288	<b>2.9</b>	9692	<b>4.2</b>	14769
3	450	431	<b>3235</b>	431	<b>3335</b>	453	<b>3435</b>	469	<b>3535</b>	429	<b>3635</b>	433	<b>3735</b>	437	<b>3835</b>
		<b>0.17</b>	456	<b>0.30</b>	806	<b>0.51</b>	1605	<b>0.94</b>	3074	<b>1.4</b>	4288	<b>3.2</b>	9692	<b>4.8</b>	14769
4	400	371	<b>3235</b>	370	<b>3335</b>	396	<b>3435</b>	416	<b>3535</b>	378	<b>3635</b>	381	<b>3735</b>	386	<b>3835</b>
		<b>0.20</b>	456	<b>0.35</b>	806	<b>0.58</b>	1605	<b>1.1</b>	3074	<b>1.6</b>	4288	<b>3.6</b>	9692	<b>5.5</b>	14769
4	355	331	<b>3235</b>	330	<b>3335</b>	349	<b>3435</b>	364	<b>3535</b>	340	<b>3635</b>	357	<b>3735</b>	344	<b>3835</b>
		<b>0.22</b>	456	<b>0.39</b>	806	<b>0.66</b>	1605	<b>1.2</b>	3074	<b>1.8</b>	4288	<b>3.9</b>	9692	<b>6.1</b>	14769
5	315	309	<b>3235</b>	308	<b>3335</b>	308	<b>3435</b>	320	<b>3535</b>	300	<b>3635</b>	310	<b>3735</b>	308	<b>3835</b>
		<b>0.24</b>	456	<b>0.42</b>	806	<b>0.75</b>	1605	<b>1.4</b>	3074	<b>2.0</b>	4288	<b>4.5</b>	9692	<b>6.9</b>	14769
5	280	260	<b>3235</b>	260	<b>3335</b>	273	<b>3435</b>	283	<b>3535</b>	280	<b>3635</b>	272	<b>3735</b>	264	<b>3835</b>
		<b>0.28</b>	456	<b>0.50</b>	806	<b>0.85</b>	1605	<b>1.55</b>	3074	<b>2.2</b>	4288	<b>5.1</b>	9692	<b>8.0</b>	14769
6	250	247	<b>3235</b>	247	<b>3335</b>	242	<b>3435</b>	251	<b>3535</b>					239	<b>3835</b>
		<b>0.30</b>	456	<b>0.52</b>	806	<b>0.96</b>	1605	<b>1.7</b>	3074					<b>8.8</b>	14769
7	224	224	<b>3235</b>	223	<b>3335</b>	229	<b>3435</b>	222	<b>3535</b>						
		<b>0.33</b>	456	<b>0.58</b>	806	<b>1.0</b>	1605	<b>2.0</b>	3074						

N<sub>S</sub>: output speed

i<sub>aR</sub>: reduction index

Cb36, Cb37, Cb38\*: check the gearbox thermal limit

M<sub>nS</sub>: rated output torque (Nm)

Input shaft AP dimensions

Dimensions in millimetres

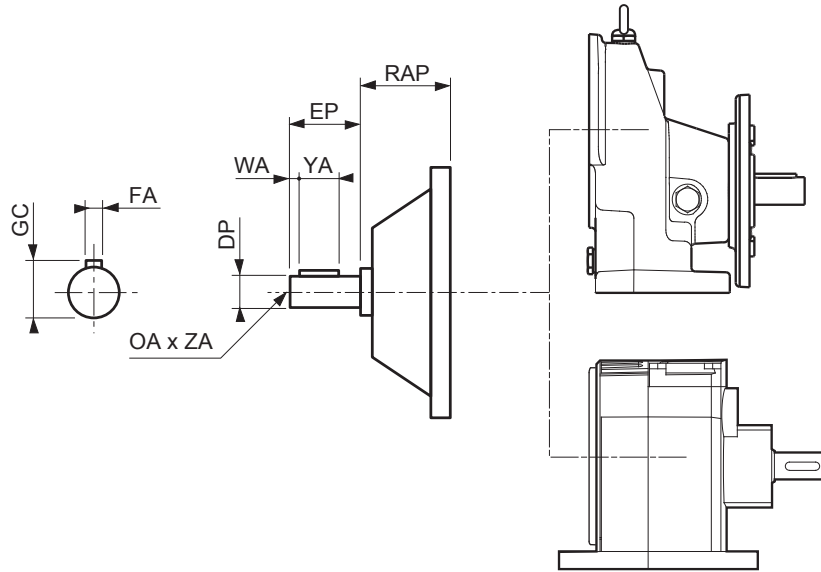

Type	AP								kg
	ØDP	EP	FA	GC	OAxZA	RAP	WA	YA	
Cb38--	55k6	110	16	59	M20x42	48.5	10	90	32
Cb37--	48k6	110	14	51.5	M16x36	51	10	90	27
Cb36--	48k6	110	14	51.5	M16x36	51	10	90	27
Cb35--	38j6	80	10	41	M12x28	129.5	8	63	14
Cb34--	28j6	60	8	31	M10x22	138.5	5	50	5
Cb33--	28j6	60	8	31	M10x22	69	5	50	5
Cb32--	24j6	50	8	27	M8x19	73	4.5	40	1.5
Cb31--	24j6	50	8	27	M8x19	73	4.5	40	1.5
Cb30--	14j6	30	5	16	M4x14	69	3	20	1.3
Cb15--	11j7	23	4	12.5	M4x10	50.5	-	20	0.3



## SELECTING A GEARED MOTOR

Use the following procedure to select the geared motor:

### 1 - Determination of the necessary power or torque

You need to know:

- $P_{UE}$ : rated input power necessary for the application
- $N_S$ : gearbox output speed in  $\text{min}^{-1}$ .

The following selection tables are organized:

- by power for output speeds from 0.35 to over  $1200 \text{ min}^{-1}$ ; please call for lower speeds
- by increasing  $K_p$ , by reduction index section

The relationship between input power, output speed and output torque is given by the formula:

$$M_S = P_E \times 9.550 \times \eta / N_S$$

where  $\eta$  represents the mechanical efficiency of the gearbox (page 7 and 51 of document reference 5181).

### 2 - Determination of the necessary duty factor K

This is determined according to 3 criteria:

- a - Operating time (h/d)
- b - Frequency of starts Z
- c - Ratio of the load inertia to the motor inertia: curves I, II, III (page 40 of the document reference 5181).

### 3 - Determination of the type of geared motor

- Select the power required for the application in the tables pages 22 to 111.
- Choose the output speed corresponding to that of the application.
- Then choose the geared motor with a duty factor greater than that required by the application.

### 4 - Verification

- a - Radial force exerted on the slow speed shaft by the load (pages 44 and 45 of the document reference 5181).
- b - Verification of the chosen geared motor.

In the selection tables (pages 22 to 111), check that the value of radial force permissible by the geared motor exceeds the radial force applied by the load (page 44 of the document reference 5181).

### 5 - Mounting form

Refer to page 8 for the definition of feet fixing, and page 10 for the definition of flange fixing.

### 6 - Operating position

Refer to page 9 for the definition of the feet fixing operating positions, and page 11 for the those of flange fixing.

#### Example

Application data:

- Driving a conveyor
- $P_{UE}$ : 2.2 kW
- $N_{US}$ :  $34 \text{ min}^{-1}$
- Daily operating time: 8 h/d
- Frequency of starts of the application: 300 s/h
- Moment of inertia of the application reduced to the motor shaft:  $0.0064 \text{ kgm}^2$
- Motor moment of inertia:  $0.00567 \text{ kgm}^2$

Determining the duty factor:

- $FJ = J_{C/M} / J_M$   
 $= 0.0064 / 0.00567 = 1.13$
- The application class is II (reading on curve II of the graph page 40 in the document reference 5181)
- The graph of the duty factor K indicates the following for 8 h/d and 300 s/h:  
--->  $K = 1.4$

### Selection of the geared motor

- a - Fixed speed
  - Find the selection tables for  $P_{UE} = 2.2 \text{ kW}$
  - Find the geared motor output speed  $N_S$  closest to  $44 \text{ min}^{-1}$  (page 63)
  - Select the geared motor with a duty factor greater than that required by the application.
  - ---> Selection of geared motor Cb 3333,  $i = 34.2$ ,  $K_p = 1.67$  (extract on next page)
  - Finally, check that the radial and axial force values of the geared motor are greater than the forces exerted by the load.

### b - Variable speed

When used in variable speed with separate drive, the gearbox input speed shall not exceed  $3,000 \text{ min}^{-1}$ .

Select in the 87 Hz tables the power equivalent to 2.2 kW - 50 Hz,  $42 \text{ min}^{-1}$  (page 53).

Take the 1.5 kW motor developing 2.61 kW at 87 Hz.

Search for the speed required 43.8 in Cb 3333 with  $i: 57.6$  and  $K_p = 1.54$  (extract next page).

## Selection

### Compabloc: Cb / LS, LSES motors

#### SELECTING A FIXED SPEED GEARED MOTOR

- Search the selection tables corresponding to  $P_{uE} = 2.2 \text{ kW}$
- Search the geared motor output speed  $N_S$  closest to  $44 \text{ min}^{-1}$
- Geared motor selection with a duty factor greater than that required by the application.
- ---> Selection of the geared motor Cb 3333,  $i = 34.2$ ,  $K_p = 1.67$
- Finally, check that the values of the radial and axial forces ( $F_R E/2$ ) of the geared motor exceed the stress applied by the load.

LS, LSES 1500 min <sup>-1</sup> - 50 Hz		Cb - Gearbox					LS, LSES 2600 min <sup>-1</sup> - 87 Hz	
$N_S$ (min <sup>-1</sup> )	$K_p$	Cb / MI-MU	i	M (Nm)	$F_R E/2$ (N)	Dim. MI <—> page	$N_S$ (min <sup>-1</sup> )	$K_p$
<b>2.2 kW - 50 Hz</b>		LSES 100 LR IFT/IE3 LS 100 L FFB2 IFT/NIE - LSES 100 LR FFB2 IFT/IE3					<b>3.83 kW - 87 Hz*</b>	
42.0	1.67	3333	34.2	482	10,242	135	74.2	1.71

#### SELECTING A VARIABLE SPEED GEARED MOTOR CENTRALISED PILOT CONTROL WITH DRIVE



When used in variable speed with separate drive, the gearbox input speed shall not exceed  $3,000 \text{ min}^{-1}$

Select in the 87 Hz tables the power equivalent to 2.2 kW - 50 Hz,  $42 \text{ min}^{-1}$

Take the 1.5 kW motor developing 2.61 kW at 87 Hz

Search for the speed required 43.8 in Cb 3333 with  $i: 57.6$  and  $K_p = 1.54$

LS, LSES 1500 min <sup>-1</sup> - 50 Hz		Cb - Gearbox					LS, LSES 2600 min <sup>-1</sup> - 87 Hz	
$N_S$ (min <sup>-1</sup> )	$K_p$	Cb / MI-MU	i	M (Nm)	$F_R E/2$ (N)	Dim. MI <—> page	$N_S$ (min <sup>-1</sup> )	$K_p$
<b>1.5 kW - 50 Hz</b>		LSES 90 LU IFT/IE3 LS 90 L FFB2 IFT/NIE - LSES 90 LU FFB2 IFT/IE3					<b>2.61 kW - 87 Hz*</b>	
24.8	1.52	3333	57.6	548	9,613	135	43.8	1.54

#### AVAILABILITY

Product quality and energy performance have now become major criteria in user choices, but pointless when the products available do not meet requirements.

The table abstract below is an overview of the ranges part of the Express Availability program.

To know your product's availability, refer to the detailed charter accessible at: <http://lrsm.co/dispofr>

	Motors and geared motors	Range	*Lead times (with a selection of options)
General use	IMfinity IE2 - IP55 induction motors	0.12 to 0.55 kW	D to D+10
	IMfinity IE3 - IP55 induction motors	0.75 to 355 kW	D to D+10
	LS non-IE single speed induction motors	0.09 to 3 kW	D to D+2
	Single phase motors	0.06 to 1.5 kW	-
	Brake motors	0.25 to 45 kW	D+1 to D+10
	Helical geared motors	30 to 14,500 Nm	D+5 to D+10
	Motors with ID300 built-in drive	0.25 to 7,5 kW	D+5 to D+10

\*Lead times in working days for an order received by the factory on day D before noon.

See details in page 162.

# Geared Motors 3000 Range - IMfinity®

## Compabloc

### Designation

### Compabloc: Cb / LS, LSES motors

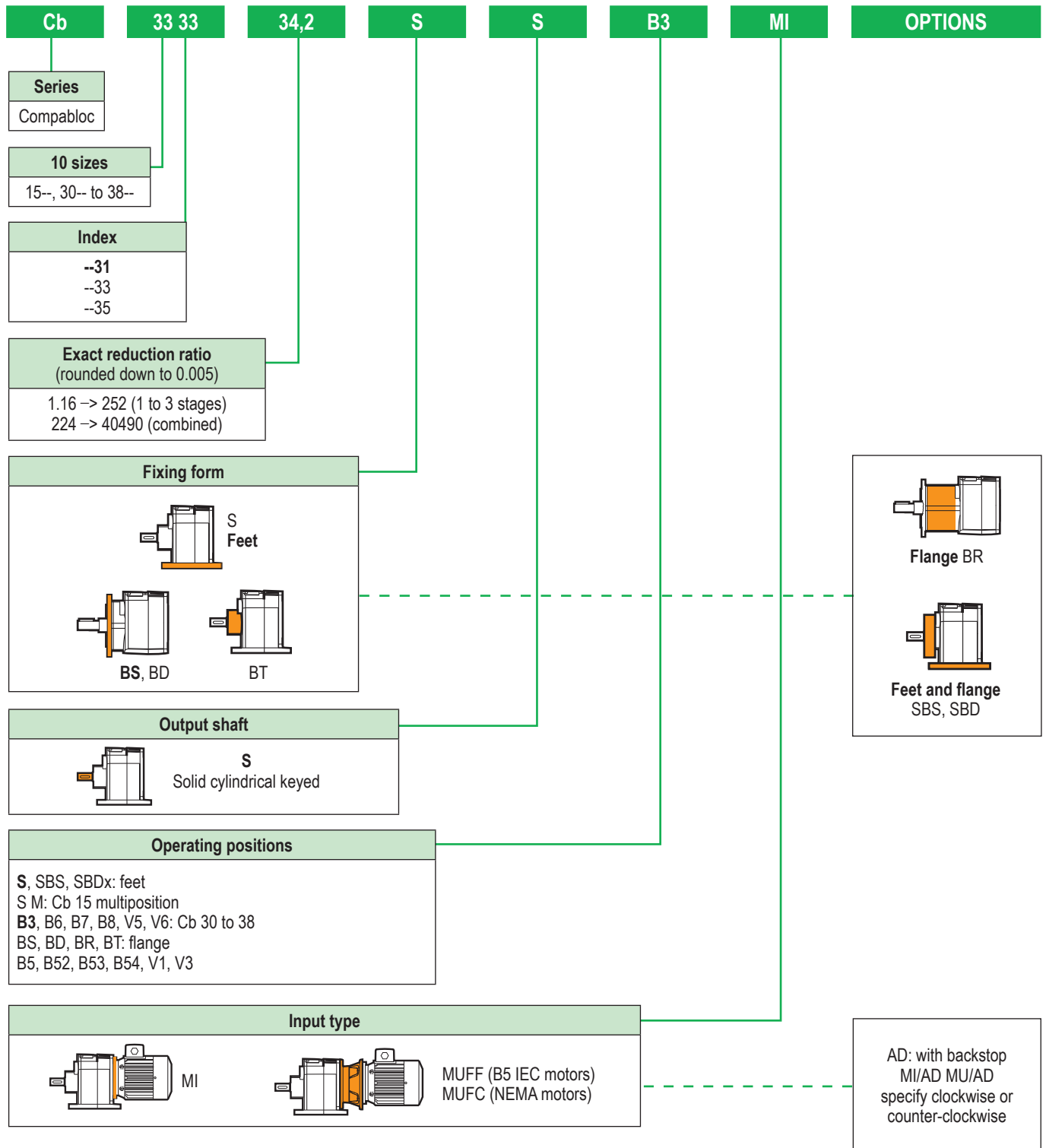

LS, LSES 1500 min <sup>-1</sup> - 50 Hz		Cb - Gearbox					LS, LSES 2600 min <sup>-1</sup> - 87 Hz	
N <sub>s</sub> (min <sup>-1</sup> )	Kp	Cb / MI-MU	i	M (Nm)	F <sub>R</sub> E/2 (N)	Dim. MI <—> page	N <sub>s</sub> (min <sup>-1</sup> )	Kp
<b>0.06 kW - 50 Hz</b>		<i>Single phase LS 56 M-P<sup>1</sup> - Three-phase LS 56 M<sup>1</sup></i> <i>Single phase LS 56 M-P FMD<sup>1</sup> - Three-phase LS 56 M FMD<sup>1</sup></i>						
6.76	1.44	3033	204	63	3.717	129		
7.61	1.62	3033	181	56	3.856	129		
8.58	1.36	1503	161	49	1.580	125		
8.58	1.83	3033	161	49	3.982	129		
9.61	1.51	1503	144	43	1.710	125		
9.44	2.01	3033	146	45	4.072	129		
11.0	1.72	1503	125	38	1.710	125		
10.6	2.26	3033	130	40	4.174	129		
12.5	1.92	1503	110	33	1.800	125		
12.0	2.55	3033	115	35	4.264	129		
14.0	2.14	1503	98.3	30	1.800	125		
13.5	2.87	3033	102	31	4.344	129		
15.6	2.36	1503	88.2	27	1.800	125		
15.2	3.23	3033	91.1	28	4.414	129		
17.3	2.58	1503	79.7	24	1.820	125		
17.0	3.62	3033	81.3	25	4.476	129		
19.5	2.85	1503	70.8	21	1.820	125		
20.0	4	3033	69.1	21	4.552	129		
21.4	3.06	1503	64.6	20	1.820	125		
21.5	5	3033	64.1	20	4.584	129		
23.3	3.27	1503	59.1	18	1.820	125		
25.1	5	3033	55	17	4.641	129		
27.6	3.77	1503	50.1	15	1.820	125		
28.1	6	3033	49.2	15	4.678	129		
29.9	3.98	1503	46.2	14	1.820	125		
30.1	6	3033	45.9	14	4.698	129		
30.4	6	3032	45.4	14	4.467	127		
33.9	4	1503	40.8	12	1.820	125		
34.2	7	3032	40.3	13	4.472	127		
35.7	8	3033	38.7	12	4.744	129		
37.4	5	1503	36.9	11	1.820	125		
38.6	8	3032	35.7	11	4.477	127		
43.7	4	1502	31.5	10	1.900	125		
42.5	9	3032	32.5	10	4.480	127		
49.0	6	1502	28.2	9	1.900	125		
47.8	10	3032	28.8	9	4.437	127		
56.2	7	1502	24.5	8	1.900	125		
53.9	11	3032	25.6	8	4.266	127		
63.8	7	1502	21.6	7	1.900	125		
60.6	13	3032	22.8	7	4.107	127		
71.6	8	1502	19.3	6	1.900	125		
68.2	14	3032	20.2	6	3.953	127		
79.8	9	1502	17.3	5	1.900	125		
76.4	16	3032	18.1	6	3.804	127		
88.3	10	1502	15.6	5	1.900	125		
89.9	19	3032	15.4	5	3.607	127		
99.4	10	1502	13.9	4	1.900	125		
96.9	20	3032	14.2	4	3.522	127		
109	11	1502	12.7	4	1.802	125		
113	23	3032	12.2	4	3.347	127		
119	12	1502	11.6	4	1.802	125		
126	26	3032	10.9	3	3.228	127		
141	13	1502	9.81	3	1.802	125		
135	28	3032	10.2	3	3.154	127		
152	14	1502	9.07	3	1.613	125		
161	33	3032	8.59	3	2.978	127		
170	6	3031	8.13	3	1.922	113		
173	16	1502	7.99	2	1.613	125		
191	7	3031	7.22	2	1.866	113		
191	16	1502	7.23	2	1.613	125		
216	8	3031	6.4	2	1.791	113		
237	9	3031	5.82	2	1.733	113		
267	10	3031	5.17	2	1.664	113		
301	11	3031	4.58	1	1.618	113		
338	13	3031	4.08	1	1.556	113		
381	14	3031	3.63	1	1.495	113		
427	16	3031	3.24	1	1.439	113		
502	19	3031	2.75	1	1.362	113		
541	20	3031	2.55	1	1.328	113		
630	23	3031	2.19	1	1.261	113		
705	26	3031	1.96	1	1.213	113		
756	28	3031	1.83	1	1.185	113		
897	33	3031	1.54	0.5	1.116	113		
944	35	3031	1.46	0.5	1.097	113		
1043	39	3031	1.32	0.4	1.060	113		

<sup>1</sup> motor not concerned by the IE

LS, LSES 1500 min <sup>-1</sup> - 50 Hz		Cb - Gearbox					LS, LSES 2600 min <sup>-1</sup> - 87 Hz	
N <sub>s</sub> (min <sup>-1</sup> )	Kp	Cb / MI-MU	i	M (Nm)	F <sub>R</sub> E/2 (N)	Dim. MI <—> page	N <sub>s</sub> (min <sup>-1</sup> )	Kp
<b>0.09 kW - 50 Hz</b>		Single phase LS 63 M-P <sup>1</sup> - Three-phase LS 56 M <sup>1</sup> Single phase LS 63 M-P FMD <sup>1</sup> - Three-phase LS 56 M FMD <sup>1</sup>						
6.86	0.89	3033	204	102	2.958	129		
7.72	1.00	3033	181	90	3.176	129		
8.70	0.83	1503	161	79	1.500	125		
8.71	1.13	3033	161	80	3.376	129		
9.75	0.92	1503	144	71	1.500	125		
9.58	1.24	3033	146	73	3.519	129		
11.2	1.05	1503	125	62	1.500	125		
10.8	1.40	3033	130	65	3.680	129		
12.7	1.18	1503	110	54	1.580	125		
12.2	1.58	3033	115	57	3.824	129		
14.2	1.31	1503	98.3	48	1.580	125		
13.7	1.77	3033	102	51	3.951	129		
15.9	1.45	1503	88.2	44	1.710	125		
15.4	1.99	3033	91.1	45	4.064	129		
17.6	1.58	1503	79.7	39	1.710	125		
17.2	2.23	3033	81.3	40	4.162	129		
19.8	1.74	1503	70.8	35	1.710	125		
20.3	2.63	3033	69.1	34	4.284	129		
21.7	1.87	1503	64.6	32	1.800	125		
21.9	2.83	3033	64.1	32	4.335	129		
23.7	2.00	1503	59.1	29	1.800	125		
25.4	3.30	3033	55	27	4.426	129		
28.0	2.30	1503	50.1	25	1.820	125		
28.5	3.69	3033	49.2	24	4.486	129		
30.3	2.43	1503	46.2	23	1.820	125		
30.5	3.95	3033	45.9	23	4.519	129		
30.9	3.95	3032	45.4	23	4.437	127		
34.4	2.68	1503	40.8	20	1.820	125		
34.7	4	3032	40.3	20	4.446	127		
36.2	5	3033	38.7	19	4.593	129		
38.0	2.88	1503	36.9	18	1.820	125		
38.1	5	3033	36.7	18	4.612	129		
39.2	5	3032	35.7	18	4.454	127		
44.4	2.60	1502	31.5	16	1.900	125		
42.1	5	3033	33.2	17	4.648	129		
43.1	5	3032	32.5	16	4.460	127		
49.7	3.56	1502	28.2	14	1.900	125		
48.5	6	3032	28.8	15	4.385	127		
57.1	3.99	1502	24.5	12	1.900	125		
54.7	7	3032	25.6	13	4.220	127		
64.7	4	1502	21.6	11	1.900	125		
61.5	8	3032	22.8	11	4.066	127		
72.6	5	1502	19.3	10	1.900	125		
69.2	9	3032	20.2	10	3.913	127		
80.9	5	1502	17.3	9	1.900	125		
77.5	10	3032	18.1	9	3.771	127		
89.6	6	1502	15.6	8	1.900	125		
91.2	11	3032	15.4	8	3.575	127		
101	6	1502	13.9	7	1.802	125		
98.3	12	3032	14.2	7	3.490	127		
111	7	1502	12.7	6	1.802	125		
114	14	3032	12.2	6	3.321	127		
121	7	1502	11.6	6	1.802	125		
128	16	3032	10.9	6	3.197	127		
143	8	1502	9.81	5	1.802	125		
137	17	3032	10.2	5	3.129	127		
154	9	1502	9.07	5	1.613	125		
163	20	3032	8.59	4	2.959	127		
172	3.87	3031	8.13	4	1.891	113		
175	10	1502	7.99	4	1.613	125		
172	21	3032	8.16	4	2.908	127		
194	4	3031	7.22	4	1.815	113		
194	10	1502	7.23	4	1.613	125		
190	23	3032	7.38	4	2.812	127		
219	5	3031	6.4	3	1.761	113		
241	5	3031	5.82	3	1.704	113		
271	6	3031	5.17	3	1.635	113		
305	7	3031	4.58	2	1.589	113		
343	8	3031	4.08	2	1.527	113		
386	9	3031	3.63	2	1.467	113		
433	10	3031	3.24	2	1.411	113		
509	11	3031	2.75	1	1.355	113		
549	12	3031	2.55	1	1.321	113		
639	14	3031	2.19	1	1.255	113		
716	16	3031	1.96	1	1.208	113		
767	17	3031	1.83	0.9	1.180	113		
910	20	3031	1.54	0.8	1.113	113		
958	22	3031	1.46	0.7	1.094	113		
1059	24	3031	1.32	0.7	1.058	113		

<sup>1</sup> motor not concerned by the IE

LS, LSES 1500 min <sup>-1</sup> - 50 Hz		Cb - Gearbox					LS, LSES 2600 min <sup>-1</sup> - 87 Hz	
N <sub>s</sub> (min <sup>-1</sup> )	Kp	Cb / MI-MU	i	M (Nm)	F <sub>R</sub> E/2 (N)	Dim. MI <—> page	N <sub>s</sub> (min <sup>-1</sup> )	Kp
<b>0.12 kW - 50 Hz</b>		<i>Single phase LS 63 M-P<sup>1</sup> - Three-phase LSES 63 M IFT/IE2</i> <i>Single phase LS 63 M-P FMD<sup>1</sup> - Three-phase LS 63 M FMD<sup>1</sup></i>						
8.58	0.80	3033	161	114	2,732	129		
9.44	0.88	3033	146	103	2,929	129		
10.6	0.99	3033	130	92	3,152	129		
12.5	0.83	1503	110	77	1,500	125		
12.0	1.11	3033	115	81	3,353	129		
14.0	0.92	1503	98.3	69	1,500	125		
13.5	1.25	3033	102	72	3,529	129		
15.6	1.02	1503	88.2	62	1,500	125		
15.2	1.41	3033	91.1	64	3,687	129		
17.3	1.11	1503	79.7	56	1,580	125		
17.0	1.57	3033	81.3	57	3,824	129		
19.5	1.23	1503	70.8	50	1,580	125		
20.0	1.85	3033	69.1	49	3,995	129		
21.4	1.32	1503	64.6	45	1,580	125		
21.5	2.00	3033	64.1	45	4,066	129		
23.3	1.41	1503	59.1	41	1,710	125		
25.1	2.33	3033	55	39	4,195	129		
27.6	1.63	1503	50.1	35	1,710	125		
28.1	2.60	3033	49.2	35	4,279	129		
29.9	1.72	1503	46.2	32	1,800	125		
30.1	2.79	3033	45.9	32	4,325	129		
30.4	2.79	3032	45.4	32	4,399	127		
33.9	1.89	1503	40.8	29	1,800	125		
34.2	3.13	3032	40.3	29	4,414	127		
35.7	3.30	3033	38.7	27	4,429	129		
37.4	2.03	1503	36.9	26	1,820	125		
37.6	3.47	3033	36.7	26	4,457	129		
38.6	3.53	3032	35.7	25	4,427	127		
43.7	1.83	1502	31.5	22	1,900	125		
41.5	3.82	3033	33.2	23	4,507	129		
42.5	3.88	3032	32.5	23	4,436	127		
49.0	2.51	1502	28.2	20	1,900	125		
47.8	4	3032	28.8	21	4,375	127		
56.2	2.80	1502	24.5	17	1,900	125		
53.9	5	3032	25.6	18	4,215	127		
63.8	3.14	1502	21.6	15	1,900	125		
60.6	6	3032	22.8	16	4,060	127		
71.6	3.47	1502	19.3	14	1,900	125		
68.2	6	3032	20.2	14	3,912	127		
79.8	3.79	1502	17.3	12	1,900	125		
76.4	7	3032	18.1	13	3,769	127		
88.3	4	1502	15.6	11	1,900	125		
89.9	8	3032	15.4	11	3,577	127		
99.4	5	1502	13.9	10	1,900	125		
96.9	9	3032	14.2	10	3,491	127		
109	5	1502	12.7	9	1,802	125		
113	10	3032	12.2	9	3,321	127		
119	5	1502	11.6	8	1,802	125		
126	11	3032	10.9	8	3,202	127		
141	6	1502	9.81	7	1,802	125		
135	12	3032	10.2	7	3,134	127		
152	6	1502	9.07	6	1,613	125		
161	14	3032	8.59	6	2,963	127		
170	2.73	3031	8.13	6	1,859	113		
173	7	1502	7.99	6	1,613	125		
169	15	3032	8.16	6	2,912	127		
191	3.07	3031	7.22	5	1,804	113		
191	7	1502	7.23	5	1,613	125		
187	16	3032	7.38	5	2,821	127		
216	3.47	3031	6.4	5	1,728	113		
237	3.82	3031	5.82	4	1,692	113		
267	4	3031	5.17	4	1,623	113		
301	5	3031	4.58	3	1,577	113		
338	5	3031	4.08	3	1,514	113		
381	6	3031	3.63	3	1,454	113		
427	7	3031	3.24	2	1,418	113		
502	8	3031	2.75	2	1,341	113		
541	9	3031	2.55	2	1,307	113		
630	10	3031	2.19	2	1,240	113		
705	11	3031	1.96	1	1,213	113		
756	12	3031	1.83	1	1,185	113		
897	14	3031	1.54	1	1,119	113		
944	15	3031	1.46	1	1,099	113		
1043	17	3031	1.32	1	1,062	113		

<sup>1</sup> motor not concerned by the IE

LS, LSES 1500 min <sup>-1</sup> - 50 Hz		Cb - Gearbox					LS, LSES 2600 min <sup>-1</sup> - 87 Hz	
N <sub>s</sub> (min <sup>-1</sup> )	K <sub>p</sub>	Cb / MI-MU	i	M (Nm)	F <sub>R</sub> E/2 (N)	Dim. MI < — > page	N <sub>s</sub> (min <sup>-1</sup> )	K <sub>p</sub>
<b>0.18 kW - 50 Hz</b>		<i>Single phase LS 71 L-P<sup>1</sup> - Three-phase LSES 63 M IFT/IE2</i>						
		<i>Single phase LS 71 L-P FMD<sup>1</sup> - Three-phase LS 63 M FMD<sup>1</sup></i>						
13.6	0.80	3033	102	112	2,756	129		
15.3	0.91	3033	91.1	100	2,994	129		
17.1	1.01	3033	81.3	89	3,202	129		
19.6	0.79	1503	70.8	77	1,500	125		
20.1	1.19	3033	69.1	76	3,462	129		
21.5	0.85	1503	64.6	70	1,500	125		
21.7	1.29	3033	64.1	70	3,570	129		
23.5	0.91	1503	59.1	65	1,500	125		
25.3	1.50	3033	55	60	3,765	129		
27.8	1.04	1503	50.1	55	1,580	125		
28.3	1.68	3033	49.2	54	3,894	129		
30.1	1.10	1503	46.2	50	1,580	125		
30.3	1.80	3033	45.9	50	3,965	129		
30.6	1.80	3032	45.4	50	4,313	127		
34.1	1.21	1503	40.8	44	1,710	125		
34.5	2.02	3032	40.3	45	4,342	127		
36.0	2.13	3033	38.7	42	4,124	129		
37.7	1.31	1503	36.9	40	1,710	125		
37.9	2.24	3033	36.7	40	4,167	129		
38.9	2.27	3032	35.7	40	4,366	127		
44.1	1.18	1502	31.5	35	1,800	125		
41.8	2.46	3033	33.2	36	4,244	129		
42.8	2.50	3032	32.5	36	4,383	127		
49.4	1.61	1502	28.2	31	1,800	125		
48.2	2.81	3032	28.8	32	4,308	127		
56.7	1.80	1502	24.5	27	1,800	125		
54.3	3.16	3032	25.6	28	4,154	127		
64.2	2.01	1502	21.6	24	1,900	125		
61.1	3.54	3032	22.8	25	4,005	127		
72.1	2.23	1502	19.3	21	1,900	125		
68.7	3.97	3032	20.2	22	3,861	127		
80.4	2.44	1502	17.3	19	1,900	125		
77.0	4	3032	18.1	20	3,724	127		
88.9	2.65	1502	15.6	17	1,900	125		
90.5	5	3032	15.4	17	3,537	127		
100	2.89	1502	13.9	15	1,802	125		
97.6	6	3032	14.2	16	3,452	127		
110	3.09	1502	12.7	14	1,802	125		
114	6	3032	12.2	14	3,288	127		
120	3.27	1502	11.6	13	1,802	125		
127	7	3032	10.9	12	3,174	127		
142	3.69	1502	9.81	11	1,802	125		
136	8	3032	10.2	11	3,105	127		
153	3.9	1502	9.07	10	1,613	125		
162	9	3032	8.59	10	2,935	127		
171	1.76	3031	8.13	9	1,791	113		
174	4	1502	7.99	9	1,613	125		
170	10	3032	8.16	9	2,889	127		
192	1.98	3031	7.22	8	1,736	113		
192	5	1502	7.23	8	1,613	125		
188	11	3032	7.38	8	2,798	127		
217	2.23	3031	6.4	7	1,682	113		
239	2.46	3031	5.82	7	1,625	113		
269	2.77	3031	5.17	6	1,577	113		
303	3.12	3031	4.58	5	1,531	113		
341	3.51	3031	4.08	5	1,468	113		
383	3.95	3031	3.63	4	1,429	113		
430	4	3031	3.24	4	1,373	113		
505	5	3031	2.75	3	1,317	113		
545	6	3031	2.55	3	1,283	113		
635	7	3031	2.19	2	1,237	113		
710	7	3031	1.96	2	1,190	113		
761	8	3031	1.83	2	1,162	113		
904	9	3031	1.54	2	1,094	113		
951	10	3031	1.46	2	1,076	113		
1051	11	3031	1.32	1	1,059	113		

<sup>1</sup> motor not concerned by the IE



LS, LSES 1500 min <sup>-1</sup> - 50 Hz		Cb - Gearbox					LS, LSES 2600 min <sup>-1</sup> - 87 Hz	
N <sub>s</sub> (min <sup>-1</sup> )	Kp	Cb / MI-MU	i	M (Nm)	F <sub>R</sub> E/2 (N)	Dim. MI <—> page	N <sub>s</sub> (min <sup>-1</sup> )	Kp
<b>0.25 kW - 50 Hz</b>		<i>Single phase LS 71 L-P<sup>1</sup>* - Three-phase LSES 71 M IFT/IE2 Single phase LS 71 L-P FMD<sup>1</sup>* - Three-phase LS 71 M FFB<sup>1</sup></i>						
0.16	0.79	3735	8830	12841	18,855	147		
0.18	0.89	3735	7780	11304	22,478	147		
0.20	0.99	3735	7000	10178	25,133	147		
0.23	1.13	3735	6170	8968	27,985	147		
0.25	1.20	3735	5770	8393	29,342	147		
0.28	1.39	3735	5010	7281	31,962	147		
0.31	1.43	3735	4600	6757	33,197	147		
0.36	1.67	3735	3940	5786	35,485	147		
0.39	0.81	3635	3610	5308	22,316	147		
0.40	1.84	3735	3590	5277	36,686	147		
0.46	0.94	3635	3090	4546	24,460	147		
0.44	2.03	3735	3250	4780	37,856	147		
0.51	1.03	3635	2820	4145	25,586	147		
0.51	2.38	3735	2770	4078	39,511	147		
0.56	0.82	3535	2550	3782	9,725	147		
0.56	1.14	3635	2560	3755	26,682	147		
0.58	2.67	3735	2470	3625	40,580	147		
0.63	0.93	3535	2260	3352	12,440	147		
0.65	1.34	3635	2180	3204	28,233	147		
0.64	2.97	3735	2220	3258	41,445	147		
0.72	1.06	3535	1970	2933	15,085	147		
0.74	1.51	3635	1940	2848	29,234	147		
0.73	3.38	3735	1950	2868	42,364	147		
0.82	1.21	3535	1740	2581	17,308	147		
0.82	1.68	3635	1740	2560	30,045	147		
0.81	3.75	3735	1760	2582	43,037	147		
0.93	1.90	3635	1530	2253	30,906	147		
0.92	4.26	3735	1550	2275	43,761	147		
0.99	1.44	3535	1440	2136	20,118	147		
1.03	2.11	3635	1380	2029	31,537	147		
0.98	5	3735	1450	2129	44,105	147		
1.15	0.86	3435	1240	1860	4,959	147		
1.09	1.59	3535	1300	1936	21,381	147		
1.17	2.40	3635	1220	1788	32,216	147		
1.13	5	3735	1260	1847	44,770	147		
1.26	0.95	3435	1130	1694	7,214	147		
1.25	1.82	3535	1140	1688	22,947	147		
1.25	2.56	3635	1140	1673	32,538	147		
1.26	5.76	3735	1130	1683	45,158	147		
1.46	1.10	3435	975	1463	10,113	147		
1.38	2.00	3535	1040	1537	23,900	147		
1.44	2.95	3635	988	1451	33,161	147		
1.47	7	3735	970	1441	45,728	147		
1.64	1.23	3435	869	1305	11,908	147		
1.59	2.32	3535	894	1328	25,220	147		
1.60	3.24	3635	890	1322	33,525	147		
1.61	7	3735	885	1314	46,027	147		
1.83	1.37	3435	779	1169	13,300	147		
1.79	2.60	3535	797	1184	25,856	147		
1.87	3.79	3635	762	1132	34,059	147		
1.78	8	3735	801	1190	46,319	147		
2.09	1.57	3435	681	1023	14,631	147		
2.00	2.90	3535	714	1061	25,869	147		
2.05	4	3635	695	1032	34,339	147		
2.08	10	3735	684	1016	46,731	147		

<sup>1</sup> motor not concerned by the IE

\* single phase motor for Compabloc 15 and Compabloc 30 only

LS, LSES 1500 min <sup>-1</sup> - 50 Hz		Cb - Gearbox					LS, LSES 2600 min <sup>-1</sup> - 87 Hz	
N <sub>s</sub> (min <sup>-1</sup> )	K <sub>p</sub>	Cb / MI-MU	i	M (Nm)	F <sub>R</sub> E/2 (N)	Dim. MI <— > page	N <sub>s</sub> (min <sup>-1</sup> )	K <sub>p</sub>
<b>0.25 kW - 50 Hz</b>		<i>Single phase LS 71 L-P<sup>1</sup>* - Three-phase LSES 71 M IFT/IE2 Single phase LS 71 L-P FMD<sup>1</sup>* - Three-phase LS 71 M FFB1<sup>1</sup></i>						
2.33	0.88	3335	612	919	4,492	147		
2.21	1.66	3435	644	967	15,089	147		
2.28	3.31	3535	625	928	25,865	147		
2.26	5	3635	630	935	34,612	147		
2.34	11	3735	608	903	46,997	147		
2.61	0.98	3335	546	820	6,123	147		
2.63	1.97	3435	543	815	16,190	147		
2.41	3.50	3535	591	878	25,861	147		
2.65	5	3635	537	798	34,999	147		
2.61	12	3735	546	811	47,212	147		
3.07	1.16	3335	464	697	7,884	147		
2.79	2.09	3435	511	768	16,481	147		
2.86	4	3535	498	739	25,853	147		
2.98	6	3635	477	709	35,248	147		
3.31	1.25	3335	431	646	8,522	147		
3.14	2.36	3435	453	680	16,959	147		
3.04	4	3535	469	696	25,854	147		
3.32	7	3635	429	637	35,450	147		
3.85	0.82	3235	371	556	1,224	147		
3.85	1.45	3335	370	555	9,543	147		
3.59	2.70	3435	396	595	17,344	147		
3.43	5	3535	416	617	25,860	147		
4.31	0.92	3235	331	497	2,028	147		
4.31	1.62	3335	330	496	10,118	147		
4.08	3.06	3435	349	524	17,602	147		
3.92	6	3535	364	540	25,877	147		
4.61	0.98	3235	309	464	2,606	147		
4.62	1.74	3335	308	463	10,409	147		
4.45	6	3535	320	475	25,901	147		
5.48	1.17	3235	260	391	4,087	147		
5.49	2.07	3335	260	390	10,974	147		
5.76	1.23	3235	247	371	4,509	147		
5.77	2.18	3335	247	371	11,107	147		
6.37	1.36	3235	224	336	5,277	147		
6.38	2.40	3335	223	335	11,329	147		
6.99	1.48	3233	204	309	5,849	133		
7.11	2.75	3333	200	304	11,505	135		
8.17	1.72	3233	174	265	6,749	133		
7.87	3.04	3333	181	275	11,653	135		
9.01	0.85	3133	158	240	2,571	131		
8.96	1.89	3233	159	241	7,182	133		
8.79	3.40	3333	162	246	11,782	135		
9.89	0.93	3133	144	218	3,188	131		
9.89	2.09	3233	144	219	7,502	133		
10.1	3.91	3333	141	214	11,907	135		
11.5	1.08	3133	124	189	3,973	131		
11.6	2.45	3233	123	187	7,594	133		
11.4	4.42	3333	125	189	11,988	135		
12.9	1.20	3133	111	168	4,463	131		
13.0	2.75	3233	109	166	7,654	133		
12.5	5	3333	114	174	12,032	135		
14.3	1.30	3133	99.4	151	4,852	131		
14.5	3.06	3233	98.2	149	7,703	133		
14.1	5	3333	101	153	12,084	135		

<sup>1</sup> motor not concerned by the IE

\* single phase motor for Compabloc 15 and Compabloc 30 only

LS, LSES 1500 min <sup>-1</sup> - 50 Hz		Cb - Gearbox					LS, LSES 2600 min <sup>-1</sup> - 87 Hz	
N <sub>S</sub> (min <sup>-1</sup> )	Kp	Cb / MI-MU	i	M (Nm)	F <sub>R</sub> E/2 (N)	Dim. MI <—> page	N <sub>S</sub> (min <sup>-1</sup> )	Kp
<b>0.25 kW - 50 Hz</b>		<i>Single phase LS 71 L-P<sup>1</sup>* - Three-phase LSES 71 M IFT/IE2 Single phase LS 71 L-P FMD<sup>1</sup>* - Three-phase LS 71 M FFB<sup>1</sup></i>						
16.4	1.43	3133	87	132	5,238	131		
16.5	3.48	3233	86.5	131	7,755	133		
15.8	6	3333	90.1	137	12,120	135		
17.3	1.49	3133	82.2	125	5,376	131		
18.3	3.86	3233	77.9	118	7,792	133		
17.6	7	3333	80.9	123	12,147	135		
20.6	0.86	3033	69.1	105	2,898	129		
20.6	1.67	3133	69.2	105	5,659	131		
20.8	4	3233	68.6	104	7,833	133		
19.1	7	3333	74.4	113	12,163	135		
22.2	0.93	3033	64.1	97	3,045	129		
21.8	1.74	3133	65.3	99	5,681	131		
22.2	5	3233	64.2	97	7,853	133		
21.6	8	3333	66.1	100	12,181	135		
25.9	1.08	3033	55	83	3,310	129		
24.6	1.89	3133	57.8	88	5,722	131		
25.6	5	3233	55.7	85	7,887	133		
29.0	1.21	3033	49.2	75	3,484	129		
29.0	2.71	3133 MI	49.1	75	5,770	131		
28.4	6	3233	50.2	77	7,910	133		
29.3	11	3333	48.7	75	12,208	135		
30.8	0.79	1503	46.2	70	1,710	125		
31.1	1.30	3033	45.9	70	3,582	129		
31.4	1.30	3032	45.4	70	4,200	127		
32.0	2.98	3133 MI	44.5	68	5,796	131		
33.2	7	3233	43	66	7,942	133		
32.4	12	3333	44	67	12,213	135		
35.0	0.87	1503	40.8	62	1,710	125		
35.3	1.46	3032	40.3	62	4,248	127		
36.9	1.54	3033	38.7	59	3,799	129		
36.7	3.41	3133	38.8	60	5,825	131		
36.4	8	3233	39.2	60	7,959	133		
36.2	13	3333	39.4	60	12,217	135		
38.7	0.94	1503	36.9	56	1,580	125		
38.8	1.62	3033	36.7	56	3,857	129		
39.9	1.64	3032	35.7	55	4,288	127		
40.3	3.74	3133	35.4	54	5,848	131		
40.1	8	3233	35.5	54	7,976	133		
41.7	15	3333	34.2	52	12,221	135		
42.9	1.78	3033	33.2	50	3,963	129		
43.9	1.80	3032	32.5	50	4,287	127		
46.6	4	3133	30.6	47	5,874	131		
47.0	10	3233	30.3	46	7,999	133		
47.1	17	3333	30.2	46	12,222	135		
50.6	1.16	1502	28.2	43	1,710	125		
49.4	2.03	3032	28.8	44	4,210	127		
52.3	5	3133	27.2	42	5,892	131		
52.9	11	3233	26.9	41	8,014	133		
51.3	19	3333	27.8	43	12,223	135		
58.1	1.30	1502	24.5	37	1,710	125		
55.7	2.28	3032	25.6	39	4,062	127		
58.4	5	3133	24.4	37	5,911	131		
58.9	12	3233	24.2	37	8,025	133		
58.0	21	3333	24.6	38	12,224	135		

<sup>1</sup> motor not concerned by the IE

\* single phase motor for Compabloc 15 and Compabloc 30 only

LS, LSES 1500 min <sup>-1</sup> - 50 Hz		Cb - Gearbox					LS, LSES 2600 min <sup>-1</sup> - 87 Hz	
N <sub>S</sub> (min <sup>-1</sup> )	Kp	Cb / MI-MU	i	M (Nm)	F <sub>R</sub> E/2 (N)	Dim. MI < ——— > page	N <sub>S</sub> (min <sup>-1</sup> )	Kp
<b>0.25 kW - 50 Hz</b>		<i>Single phase LS 71 L-P<sup>1</sup>* - Three-phase LSES 71 M IFT/IE2 Single phase LS 71 L-P FMD<sup>1</sup>* - Three-phase LS 71 M FFB<sup>1</sup></i>						
65.9	1.45	1502	21.6	33	1,800	125		
62.6	2.56	3032	22.8	35	3,919	127		
66.7	6	3133	21.4	33	5,926	131		
66.9	14	3233	21.3	33	8,037	133		
65.1	24	3333	21.9	34	12,224	135		
73.9	1.61	1502	19.3	29	1,800	125		
70.4	2.87	3032	20.2	31	3,782	127		
70.6	6	3133	20.2	31	5,933	131		
74.3	15	3233	19.2	29	8,045	133		
72.6	27	3333	19.6	30	12,224	135		
82.4	1.76	1502	17.3	26	1,800	125		
78.9	3.20	3032	18.1	28	3,651	127		
83.8	8	3133	17	26	5,704	131		
84.3	17	3233	16.9	26	7,722	133		
78.8	29	3333	18.1	28	12,223	135		
91.2	1.91	1502	15.6	24	1,800	125		
92.8	3.75	3032	15.4	24	3,471	127		
88.9	8	3133	16	25	5,595	131		
90.1	17	3233	15.8	24	7,560	133		
88.8	33	3333	16.1	25	12,223	135		
103	2.09	1502	13.9	21	1,802	125		
100	4	3032	14.2	22	3,392	127		
100	9	3133	14.2	22	5,388	131		
104	19	3233	13.7	21	7,220	133		
113	2.23	1502	12.7	19	1,802	125		
117	5	3032	12.2	19	3,234	127		
115	10	3133	12.4	19	5,167	131		
116	13	3233	12.3	19	6,949	133		
114	21	3333	12.5	19	12,786	135		
123	2.36	1502	11.6	18	1,802	125		
130	5	3032	10.9	17	3,122	127		
130	11	3133	10.9	17	4,959	131		
132	15	3233	10.8	17	6,667	133		
145	2.66	1502	9.81	15	1,802	125		
140	6	3032	10.2	16	3,054	127		
137	9	3133	10.4	16	4,877	131		
147	17	3233	9.72	15	6,446	133		
157	2.81	1502	9.07	14	1,613	125		
166	7	3032	8.59	13	2,895	127		
162	11	3133	8.79	13	4,621	131		
166	19	3233	8.57	13	6,187	133		
175	1.27	3031	8.13	13	1,691	113		
178	3.11	1502	7.99	12	1,613	125		
180	4	3131 MI	7.91	12	2,053	115		
176	6	3231	8.08	13	2,667	117		
175	7	3032	8.16	13	2,845	127		
172	11	3133	8.28	13	4,528	131		
182	12	3331	7.83	12	4,868	119		
178	20	3233	8.02	12	6,056	133		

<sup>1</sup> motor not concerned by the IE

\* single phase motor for Compabloc 15 and Compabloc 30 only

LS, LSES 1500 min <sup>-1</sup> - 50 Hz		Cb - Gearbox					LS, LSES 2600 min <sup>-1</sup> - 87 Hz	
N <sub>S</sub> (min <sup>-1</sup> )	Kp	Cb / MI-MU	i	M (Nm)	F <sub>R</sub> E/2 (N)	Dim. MI < ——— > page	N <sub>S</sub> (min <sup>-1</sup> )	Kp
<b>0.25 kW - 50 Hz</b>		<i>Single phase LS 71 L-P<sup>1</sup>* - Three-phase LSES 71 M IFT/IE2 Single phase LS 71 L-P FMD<sup>1</sup>* - Three-phase LS 71 M FFB<sup>1</sup></i>						
197	1.43	3031	7.22	11	1,658	113		
197	3.28	1502	7.23	11	1,613	125		
199	5	3131 MI	7.17	11	1,995	115		
206	7	3231	6.92	11	2,539	117		
193	8	3032	7.38	11	2,760	127		
194	13	3133	7.34	11	4,360	131		
201	14	3331	7.08	11	4,708	119		
223	1.61	3031	6.4	10	1,604	113		
228	5	3131	6.25	10	1,913	115		
226	8	3231	6.31	10	2,464	117		
222	14	3133	6.42	10	4,174	131		
225	15	3331	6.33	10	4,538	119		
245	1.78	3031	5.82	9	1,568	113		
250	6	3131	5.69	9	1,864	115		
249	9	3231	5.71	9	2,388	117		
252	16	3133	5.65	9	4,004	131		
259	18	3331	5.5	9	4,331	119		
276	2.00	3031	5.17	8	1,521	113		
290	7	3131	4.92	8	1,784	115		
292	11	3231	4.88	8	2,266	117		
293	20	3331	4.87	8	4,160	119		
311	2.25	3031	4.58	7	1,476	113		
325	7	3131	4.38	7	1,726	115		
329	12	3231	4.33	7	2,183	117		
319	22	3331	4.47	7	4,047	119		
350	2.53	3031	4.08	6	1,435	113		
363	8	3131	3.93	6	1,675	115		
366	13	3231	3.89	6	2,110	117		
361	25	3331	3.95	6	3,886	119		
393	2.85	3031	3.63	6	1,374	113		
415	9	3131	3.44	5	1,612	115		
416	15	3231	3.43	5	2,026	117		
405	27	3331	3.52	5	3,742	119		
440	3.19	3031	3.24	5	1,339	113		
438	10	3131	3.25	5	1,580	115		
462	17	3231	3.09	5	1,954	117		
451	28	3331	3.16	5	3,608	119		
518	3.76	3031	2.75	4	1,284	113		
521	12	3131	2.74	4	1,503	115		
524	19	3231	2.72	4	1,877	117		
490	33	3331	2.91	5	3,509	119		
559	4	3031	2.55	4	1,250	113		
553	13	3131	2.58	4	1,472	115		
560	20	3231	2.55	4	1,835	117		
552	37	3331	2.58	4	3,376	119		
651	5	3031	2.19	3	1,205	113		
623	14	3131	2.29	4	1,412	115		
645	23	3231	2.21	3	1,755	117		
728	5	3031	1.96	3	1,158	113		
713	16	3131	2	3	1,362	115		
780	6	3031	1.83	3	1,130	113		
810	17	3131	1.76	3	1,303	115		
926	7	3031	1.54	2	1,085	113		
975	7	3031	1.46	2	1,067	113		
1077	8	3031	1.32	2	1,030	113		

<sup>1</sup> motor not concerned by the IE

\* single phase motor for Compabloc 15 and Compabloc 30 only

LS, LSES 1500 min <sup>-1</sup> - 50 Hz		Cb - Gearbox					LS, LSES 2600 min <sup>-1</sup> - 87 Hz	
N <sub>s</sub> (min <sup>-1</sup> )	Kp	Cb / MI-MU	i	M (Nm)	F <sub>R</sub> E/2 (N)	Dim. MI < — > page	N <sub>s</sub> (min <sup>-1</sup> )	Kp
<b>0.37 kW - 50 Hz</b>		<i>Single phase LS 71 L-P<sup>1*</sup> - Three-phase LSES 71 M IFT/IE2 Single phase LS 71 L-P FMD<sup>1*</sup> - Three-phase LS 71 M FFB<sup>1</sup></i>						
0.25	0.79	3735	5770	12710	19,166	147		
0.28	0.92	3735	5010	11026	23,133	147		
0.31	0.95	3735	4600	10233	25,005	147		
0.36	1.11	3735	3940	8763	28,470	147		
0.40	1.21	3735	3590	7991	30,288	147		
0.44	1.34	3735	3250	7239	32,060	147		
0.51	1.57	3735	2770	6176	34,567	147		
0.58	1.77	3735	2470	5490	36,184	147		
0.65	0.88	3635	2180	4852	23,599	147		
0.64	1.96	3735	2220	4934	37,494	147		
0.73	0.99	3635	1940	4313	25,115	147		
0.73	2.23	3735	1950	4344	38,886	147		
0.82	0.80	3535	1740	3909	8,923	147		
0.82	1.11	3635	1740	3876	26,343	147		
0.81	2.48	3735	1760	3911	39,906	147		
0.93	1.26	3635	1530	3412	27,647	147		
0.92	2.81	3735	1550	3446	41,002	147		
0.99	0.95	3535	1440	3235	13,178	147		
1.03	1.40	3635	1380	3072	28,603	147		
0.98	3.01	3735	1450	3225	41,523	147		
1.09	1.05	3535	1300	2931	15,098	147		
1.17	1.58	3635	1220	2707	29,630	147		
1.13	3.46	3735	1260	2798	42,530	147		
1.25	1.20	3535	1140	2556	17,466	147		
1.25	1.69	3635	1140	2533	30,119	147		
1.25	3.80	3735	1130	2548	43,118	147		
1.37	1.32	3535	1040	2328	18,906	147		
1.44	1.95	3635	988	2198	31,062	147		
1.46	4	3735	970	2182	43,981	147		
1.63	0.81	3435	869	1976	3,315	147		
1.59	1.53	3535	894	2011	20,908	147		
1.60	2.14	3635	890	2002	31,613	147		
1.61	5	3735	885	1990	44,434	147		
1.82	0.91	3435	779	1771	6,190	147		
1.78	1.71	3535	797	1793	22,284	147		
1.86	2.50	3635	762	1714	32,422	147		
1.77	5	3735	801	1803	44,875	147		
2.08	1.04	3435	681	1549	9,069	147		
1.99	1.91	3535	714	1607	23,458	147		
2.04	2.74	3635	695	1563	32,846	147		
2.08	6	3735	684	1538	45,499	147		
2.20	1.10	3435	644	1465	10,095	147		
2.27	2.19	3535	625	1406	24,728	147		
2.26	3.03	3635	630	1416	33,260	147		
2.34	7	3735	608	1367	45,902	147		
2.62	1.30	3435	543	1233	12,659	147		
2.40	2.31	3535	591	1329	25,214	147		
2.64	3.55	3635	537	1208	33,845	147		
2.60	8	3735	546	1229	46,228	147		
2.78	1.38	3435	511	1162	13,367	147		
2.85	2.75	3535	498	1119	25,866	147		
2.97	3.99	3635	477	1074	34,222	147		
2.95	9	3735	481	1082	46,575	147		
3.30	0.82	3335	431	979	3,408	147		
3.13	1.56	3435	453	1030	14,570	147		
3.03	2.91	3535	469	1055	25,869	147		
3.31	4	3635	429	965	34,528	147		
3.28	10	3735	433	974	46,829	147		
3.84	0.96	3335	370	841	5,796	147		
3.58	1.78	3435	396	901	15,591	147		
3.42	3.29	3535	416	935	25,865	147		
3.76	5	3635	378	850	34,853	147		
3.72	11	3735	381	858	47,102	147		

<sup>1</sup> motor not concerned by the IE

\* single phase motor for Compabloc 15 and Compabloc 30 only

LS, LSES 1500 min <sup>-1</sup> - 50 Hz		Cb - Gearbox					LS, LSES 2600 min <sup>-1</sup> - 87 Hz	
N <sub>S</sub> (min <sup>-1</sup> )	Kp	Cb / MI-MU	i	M (Nm)	F <sub>R</sub> E/2 (N)	Dim. MI ← — — — → page	N <sub>S</sub> (min <sup>-1</sup> )	Kp
<b>0.37 kW - 50 Hz</b>		<i>Single phase LS 71 L-P<sup>1</sup>* - Three-phase LSES 71 M IFT/IE2 Single phase LS 71 L-P FMD<sup>1</sup>* - Three-phase LS 71 M FFB<sup>1</sup></i>						
4.30	1.07	3335	330	751	7,148	147		
4.07	2.02	3435	349	793	16,324	147		
3.91	3.76	3535	364	818	25,857	147		
4.18	6	3635	340	765	35,091	147		
3.98	12	3735	357	803	47,232	147		
4.61	1.15	3335	308	701	7,832	147		
4.44	4	3535	320	720	25,853	147		
4.74	6	3635	300	674	35,346	147		
5.47	1.36	3335	260	591	9,167	147		
5.06	7	3635	280	631	35,468	147		
5.74	0.81	3235	247	562	1,166	147		
5.75	1.44	3335	247	561	9,483	147		
6.35	0.90	3235	224	509	1,842	147		
6.36	1.59	3335	223	508	10,010	147		
6.97	0.97	3233	204	468	2,526	133		
7.08	1.81	3333	200	461	10,429	135		
8.14	1.14	3233	174	401	3,870	133		
7.84	2.01	3333	181	416	10,784	135		
8.93	1.25	3233	159	366	4,631	133		
8.76	2.24	3333	162	372	11,095	135		
9.85	1.38	3233	144	331	5,379	133		
10.1	2.58	3333	141	323	11,399	135		
11.6	1.62	3233	123	283	6,398	133		
11.4	2.92	3333	125	286	11,598	135		
12.8	0.79	3133	111	255	2,114	131		
13.0	1.82	3233	109	251	7,005	133		
12.4	3.17	3333	114	263	11,707	135		
14.3	0.86	3133	99.4	228	2,909	131		
14.5	2.02	3233	98.2	226	7,453	133		
14.0	3.59	3333	101	232	11,837	135		
16.3	0.95	3133	87	200	3,690	131		
16.4	2.30	3233	86.5	199	7,559	133		
15.8	4	3333	90.1	207	11,929	135		
17.3	0.99	3133	82.2	189	3,968	131		
18.2	2.55	3233	77.9	179	7,617	133		
17.6	4	3333	80.9	186	11,997	135		
20.5	1.11	3133	69.2	159	4,671	131		
20.7	2.90	3233	68.6	158	7,677	133		
19.1	5	3333	74.4	171	12,039	135		
21.8	1.15	3133	65.3	150	4,871	131		
22.1	3.09	3233	64.2	148	7,706	133		
21.5	6	3333	66.1	152	12,087	135		
24.6	1.25	3133	57.8	133	5,220	131		
25.5	3.57	3233	55.7	128	7,764	133		
28.9	0.80	3033	49.2	113	2,743	129		
28.9	1.79	3133 MI	49.1	114	5,572	131		
28.3	3.92	3233	50.2	117	7,795	133		
29.2	7	3333	48.7	113	12,163	135		
31.0	0.86	3033	45.9	105	2,887	129		
31.3	0.86	3032	45.4	105	3,590	127		
31.9	1.97	3133 MI	44.5	103	5,666	131		
33.0	5	3233	43	100	7,844	133		
32.3	8	3333	44	102	12,179	135		
35.2	0.96	3032	40.3	94	3,623	127		
36.7	1.01	3033	38.7	89	3,207	129		
36.6	2.25	3133	38.8	90	5,714	131		
36.2	5	3233	39.2	91	7,870	133		
36.1	9	3333	39.4	91	12,192	135		

<sup>1</sup> motor not concerned by the IE

\* single phase motor for Compabloc 15 and Compabloc 30 only



LS, LSES 1500 min <sup>-1</sup> - 50 Hz		Cb - Gearbox					LS, LSES 2600 min <sup>-1</sup> - 87 Hz	
N <sub>S</sub> (min <sup>-1</sup> )	Kp	Cb / MI-MU	i	M (Nm)	F <sub>R</sub> E/2 (N)	Dim. MI <—> page	N <sub>S</sub> (min <sup>-1</sup> )	Kp
<b>0.37 kW - 50 Hz</b>		<i>Single phase LS 71 L-P<sup>1</sup>* - Three-phase LSES 71 M IFT/IE2 Single phase LS 71 L-P FMD<sup>1</sup>* - Three-phase LS 71 M FFB<sup>1</sup></i>						
38.7	1.07	3033	36.7	84	3,293	129		
39.7	1.08	3032	35.7	83	3,659	127		
40.1	2.47	3133	35.4	82	5,744	131		
40.0	6	3233	35.5	82	7,896	133		
41.6	10	3333	34.2	79	12,204	135		
42.7	1.17	3033	33.2	76	3,450	129		
43.7	1.19	3032	32.5	75	3,678	127		
46.5	2.85	3133	30.6	71	5,785	131		
46.9	6	3233	30.3	70	7,930	133		
47.0	11	3333	30.2	70	12,211	135		
49.2	1.34	3032	28.8	67	3,661	127		
52.1	3.19	3133	27.2	63	5,814	131		
52.7	7	3233	26.9	63	7,951	133		
51.1	12	3333	27.8	65	12,215	135		
55.5	1.50	3032	25.6	59	3,650	127		
58.2	3.55	3133	24.4	57	5,837	131		
58.7	8	3233	24.2	56	7,971	133		
57.8	14	3333	24.6	57	12,219	135		
62.4	1.69	3032	22.8	53	3,602	127		
66.5	4	3133	21.4	50	5,863	131		
66.7	9	3233	21.3	49	7,991	133		
64.9	16	3333	21.9	51	12,221	135		
70.2	1.89	3032	20.2	47	3,561	127		
70.3	4	3133	20.2	47	5,874	131		
74.0	10	3233	19.2	45	7,972	133		
72.3	18	3333	19.6	46	12,223	135		
82.1	1.16	1502	17.3	40	1,710	125		
78.6	2.12	3032	18.1	42	3,509	127		
83.5	5	3133	17	39	5,626	131		
84.0	11	3233	16.9	39	7,664	133		
78.6	19	3333	18.1	42	12,223	135		
90.9	1.26	1502	15.6	36	1,800	125		
92.5	2.48	3032	15.4	36	3,414	127		
88.6	5	3133	16	37	5,524	131		
89.8	12	3233	15.8	37	7,503	133		
88.5	22	3333	16.1	37	12,224	135		
102	1.38	1502	13.9	32	1,651	125		
99.7	2.67	3032	14.2	33	3,340	127		
100	6	3133	14.2	33	5,323	131		
103	13	3233	13.7	32	7,173	133		
112	1.47	1502	12.7	29	1,651	125		
116	3.09	3032	12.2	28	3,192	127		
114	7	3133	12.4	29	5,108	131		
116	9	3233	12.3	28	6,904	133		
114	14	3333	12.5	29	12,796	135		
122	1.56	1502	11.6	27	1,651	125		
130	3.45	3032	10.9	25	3,084	127		
130	7	3133	10.9	25	4,913	131		
131	10	3233	10.8	25	6,627	133		
145	1.76	1502	9.81	23	1,802	125		
139	3.69	3032	10.2	24	3,016	127		
136	6	3133	10.4	24	4,826	131		
146	11	3233	9.72	23	6,406	133		
157	1.86	1502	9.07	21	1,613	125		
165	4	3032	8.59	20	2,863	127		
162	7	3133	8.79	20	4,576	131		
166	13	3233	8.57	20	6,154	133		

<sup>1</sup> motor not concerned by the IE

\* single phase motor for Compabloc 15 and Compabloc 30 only

LS, LSES 1500 min <sup>-1</sup> - 50 Hz		Cb - Gearbox					LS, LSES 2600 min <sup>-1</sup> - 87 Hz	
N <sub>S</sub> (min <sup>-1</sup> )	Kp	Cb / MI-MU	i	M (Nm)	F <sub>R</sub> E/2 (N)	Dim. MI <—> page	N <sub>S</sub> (min <sup>-1</sup> )	Kp
<b>0.37 kW - 50 Hz</b>		<i>Single phase LS 71 L-P<sup>1</sup>* - Three-phase LSES 71 M IFT/IE2 Single phase LS 71 L-P FMD<sup>1</sup>* - Three-phase LS 71 M FFB1<sup>1</sup></i>						
175	0.84	3031	8.13	19	1,568	113		
178	2.05	1502	7.99	19	1,613	125		
180	2.70	3131 MI	7.91	19	1,958	115		
176	4	3231	8.08	19	2,639	117		
174	5	3032	8.16	19	2,817	127		
172	7	3133	8.28	19	4,491	131		
181	8	3331	7.83	18	4,851	119		
177	13	3233	8.02	19	6,022	133		
197	0.94	3031	7.22	17	1,535	113		
196	2.16	1502	7.23	17	1,613	125		
198	2.97	3131 MI	7.17	17	1,914	115		
205	5	3231	6.92	16	2,515	117		
192	5	3032	7.38	17	2,732	127		
194	8	3133	7.34	17	4,323	131		
201	9	3331	7.08	17	4,690	119		
222	1.07	3031	6.4	15	1,501	113		
227	3.41	3131	6.25	15	1,847	115		
225	5	3231	6.31	15	2,439	117		
221	9	3133	6.42	15	4,143	131		
224	10	3331	6.33	15	4,524	119		
244	1.17	3031	5.82	14	1,465	113		
249	3.75	3131	5.69	13	1,811	115		
249	6	3231	5.71	13	2,369	117		
251	11	3133	5.65	13	3,980	131		
258	12	3331	5.5	13	4,320	119		
275	1.32	3031	5.17	12	1,439	113		
289	4	3131	4.92	12	1,730	115		
291	7	3231	4.88	11	2,253	117		
292	13	3331	4.87	11	4,153	119		
310	1.49	3031	4.58	11	1,394	113		
324	5	3131	4.38	10	1,687	115		
328	8	3231	4.33	10	2,168	117		
317	14	3331	4.47	10	4,040	119		
348	1.67	3031	4.08	10	1,353	113		
361	5	3131	3.93	9	1,635	115		
365	9	3231	3.89	9	2,094	117		
359	16	3331	3.95	9	3,878	119		
392	1.88	3031	3.63	9	1,313	113		
413	6	3131	3.44	8	1,572	115		
414	10	3231	3.43	8	2,010	117		
403	18	3331	3.52	8	3,734	119		
439	2.11	3031	3.24	8	1,279	113		
437	7	3131	3.25	8	1,541	115		
460	11	3231	3.09	7	1,944	117		
449	19	3331	3.16	7	3,604	119		
516	2.48	3031	2.75	6	1,244	113		
519	8	3131	2.74	6	1,477	115		
522	13	3231	2.72	6	1,867	117		
488	22	3331	2.91	7	3,504	119		
557	2.68	3031	2.55	6	1,211	113		
551	8	3131	2.58	6	1,446	115		
558	13	3231	2.55	6	1,824	117		
550	25	3331	2.58	6	3,371	119		
648	3.11	3031	2.19	5	1,165	113		
621	9	3131	2.29	5	1,400	115		
643	15	3231	2.21	5	1,743	117		
726	3.49	3031	1.96	5	1,118	113		
710	10	3131	2	5	1,336	115		
778	3.74	3031	1.83	4	1,112	113		
807	11	3131	1.76	4	1,292	115		
923	4	3031	1.54	4	1,045	113		
972	5	3031	1.46	3	1,047	113		
1074	5	3031	1.32	3	1,010	113		

<sup>1</sup> motor not concerned by the IE

\* single phase motor for Compabloc 15 and Compabloc 30 only

LS, LSES 1500 min <sup>-1</sup> - 50 Hz		Cb - Gearbox					LS, LSES 2600 min <sup>-1</sup> - 87 Hz	
N <sub>s</sub> (min <sup>-1</sup> )	Kp	Cb / MI-MU	i	M (Nm)	F <sub>R</sub> E/2 (N)	Dim. MI < ——— > page	N <sub>s</sub> (min <sup>-1</sup> )	Kp
<b>0.55 kW - 50 Hz</b>		<i>LSES 71 LR IFT/IE2 LS 71 L FFB1<sup>1</sup></i>						
0.39	0.79	3735	3590	12209	20,554	147		
0.43	0.88	3735	3250	11061	23,242	147		
0.50	1.03	3735	2770	9436	27,044	147		
0.57	1.16	3735	2470	8388	29,497	147		
0.63	1.29	3735	2220	7539	31,484	147		
0.72	1.46	3735	1950	6637	33,595	147		
0.80	1.62	3735	1760	5975	35,142	147		
0.91	0.82	3635	1530	5214	22,689	147		
0.90	1.84	3735	1550	5265	36,805	147		
1.01	0.91	3635	1380	4694	24,139	147		
0.97	1.97	3735	1450	4927	37,595	147		
1.15	1.04	3635	1220	4136	25,697	147		
1.11	2.27	3735	1260	4275	39,122	147		
1.23	0.79	3535	1140	3906	9,125	147		
1.23	1.11	3635	1140	3871	26,437	147		
1.24	2.49	3735	1130	3893	40,014	147		
1.35	0.86	3535	1040	3557	11,309	147		
1.42	1.28	3635	988	3358	27,868	147		
1.44	2.91	3735	970	3334	41,323	147		
1.57	1.00	3535	894	3072	14,347	147		
1.57	1.40	3635	890	3059	28,704	147		
1.58	3.19	3735	885	3040	42,010	147		
1.76	1.12	3535	797	2740	16,430	147		
1.84	1.64	3635	762	2619	29,931	147		
1.75	3.52	3735	801	2754	42,679	147		
1.96	1.25	3535	714	2455	18,217	147		
2.01	1.80	3635	695	2389	30,575	147		
2.05	4	3735	684	2350	43,626	147		
2.24	1.43	3535	625	2148	20,143	147		
2.22	1.98	3635	630	2164	31,202	147		
2.30	5	3735	608	2089	44,237	147		
2.58	0.85	3435	543	1885	4,808	147		
2.37	1.51	3535	591	2031	20,876	147		
2.61	2.32	3635	537	1846	32,089	147		
2.56	5	3735	546	1877	44,732	147		
2.74	0.90	3435	511	1776	6,293	147		
2.81	1.80	3535	498	1710	22,884	147		
2.93	2.61	3635	477	1641	32,662	147		
2.91	6	3735	481	1653	45,257	147		
3.09	1.02	3435	453	1574	8,904	147		
2.99	1.91	3535	469	1612	23,502	147		
3.26	2.91	3635	429	1475	33,125	147		
3.23	7	3735	433	1488	45,643	147		
3.53	1.17	3435	396	1377	11,222	147		
3.37	2.15	3535	416	1428	24,652	147		
3.71	3.30	3635	378	1298	33,618	147		
3.67	7	3735	381	1311	46,057	147		
4.01	1.32	3435	349	1212	12,966	147		
3.85	2.46	3535	364	1250	25,770	147		
4.12	3.67	3635	340	1169	33,979	147		
3.92	8	3735	357	1227	46,254	147		
4.38	2.80	3535	320	1100	25,868	147		
4.67	4	3635	300	1030	34,367	147		
4.52	9	3735	310	1064	46,634	147		

<sup>1</sup> motor not concerned by the IE

LS, LSES 1500 min <sup>-1</sup> - 50 Hz		Cb - Gearbox					LS, LSES 2600 min <sup>-1</sup> - 87 Hz	
N <sub>S</sub> (min <sup>-1</sup> )	Kp	Cb / MI-MU	i	M (Nm)	F <sub>R</sub> E/2 (N)	Dim. MI <— > page	N <sub>S</sub> (min <sup>-1</sup> )	Kp
<b>0.55 kW - 50 Hz</b>		LSES 71 LR IFT/IE2 LS 71 L FFB1 <sup>1</sup>						
5.39	0.89	3335	260	902	4,891	147		
4.99	4	3635	280	964	34,551	147		
5.15	10	3735	272	934	46,939	147		
5.67	0.94	3335	247	857	5,634	147		
5.79	1.91	3435	242	839	16,068	147		
6.27	1.04	3335	223	776	6,875	147		
6.11	2.02	3435	229	796	16,342	147		
6.13	3.92	3535	222	785	25,855	147		
6.98	1.19	3333	200	704	7,866	135		
7.73	1.31	3333	181	636	8,706	135		
8.80	0.82	3233	159	558	1,244	133		
8.64	1.47	3333	162	569	9,444	135		
9.71	0.90	3233	144	506	1,941	133		
9.95	1.69	3333	141	494	10,169	135		
11.4	1.06	3233	123	432	3,294	133		
11.2	1.91	3333	125	437	10,646	135		
12.8	1.19	3233	109	384	4,298	133		
12.2	2.08	3333	114	402	10,911	135		
14.3	1.32	3233	98.2	345	5,136	133		
13.8	2.35	3333	101	355	11,224	135		
16.2	1.50	3233	86.5	304	6,011	133		
15.5	2.64	3333	90.1	316	11,451	135		
18.0	1.67	3233	77.9	273	6,620	133		
17.3	2.94	3333	80.9	284	11,619	135		
20.4	1.89	3233	68.6	241	7,223	133		
18.8	3.20	3333	74.4	261	11,723	135		
21.8	2.02	3233	64.2	225	7,486	133		
21.2	3.60	3333	66.1	232	11,844	135		
24.2	0.82	3133	57.8	203	3,646	131		
25.1	2.33	3233	55.7	196	7,574	133		
24.3	4	3333	57.6	202	11,951	135		
27.7	0.90	3133	50.6	178	4,275	131		
27.9	2.56	3233	50.2	178	7,623	133		
28.8	5	3333	48.7	173	12,038	135		
31.4	0.98	3133	44.53	156	4,757	131		
32.6	2.99	3233	43	152	7,697	133		
31.8	5	3333	44	156	12,080	135		
36.1	1.48	3133	38.8	138	5,143	131		
35.7	3.27	3233	39.2	139	7,735	133		
35.6	6	3333	39.4	140	12,117	135		
39.6	1.62	3133	35.4	125	5,380	131		
39.4	3.60	3233	35.5	126	7,772	133		
41.0	7	3333	34.2	121	12,151	135		
45.8	1.87	3133	30.6	108	5,647	131		
46.2	4	3233	30.3	107	7,824	133		
46.3	8	3333	30.2	107	12,172	135		
51.4	2.09	3133	27.2	97	5,692	131		
52.0	5	3233	26.9	96	7,859	133		
50.4	8	3333	27.8	99	12,184	135		
54.7	0.99	3032	25.6	91	2,898	127		
57.4	2.33	3133	24.4	87	5,729	131		
57.8	5	3233	24.2	86	7,887	133		
57.0	9	3333	24.6	87	12,197	135		

<sup>1</sup> motor not concerned by the IE

LS, LSES 1500 min <sup>-1</sup> - 50 Hz		Cb - Gearbox					LS, LSES 2600 min <sup>-1</sup> - 87 Hz	
N <sub>S</sub> (min <sup>-1</sup> )	Kp	Cb / MI-MU	i	M (Nm)	F <sub>R</sub> E/2 (N)	Dim. MI <— > page	N <sub>S</sub> (min <sup>-1</sup> )	Kp
<b>0.55 kW - 50 Hz</b>		<i>LSES 71 LR IFT/IE2 LS 71 L FFB1<sup>1</sup></i>						
61.5	1.11	3032	22.8	81	2,949	127		
65.5	2.65	3133	21.4	76	5,770	131		
65.7	6	3233	21.3	76	7,916	133		
64.0	10	3333	21.9	78	12,206	135		
69.2	1.24	3032	20.2	72	2,981	127		
69.3	2.8	3133	20.2	72	5,778	131		
73.0	7	3233	19.2	68	7,873	133		
71.3	12	3333	19.6	70	12,212	135		
77.5	1.39	3032	18.1	64	2,978	127		
82.3	3.31	3133	17	60	5,503	131		
82.8	7	3233	16.9	60	7,574	133		
77.4	13	3333	18.1	64	12,215	135		
91.2	1.62	3032	15.4	54	2,984	127		
87.4	3.50	3133	16	57	5,413	131		
88.5	8	3233	15.8	56	7,423	133		
87.2	14	3333	16.1	57	12,219	135		
98.3	1.75	3032	14.2	51	2,975	127		
98.6	3.94	3133	14.2	50	5,224	131		
102	8	3233	13.7	49	7,107	133		
100	16	3333	14	50	12,222	135		
114	2.03	3032	12.2	43	2,940	127		
113	4	3133	12.4	44	5,022	131		
116	9	3233	12	43	6,824	133		
112	9	3333	12.5	44	12,800	135		
128	2.26	3032	10.9	39	2,915	127		
128	5	3133	10.9	39	4,833	131		
130	7	3233	10.8	38	6,567	133		
126	10	3333	11.1	39	12,803	135		
137	2.42	3032	10.2	36	2,877	127		
134	3.82	3133	10.4	37	4,745	131		
144	7	3233	9.72	34	6,357	133		
141	12	3333	9.95	35	12,395	135		
163	2.85	3032	8.59	30	2,816	127		
159	5	3133	8.79	31	4,509	131		
163	8	3233	8.57	30	6,110	133		
173	2.76	3231	8.08	29	2,592	117		
172	3.00	3032	8.16	29	2,773	127		
179	5	3331	7.83	28	4,824	119		
185	6	3133	7.57	27	4,325	131		
175	9	3233	8.02	28	5,984	133		
172	14	3333	8.14	29	11,606	135		
202	3.23	3231	6.92	25	2,472	117		
190	3.30	3032	7.38	26	2,693	127		
191	5	3133	7.34	26	4,269	131		
198	6	3331	7.08	25	4,670	119		
201	10	3233	6.96	25	5,723	133		
198	16	3333	7.09	25	11,095	135		
224	2.23	3131	6.25	22	1,754	115		
222	3.54	3231	6.31	23	2,407	117		
218	6	3133	6.42	23	4,096	131		
221	7	3331	6.33	23	4,504	119		
229	12	3233	6.1	22	5,490	133		

<sup>1</sup> motor not concerned by the IE

LS, LSES 1500 min <sup>-1</sup> - 50 Hz		Cb - Gearbox					LS, LSES 2600 min <sup>-1</sup> - 87 Hz	
N <sub>S</sub> (min <sup>-1</sup> )	Kp	Cb / MI-MU	i	M (Nm)	F <sub>R</sub> E/2 (N)	Dim. MI <—> page	N <sub>S</sub> (min <sup>-1</sup> )	Kp
<b>0.55 kW - 50 Hz</b>		<i>LSES 71 LR IFT/IE2 LS 71 L FFB1<sup>1</sup></i>						
246	2.45	3131	5.69	20	1,719	115		
245	3.91	3231	5.71	20	2,336	117		
248	7	3133	5.65	20	3,940	131		
255	8	3331	5.5	20	4,303	119		
285	2.84	3131	4.92	18	1,665	115		
287	5	3231	4.88	17	2,224	117		
288	9	3331	4.87	17	4,138	119		
305	0.97	3031	4.58	16	1,293	113		
319	3.18	3131	4.38	16	1,607	115		
323	5	3231	4.33	16	2,144	117		
313	9	3331	4.47	16	4,025	119		
343	1.10	3031	4.08	15	1,252	113		
356	3.55	3131	3.93	14	1,570	115		
359	6	3231	3.89	14	2,070	117		
358	8	3133	3.91	14	3,512	131		
354	11	3331	3.95	14	3,866	119		
386	1.23	3031	3.63	13	1,233	113		
407	4	3131	3.44	12	1,521	115		
408	7	3231	3.43	12	1,991	117		
377	9	3133	3.71	13	3,456	131		
398	12	3331	3.52	13	3,721	119		
433	1.38	3031	3.24	12	1,198	113		
431	4	3131	3.25	12	1,490	115		
454	7	3231	3.09	11	1,924	117		
443	12	3331	3.16	11	3,595	119		
509	1.62	3031	2.75	10	1,164	113		
512	5	3131	2.74	10	1,425	115		
515	8	3231	2.72	10	1,846	117		
481	14	3331	2.91	10	3,498	119		
549	1.75	3031	2.55	9	1,150	113		
543	5	3131	2.58	9	1,409	115		
550	9	3231	2.55	9	1,809	117		
542	16	3331	2.58	9	3,364	119		
639	2.04	3031	2.19	8	1,105	113		
613	6	3131	2.29	8	1,362	115		
634	10	3231	2.21	8	1,727	117		
622	17	3331	2.25	8	3,214	119		
716	2.28	3031	1.96	7	1,079	113		
700	7	3131	2	7	1,311	115		
723	12	3231	1.94	7	1,656	117		
767	2.45	3031	1.83	7	1,051	113		
795	7	3131	1.76	6	1,266	115		
910	2.90	3031	1.54	6	1,027	113		
958	3.06	3031	1.46	5	1,007	113		
1059	3.38	3031	1.32	5	971	113		
1149	8	3131	1.22	4	1,139	115		
1211	9	3131	1.16	4	1,118	115		

<sup>1</sup> motor not concerned by the IE

Selection tables

Compabloc: Cb / LS, LSES motors / 4 poles

LS, LSES 1500 min <sup>-1</sup> - 50 Hz		Cb - Gearbox					LS, LSES 2600 min <sup>-1</sup> - 87 Hz	
N <sub>S</sub> (min <sup>-1</sup> )	Kp	Cb / MI-MU	i	M (Nm)	F <sub>R</sub> E/2 (N)	Dim. MI < ——— > page	N <sub>S</sub> (min <sup>-1</sup> )	Kp
<b>0.75 kW - 50 Hz</b>		<i>LSES 80 LG IFT/IE3</i> <i>LS 80 L FFB1 IFT/NIE - LSES 80 LG FFB1 IFT/IE3</i>					<b>1.31 kW - 87 Hz*</b>	
0.35	0.80	3835	3980	18511	36,525	147		
0.42	0.95	3835	3360	15616	40,969	147		
0.46	1.05	3835	3030	14064	42,963	147		
0.51	1.16	3835	2740	12733	44,455	147		
0.57	0.84	3735	2470	11517	21,977	147		
0.55	1.26	3835	2530	11731	45,446	147		
0.63	0.94	3735	2220	10351	24,724	147		
0.72	1.06	3735	1950	9112	27,645	147		
0.80	1.18	3735	1760	8205	29,785	147		
0.90	1.34	3735	1550	7229	32,084	147		
0.97	1.43	3735	1450	6765	33,178	147		
1.11	1.65	3735	1260	5869	35,290	147		
1.23	0.81	3635	1140	5315	22,298	147		
1.24	1.81	3735	1130	5346	36,524	147		
1.42	0.93	3635	988	4611	24,277	147		
1.44	2.12	3735	970	4578	38,334	147		
1.42	3.20	3835	983	4617	49,228	147		
1.57	1.02	3635	890	4200	25,433	147		
1.58	2.32	3735	885	4175	39,284	147		
1.69	3.79	3835	829	3895	49,292	147		
1.76	0.82	3535	797	3762	9,851	147	3.14	0.84
1.84	1.19	3635	762	3596	27,130	147		
1.75	2.56	3735	801	3782	40,210	147		
1.87	4	3835	747	3508	49,302	147		
1.96	0.91	3535	714	3371	12,320	147	3.50	0.94
2.01	1.31	3635	695	3280	28,020	147		
2.05	3.00	3735	684	3227	41,519	147		
2.07	5	3835	676	3176	49,298	147		
2.24	1.04	3535	625	2949	14,984	147	4.00	1.07
2.22	1.44	3635	630	2971	28,888	147		
2.30	3.38	3735	608	2868	42,364	147		
2.25	5	3835	623	2926	49,286	147		
2.37	1.10	3535	591	2789	15,995	147	4.23	1.14
2.61	1.69	3635	537	2535	30,115	147		
2.56	3.76	3735	546	2578	43,048	147		
2.81	1.31	3535	498	2348	18,779	147	5.02	1.35
2.93	1.90	3635	477	2253	30,907	147		
2.91	4	3735	481	2269	43,776	147		
2.99	1.39	3535	469	2213	19,632	147	5.33	1.43
3.26	2.12	3635	429	2025	31,548	147		
3.23	5	3735	433	2043	44,309	147		
3.53	0.85	3435	396	1891	4,525	147	6.31	0.87
3.37	1.57	3535	416	1961	21,223	147	6.02	1.62
3.71	2.41	3635	378	1783	32,229	147		
3.67	5	3735	381	1800	44,881	147		
4.01	0.96	3435	349	1664	7,607	147	7.17	0.99
3.85	1.79	3535	364	1716	22,770	147	6.88	1.85
4.12	2.67	3635	340	1605	32,729	147		
3.92	6	3735	357	1685	45,154	147		
4.38	2.04	3535	320	1510	24,071	147	7.81	2.1
4.67	3.03	3635	300	1414	33,265	147		
4.52	7	3735	310	1462	45,679	147		
4.99	3.24	3635	280	1324	33,520	147		
5.15	8	3735	272	1282	46,102	147		

87Hz\* 400VY triangle-coupled motor supplied by drive



LS, LSES 1500 min <sup>-1</sup> - 50 Hz		Cb - Gearbox					LS, LSES 2600 min <sup>-1</sup> - 87 Hz	
N <sub>s</sub> (min <sup>-1</sup> )	Kp	Cb / MI-MU	i	M (Nm)	F <sub>R</sub> E/2 (N)	Dim. MI < ——— > page	N <sub>s</sub> (min <sup>-1</sup> )	Kp
<b>0.75 kW - 50 Hz</b>		LSES 80 LG IFT/IE2 - LSES 80 LG IFT/IE3 LS 80 L FFB1 IFT/NIE - LSES 80 LG FFB1 IFT/IE3					<b>1.31 kW - 87 Hz*</b>	
5.79	1.39	3435	242	1152	13,463	147	10.4	1.44
6.11	1.47	3435	229	1093	14,015	147	10.9	1.51
6.13	2.85	3535	222	1077	25,868	147	11.0	2.94
6.98	0.86	3333	200	966	3,646	135	12.5	0.89
6.86	1.66	3433	204	980	14,984	137	12.3	1.70
7.73	0.96	3333	181	873	5,278	135	13.8	0.99
8.14	1.97	3433	172	827	16,108	137	14.5	2.01
8.64	1.07	3333	162	781	6,714	135	15.4	1.10
9.03	2.18	3433	155	743	16,622	137	16.1	2.23
9.95	1.23	3333	141	678	8,127	135	17.8	1.27
9.98	2.41	3433	140	673	16,996	137	17.8	2.46
11.2	1.39	3333	125	600	9,060	135	20.1	1.43
10.8	2.61	3433	129	620	17,240	137	19.3	2.67
12.8	0.87	3233	109	527	1,580	133	22.9	0.89
12.2	1.51	3333	114	552	9,579	135	21.8	1.56
12.6	3.03	3433	111	533	17,573	137	22.5	3.09
14.3	0.96	3233	98.2	473	2,427	133	25.5	0.99
13.8	1.71	3333	101	487	10,195	135	24.7	1.77
16.2	1.09	3233	86.5	417	3,534	133	28.9	1.13
15.5	1.92	3333	90.1	434	10,643	135	27.7	1.98
18.0	1.22	3233	77.9	375	4,419	133	32.1	1.25
17.3	2.14	3333	80.9	390	10,976	135	30.9	2.20
20.4	1.38	3233	68.6	331	5,388	133	36.4	1.42
18.8	2.33	3333	74.4	359	11,184	135	33.6	2.39
21.8	1.47	3233	64.2	309	5,841	133	38.9	1.51
21.2	2.62	3333	66.1	319	11,425	135	37.8	2.69
25.1	1.70	3233	55.7	268	6,676	133	44.9	1.74
24.3	3.01	3333	57.6	278	11,640	135	43.4	3.08
27.9	1.87	3233	50.2	244	7,127	133	49.8	1.90
28.8	3.40	3333	48.7	237	11,818	135	51.4	3.50
27.8	7	3433	50.3	244	18,001	137	49.7	7
32.6	2.18	3233	43	209	7,531	133	58.2	2.21
31.8	3.76	3333	44	214	11,904	135	56.9	3.88
33.0	8	3433	42.5	206	17,975	137	58.9	8
36.1	1.07	3133	38.8	189	3,962	131	64.4	1.09
35.7	2.38	3233	39.2	191	7,582	133	63.8	2.42
35.6	4	3333	39.4	192	11,979	135	63.5	4
36.6	9	3433	38.2	185	17,953	137	65.4	9
39.6	1.18	3133	35.4	172	4,371	131	70.7	1.20
39.4	2.62	3233	35.5	173	7,634	133	70.4	2.67
41.0	5	3333	34.2	166	12,051	135	73.2	5
40.4	9	3433	34.6	168	17,929	137	72.2	10
45.8	1.36	3133	30.6	149	4,894	131	81.8	1.38
46.2	3.07	3233	30.3	148	7,706	133	82.5	3.04
46.3	5	3333	30.2	147	12,098	135	82.7	6
43.9	10	3433	31.9	155	17,908	137	78.4	10
51.4	1.52	3133	27.2	133	5,223	131	91.8	1.55
52.0	3.44	3233	26.9	131	7,755	133	92.8	3.34
50.4	6	3333	27.8	135	12,123	135	89.9	6
51.1	12	3433	27.4	133	17,869	137	91.2	12
57.4	1.69	3133	24.4	119	5,485	131	102	1.72
57.8	3.82	3233	24.2	118	7,792	133	103	3.61
57.0	7	3333	24.6	120	12,152	135	102	7

87Hz\* 400VY triangle-coupled motor supplied by drive

LS, LSES 1500 min <sup>-1</sup> - 50 Hz		Cb - Gearbox					LS, LSES 2600 min <sup>-1</sup> - 87 Hz	
N <sub>S</sub> (min <sup>-1</sup> )	Kp	Cb / MI-MU	i	M (Nm)	F <sub>R</sub> E/2 (N)	Dim. MI < ——— > page	N <sub>S</sub> (min <sup>-1</sup> )	Kp
<b>0.75 kW - 50 Hz</b>		<i>LSES 80 LG IFT/IE3</i> <i>LS 80 L FFB1 IFT/NIE - LSES 80 LG FFB1 IFT/IE3</i>					<b>1.31 kW - 87 Hz*</b>	
61.5	0.80	3032	22.8	111	2,197	127	110	0.82
65.5	1.93	3133	21.4	104	5,662	131	117	1.91
65.7	4	3233	21.3	104	7,833	133	117	3.93
64.0	8	3333	21.9	107	12,172	135	114	8
69.2	0.90	3032	20.2	99	2,303	127	124	0.92
69.3	2.04	3133	20.2	98	5,616	131	124	2.01
73.0	5	3233	19.2	93	7,763	133	130	4.22
71.3	8	3333	19.6	96	12,187	135	127	8
77.5	1.01	3032	18.1	88	2,398	127	138	1.02
82.3	2.41	3133	17	83	5,366	131	147	2.28
82.8	5	3233	16.9	82	7,480	133	148	5
77.4	9	3333	18.1	88	12,195	135	138	9
91.2	1.18	3032	15.4	75	2,477	127	163	1.20
87.4	2.55	3133	16	78	5,283	131	156	2.38
88.5	6	3233	15.8	77	7,332	133	158	5
87.2	10	3333	16.1	78	12,205	135	156	10
98.3	1.27	3032	14.2	69	2,517	127	176	1.29
98.6	2.87	3133	14.2	69	5,113	131	176	2.58
102	6	3233	13.7	67	7,027	133	182	5
100	12	3333	14	68	12,213	135	179	11
114	1.48	3032	12.2	60	2,531	127	204	1.49
113	3.20	3133	12.4	61	4,923	131	201	2.82
116	7	3233	12	59	6,753	133	208	6
112	7	3333	12.5	61	12,800	135	201	7
128	1.65	3032	10.9	53	2,555	127	229	1.67
128	3.52	3133	10.9	53	4,754	131	229	3.07
130	5	3233	10.8	53	6,495	133	231	5
126	8	3333	11.1	54	12,804	135	225	8
137	1.76	3032	10.2	50	2,541	127	245	1.78
134	2.78	3133	10.4	51	4,657	131	240	2.87
144	5	3233	9.72	47	6,296	133	257	5
141	8	3333	9.95	48	12,368	135	251	9
163	2.08	3032	8.59	42	2,528	127	291	2.10
159	3.31	3133	8.79	43	4,434	131	285	3.41
163	6	3233	8.57	42	6,054	133	292	6
153	9	3333	9.16	45	12,039	135	273	9
173	2.01	3231	8.08	40	2,541	117	310	2.08
172	2.18	3032	8.16	40	2,517	127	306	2.20
179	3.89	3331	7.83	39	4,794	119	319	4.01
185	5	3133	7.57	37	4,270	131	330	3.90
175	6	3233	8.02	39	5,934	133	312	7
173	8	3431	8.1	40	7,529	121	309	8
172	10	3333	8.14	40	11,586	135	307	11
202	2.35	3231	6.92	34	2,431	117	361	2.42
190	2.40	3032	7.38	36	2,501	127	339	2.42
191	3.96	3133	7.34	36	4,208	131	341	3.93
198	4	3331	7.08	35	4,643	119	353	4
201	7	3233	6.96	34	5,678	133	359	8
205	10	3431	6.83	33	7,126	121	366	10
198	12	3333	7.09	35	11,078	135	353	12

LS, LSES 1500 min <sup>-1</sup> - 50 Hz		Cb - Gearbox					LS, LSES 2600 min <sup>-1</sup> - 87 Hz	
N <sub>S</sub> (min <sup>-1</sup> )	Kp	Cb / MI-MU	i	M (Nm)	F <sub>R</sub> E/2 (N)	Dim. MI < ——— > page	N <sub>S</sub> (min <sup>-1</sup> )	Kp
<b>0.75 kW - 50 Hz</b>		<i>LSES 80 LG IFT/IE3</i> <i>LS 80 L FFB1 IFT/NIE - LSES 80 LG FFB1 IFT/IE3</i>					<b>1.31 kW - 87 Hz*</b>	
224	1.63	3131	6.25	31	1,634	115	400	1.68
222	2.58	3231	6.31	31	2,363	117	396	2.66
218	5	3133	6.42	31	4,049	131	389	4
221	5	3331	6.33	31	4,483	119	395	5
229	8	3233	6.1	30	5,451	133	410	9
228	11	3431	6.15	30	6,886	121	406	11
246	1.79	3131	5.69	28	1,612	115	439	1.84
245	2.85	3231	5.71	28	2,298	117	438	2.93
248	5	3133	5.65	28	3,893	131	442	4
255	6	3331	5.5	27	4,285	119	455	6
251	12	3431	5.57	27	6,666	121	449	12
285	2.07	3131	4.92	24	1,572	115	508	2.13
287	3.34	3231	4.88	24	2,190	117	513	3.44
288	6	3331	4.87	24	4,119	119	514	6
273	13	3431	5.13	25	6,490	121	487	13
319	2.32	3131	4.38	22	1,529	115	570	2.39
323	3.75	3231	4.33	21	2,115	117	577	3.87
313	7	3331	4.47	22	4,010	119	559	6
317	15	3431	4.41	22	6,174	121	567	16
343	0.80	3031	4.08	20	1,151	113	613	0.82
356	2.59	3131	3.93	19	1,505	115	636	2.67
359	4	3231	3.89	19	2,046	117	642	4
358	6	3133	3.91	19	3,485	131	639	5
354	8	3331	3.95	19	3,854	119	633	7
386	0.90	3031	3.63	18	1,132	113	690	0.92
407	2.96	3131	3.44	17	1,455	115	727	3.05
408	5	3231	3.43	17	1,965	117	729	5
377	6	3133	3.71	18	3,429	131	673	5
398	8	3331	3.52	17	3,713	119	710	7
433	1.01	3031	3.24	16	1,118	113	773	1.04
431	3.13	3131	3.25	16	1,438	115	769	3.22
454	5	3231	3.09	15	1,904	117	810	5
443	9	3331	3.16	16	3,581	119	791	8
509	1.18	3031	2.75	14	1,084	113	909	1.22
512	3.71	3131	2.74	13	1,387	115	913	3.78
515	6	3231	2.72	13	1,831	117	919	6
481	10	3331	2.91	14	3,489	119	859	9
549	1.28	3031	2.55	13	1,070	113	980	1.31
543	3.94	3131	2.58	13	1,356	115	969	3.78
550	6	3231	2.55	13	1,787	117	982	7
542	12	3331	2.58	13	3,353	119	968	11
639	1.48	3031	2.19	11	1,046	113	1141	1.53
613	4	3131	2.29	11	1,323	115	1094	4
634	7	3231	2.21	11	1,711	117	1132	7
622	12	3331	2.25	11	3,208	119	1111	10
716	1.66	3031	1.96	10	1,019	113	1278	1.71
700	5	3131	2	10	1,273	115	1250	4
723	8	3231	1.94	10	1,639	117	1290	8
767	1.78	3031	1.83	9	1,013	113	1369	1.84
795	5	3131	1.76	9	1,228	115	1420	4
910	2.11	3031	1.54	8	967	113	1625	2.18
958	2.22	3031	1.46	7	968	113	1711	2.29
1059	2.46	3031	1.32	7	932	113	1890	2.53
1149	6	3131	1.22	6	1,113	115	2051	5
1211	6	3131	1.16	6	1,093	115	2162	5

87Hz\* 400VY triangle-coupled motor supplied by drive

LS, LSES 1500 min <sup>-1</sup> - 50 Hz		Cb - Gearbox					LS, LSES 2600 min <sup>-1</sup> - 87 Hz	
N <sub>S</sub> (min <sup>-1</sup> )	Kp	Cb / MI-MU	i	M (Nm)	F <sub>R</sub> E/2 (N)	Dim. MI < ——— > page	N <sub>S</sub> (min <sup>-1</sup> )	Kp
<b>0.9 kW - 50 Hz</b>		<i>LSES 80 LG IFT/IE3</i> <i>LS 80 L FFB1 IFT/NIE - LSES 80 LG FFB1 IFT/IE3</i>					<b>1.57 kW - 87 Hz*</b>	
0.42	0.80	3835	3360	18478	36,581	147		
0.47	0.89	3835	3030	16641	39,504	147		
0.52	0.98	3835	2740	15066	41,707	147		
0.56	1.06	3835	2530	13881	43,179	147		
0.64	0.79	3735	2220	12239	20,275	147		
0.73	0.90	3735	1950	10774	23,728	147		
0.81	1.00	3735	1760	9701	26,259	147		
0.92	1.13	3735	1550	8547	28,977	147		
0.98	1.21	3735	1450	7999	30,270	147		
1.13	1.40	3735	1260	6940	32,767	147		
1.26	1.53	3735	1130	6321	34,226	147		
1.44	0.79	3635	988	5452	21,913	147		
1.47	1.79	3735	970	5413	36,366	147		
1.45	2.70	3835	983	5463	49,078	147		
1.60	0.86	3635	890	4965	23,280	147		
1.61	1.96	3735	885	4936	37,490	147		
1.72	3.20	3835	829	4609	49,229	147		
1.87	1.01	3635	762	4252	25,286	147		
1.78	2.17	3735	801	4472	38,584	147		
1.91	3.56	3835	747	4150	49,276	147		
2.05	1.11	3635	695	3878	26,339	147		
2.08	2.54	3735	684	3815	40,132	147		
2.11	3.93	3835	676	3757	49,298	147		
2.28	0.88	3535	625	3487	11,587	147	3.98	0.88
2.26	1.22	3635	630	3513	27,364	147		
2.34	2.86	3735	608	3391	41,132	147		
2.29	4	3835	623	3462	49,303	147		
2.41	0.93	3535	591	3297	12,787	147	4.21	0.93
2.65	1.43	3635	537	2997	28,815	147		
2.61	3.18	3735	546	3048	41,941	147		
2.86	1.11	3535	498	2776	16,077	147	5	1.11
2.98	1.61	3635	477	2664	29,751	147		
2.96	3.61	3735	481	2683	42,800	147		
3.04	1.17	3535	469	2616	17,087	147	5.31	1.18
3.32	1.79	3635	429	2394	30,510	147		
3.29	4	3735	433	2416	43,431	147		
3.43	1.33	3535	416	2319	18,963	147	5.99	1.33
3.77	2.03	3635	378	2108	31,315	147		
3.74	5	3735	381	2129	44,107	147		
4.08	0.82	3435	349	1968	3,438	147	7.14	0.82
3.92	1.52	3535	364	2029	20,794	147	6.85	1.52
4.19	2.26	3635	340	1898	31,906	147		
3.99	5	3735	357	1992	44,429	147		
4.45	1.72	3535	320	1785	22,334	147	7.78	1.72
4.76	2.56	3635	300	1672	32,540	147		
4.60	6	3735	310	1728	45,051	147		
5.08	2.74	3635	280	1565	32,842	147		
5.24	6	3735	272	1516	45,551	147		
5.90	1.18	3435	242	1362	11,275	147	10.3	1.18
6.22	1.24	3435	229	1293	12,040	147	10.9	1.24
6.24	2.41	3535	222	1274	25,561	147	10.9	2.42

87Hz\* 400VY triangle-coupled motor supplied by drive

LS, LSES 1500 min <sup>-1</sup> - 50 Hz		Cb - Gearbox					LS, LSES 2600 min <sup>-1</sup> - 87 Hz	
N <sub>s</sub> (min <sup>-1</sup> )	Kp	Cb / MI-MU	i	M (Nm)	F <sub>R</sub> E/2 (N)	Dim. MI < ——— > page	N <sub>s</sub> (min <sup>-1</sup> )	Kp
<b>0.9 kW - 50 Hz</b>		<i>LSES 80 LG IFT/IE3</i> <i>LS 80 L FFB1 IFT/NIE - LSES 80 LG FFB1 IFT/IE3</i>					<b>1.57 kW - 87 Hz*</b>	
6.99	1.40	3433	204	1160	13,394	137	12.2	1.40
7.87	0.81	3333	181	1032	2,391	135	13.8	0.81
8.28	1.66	3433	172	978	15,001	137	14.5	1.65
8.79	0.90	3333	162	924	4,412	135	15.4	0.91
9.19	1.85	3433	155	879	15,750	137	16.1	1.83
10.1	1.04	3333	141	802	6,402	135	17.7	1.04
10.2	2.04	3433	140	796	16,306	137	17.8	2.02
11.4	1.18	3333	125	710	7,718	135	20.0	1.18
11.0	2.21	3433	129	734	16,676	137	19.3	2.19
12.5	1.28	3333	114	652	8,450	135	21.8	1.28
12.8	2.56	3433	111	631	17,194	137	22.4	2.54
14.5	0.82	3233	98.2	560	1,188	133	25.4	0.82
14.1	1.45	3333	101	576	9,322	135	24.6	1.45
16.5	0.93	3233	86.5	493	2,094	133	28.8	0.93
15.8	1.63	3333	90.1	514	9,955	135	27.6	1.63
18.3	1.03	3233	77.9	444	2,989	133	32.0	1.03
17.6	1.81	3333	80.9	461	10,427	135	30.8	1.81
20.8	1.17	3233	68.6	391	4,081	133	36.3	1.16
19.1	1.97	3333	74.4	424	10,722	135	33.5	1.97
22.2	1.25	3233	64.2	366	4,624	133	38.8	1.24
21.6	2.22	3333	66.1	377	11,066	135	37.7	2.21
25.6	1.44	3233	55.7	317	5,673	133	44.7	1.43
24.8	2.54	3333	57.6	328	11,371	135	43.3	2.53
28.4	1.58	3233	50.2	289	6,266	133	49.6	1.56
29.3	2.88	3333	48.7	280	11,626	135	51.2	2.88
28.3	6	3433	50.3	289	18,006	137	49.5	5
33.2	1.84	3233	43	247	7,072	133	57.9	1.82
32.4	3.18	3333	44	253	11,751	135	56.6	3.19
33.6	7	3433	42.5	243	17,900	137	58.6	6.42
36.7	0.91	3133	38.8	224	3,043	131	64.1	0.90
36.4	2.01	3233	39.2	226	7,453	133	63.5	1.99
36.2	3.56	3333	39.4	227	11,859	135	63.3	3.56
37.3	7	3433	38.2	219	17,987	137	65.1	7
40.3	1.00	3133	35.4	204	3,589	131	70.4	0.99
40.1	2.22	3233	35.5	204	7,545	133	70.1	2.19
41.7	4	3333	34.2	197	11,963	135	72.9	4
41.2	8	3433	34.6	199	17,968	137	71.9	8
46.6	1.15	3133	30.6	176	4,285	131	81.5	1.14
47.0	2.59	3233	30.3	174	7,631	133	82.2	2.50
47.1	5	3333	30.2	174	12,031	135	82.3	5
44.7	9	3433	31.9	183	17,950	137	78.1	8
52.3	1.29	3133	27.2	157	4,720	131	91.4	1.27
52.9	2.91	3233	26.9	155	7,686	133	92.5	2.75
51.3	5	3333	27.8	160	12,068	135	89.6	5
52.0	10	3433	27.4	157	17,913	137	90.8	10
58.4	1.43	3133	24.4	141	5,065	131	102	1.41
58.9	3.23	3233	24.2	139	7,732	133	103	2.97
58.0	6	3333	24.6	141	12,111	135	101	6
66.7	1.63	3133	21.4	123	5,409	131	117	1.57
66.9	3.65	3233	21.3	123	7,778	133	117	3.24
65.1	6	3333	21.9	126	12,141	135	114	6

87Hz\* 400VY triangle-coupled motor supplied by drive

LS, LSES 1500 min <sup>-1</sup> - 50 Hz		Cb - Gearbox					LS, LSES 2600 min <sup>-1</sup> - 87 Hz	
N <sub>S</sub> (min <sup>-1</sup> )	Kp	Cb / MI-MU	i	M (Nm)	F <sub>R</sub> E/2 (N)	Dim. MI < ——— > page	N <sub>S</sub> (min <sup>-1</sup> )	Kp
<b>0.9 kW - 50 Hz</b>		<i>LSES 80 LG IFT/IE3</i> <i>LS 80 L FFB1 IFT/NIE - LSES 80 LG FFB1 IFT/IE3</i>					<b>1.57 kW - 87 Hz*</b>	
70.6	1.72	3133	20.2	116	5,462	131	123	1.65
74.3	4	3233	19.2	110	7,627	133	130	3.47
72.6	7	3333	19.6	113	12,163	135	127	7
78.9	0.85	3032	18.1	104	1,977	127	138	0.84
83.8	2.04	3133	17	98	5,233	131	146	1.88
84.3	4	3233	16.9	97	7,356	133	147	3.78
78.8	8	3333	18.1	104	12,176	135	138	7
92.8	1.00	3032	15.4	88	2,131	127	162	0.99
88.9	2.16	3133	16	92	5,157	131	155	1.95
90.1	5	3233	15.8	91	7,215	133	157	3.95
88.8	9	3333	16.1	92	12,191	135	155	8
100	1.08	3032	14.2	82	2,172	127	175	1.06
100	2.43	3133	14.2	82	4,996	131	175	2.12
104	5	3233	13.7	79	6,921	133	181	4
102	10	3333	14	81	12,203	135	178	9
117	1.25	3032	12.2	70	2,261	127	204	1.23
115	2.70	3133	12.4	72	4,820	131	200	2.32
118	6	3233	12	69	6,660	133	207	5
114	6	3333	12.5	72	12,810	135	200	6
130	1.39	3032	10.9	63	2,286	127	228	1.37
130	2.97	3133	10.9	63	4,658	131	228	2.53
132	4	3233	10.8	62	6,402	133	231	4
128	6	3333	11.1	64	12,684	135	224	6
140	1.49	3032	10.2	59	2,297	127	244	1.46
137	2.35	3133	10.4	60	4,563	131	239	2.36
147	4	3233	9.72	56	6,204	133	256	4
143	7	3333	9.95	57	12,254	135	250	7
166	1.76	3032	8.59	49	2,335	127	290	1.72
162	2.80	3133	8.79	51	4,349	131	283	2.8
166	5	3233	8.57	49	5,976	133	291	5
156	8	3333	9.16	53	11,932	135	272	8
176	1.70	3231	8.08	47	2,488	117	308	1.71
175	1.85	3032	8.16	47	2,324	127	305	1.81
182	3.29	3331	7.83	46	4,739	119	318	3.30
188	3.79	3133	7.57	44	4,198	131	329	3.21
178	5	3233	8.02	46	5,856	133	311	5
176	7	3431	8.1	47	7,464	121	307	6
175	9	3333	8.14	47	11,486	135	306	9
206	1.99	3231	6.92	40	2,383	117	360	1.99
193	2.03	3032	7.38	43	2,309	127	337	1.99
194	3.35	3133	7.34	42	4,139	131	339	3.23
201	3.64	3331	7.08	41	4,592	119	352	3.65
205	6	3233	6.96	40	5,608	133	358	6
209	8	3431	6.83	40	7,062	121	364	8
201	10	3333	7.09	41	10,986	135	351	10
228	1.38	3131	6.25	36	1,553	115	398	1.38
226	2.18	3231	6.31	37	2,315	117	395	2.18
222	3.83	3133	6.42	37	3,981	131	388	3.49
225	4	3331	6.33	37	4,433	119	393	4
233	7	3233	6.1	35	5,388	133	408	7
232	9	3431	6.15	36	6,827	121	405	9

87Hz\* 400VY triangle-coupled motor supplied by drive

Selection tables

Compabloc: Cb / LS, LSES motors / 4 poles

LS, LSES 1500 min <sup>-1</sup> - 50 Hz		Cb - Gearbox					LS, LSES 2600 min <sup>-1</sup> - 87 Hz	
N <sub>s</sub> (min <sup>-1</sup> )	Kp	Cb / MI-MU	i	M (Nm)	F <sub>R</sub> E/2 (N)	Dim. MI < ——— > page	N <sub>s</sub> (min <sup>-1</sup> )	Kp
<b>0.9 kW - 50 Hz</b>		<i>LSES 80 LG IFT/IE3</i> <i>LS 80 L FFB1 IFT/NIE - LSES 80 LG FFB1 IFT/IE3</i>					<b>1.57 kW - 87 Hz*</b>	
250	1.51	3131	5.69	33	1,531	115	437	1.51
249	2.41	3231	5.71	33	2,255	117	436	2.41
252	4	3133	5.65	33	3,833	131	441	3.63
259	5	3331	5.5	32	4,239	119	453	5
256	10	3431	5.57	32	6,611	121	447	10
290	1.75	3131	4.92	29	1,491	115	506	1.75
292	2.82	3231	4.88	28	2,154	117	511	2.83
293	5	3331	4.87	28	4,079	119	512	5
278	11	3431	5.13	30	6,436	121	485	11
325	1.96	3131	4.38	26	1,463	115	568	1.96
329	3.17	3231	4.33	25	2,078	117	575	3.18
319	6	3331	4.47	26	3,969	119	557	5
323	13	3431	4.41	26	6,125	121	564	13
363	2.19	3131	3.93	23	1,438	115	634	2.19
366	3.53	3231	3.89	23	2,010	117	639	3.54
364	5	3133	3.91	23	3,435	131	636	4
361	7	3331	3.95	23	3,814	119	630	6
415	2.50	3131	3.44	20	1,404	115	724	2.50
416	4	3231	3.43	20	1,935	117	726	4.02
384	5	3133	3.71	21	3,387	131	671	4
405	7	3331	3.52	20	3,677	119	707	6
440	0.85	3031	3.24	19	1,047	113	770	0.85
438	2.64	3131	3.25	19	1,386	115	766	2.65
462	4	3231	3.09	18	1,873	117	807	4
451	8	3331	3.16	18	3,551	119	788	6
518	1.00	3031	2.75	16	1,033	113	905	1.00
521	3.14	3131	2.74	16	1,337	115	910	3.11
524	5	3231	2.72	16	1,801	117	915	5
490	9	3331	2.91	17	3,454	119	856	7
559	1.08	3031	2.55	15	1,021	113	976	1.08
553	3.33	3131	2.58	15	1,319	115	966	3.11
560	5	3231	2.55	15	1,763	117	978	5
552	10	3331	2.58	15	3,325	119	964	9
651	1.26	3031	2.19	13	996	113	1137	1.26
623	3.76	3131	2.29	13	1,287	115	1089	3.33
645	6	3231	2.21	13	1,687	117	1128	6
633	10	3331	2.25	13	3,178	119	1107	8
728	1.41	3031	1.96	11	991	113	1273	1.41
713	4	3131	2	12	1,237	115	1245	3.50
735	7	3231	1.94	11	1,622	117	1285	6
780	1.51	3031	1.83	11	963	113	1364	1.51
810	4	3131	1.76	10	1,206	115	1415	3.66
926	1.79	3031	1.54	9	939	113	1619	1.79
975	1.88	3031	1.46	9	920	113	1704	1.89
1077	2.08	3031	1.32	8	905	113	1883	2.08
1169	5	3131	1.22	7	1,093	115	2043	4
1232	5	3131	1.16	7	1,072	115	2154	4

87Hz\* 400VY triangle-coupled motor supplied by drive



LS, LSES 1500 min <sup>-1</sup> - 50 Hz		Cb - Gearbox					LS, LSES 2600 min <sup>-1</sup> - 87 Hz	
N <sub>S</sub> (min <sup>-1</sup> )	Kp	Cb / MI-MU	i	M (Nm)	F <sub>R</sub> E/2 (N)	Dim. MI < ——— > page	N <sub>S</sub> (min <sup>-1</sup> )	Kp
<b>1.1 kW - 50 Hz</b>		LSES 90 SL IFT/IE3 LS 90 SL FFB2 IFT/NIE - LSES 90 SL FFB2 IFT/IE3					<b>1.91 kW - 87 Hz*</b>	
0.52	0.80	3835	2740	18482	36,575	147		
0.56	0.87	3835	2530	17028	38,919	147		
0.66	1.01	3835	2170	14635	42,261	147		
0.70	1.08	3835	2020	13637	43,462	147		
0.81	0.82	3735	1760	11891	21,096	147		
0.80	1.24	3835	1770	11942	45,247	147		
0.92	0.93	3735	1550	10477	24,428	147		
0.91	1.40	3835	1570	10555	46,466	147		
0.98	0.99	3735	1450	9805	26,013	147		
1.02	1.57	3835	1390	9399	47,316	147		
1.13	1.14	3735	1260	8506	29,074	147		
1.14	1.75	3835	1250	8421	47,917	147		
1.33	2.05	3835	1070	7206	48,513	147		
1.47	1.46	3735	970	6635	33,486	147		
1.45	2.20	3835	983	6701	48,712	147		
1.61	1.60	3735	885	6051	34,863	147		
1.72	2.61	3835	829	5653	49,033	147		
1.87	0.82	3635	762	5212	22,586	147		
1.78	1.77	3735	801	5481	36,204	147		
1.91	2.90	3835	747	5091	49,154	147		
2.05	0.90	3635	695	4753	23,877	147		
2.08	2.07	3735	684	4676	38,102	147		
2.11	3.20	3835	676	4609	49,229	147		
2.26	1.00	3635	630	4306	25,134	147		
2.34	2.33	3735	608	4157	39,327	147		
2.29	3.48	3835	623	4247	49,268	147		
2.65	1.17	3635	537	3674	26,912	147		
2.61	2.59	3735	546	3736	40,319	147		
2.66	4	3835	535	3650	49,301	147		
2.86	0.90	3535	498	3403	12,118	147	5.07	0.93
2.98	1.31	3635	477	3265	28,060	147		
2.96	2.95	3735	481	3289	41,373	147		
2.86	4	3835	499	3401	49,302	147		
3.04	0.96	3535	469	3207	13,355	147	5.39	0.98
3.32	1.46	3635	429	2935	28,990	147		
3.29	3.27	3735	433	2961	42,145	147		
3.26	5	3835	437	2978	49,289	147		
3.43	1.08	3535	416	2842	15,660	147	6.08	1.11
3.77	1.66	3635	378	2584	29,977	147		
3.74	3.71	3735	381	2609	42,975	147		
3.69	6	3835	386	2632	49,263	147		
3.92	1.24	3535	364	2487	17,902	147	6.94	1.27
4.19	1.84	3635	340	2326	30,701	147		
3.99	3.97	3735	357	2442	43,369	147		
4.14	6.3	3835	344	2344	49,231	147		
4.45	1.40	3535	320	2189	19,783	147	7.89	1.44
4.76	2.09	3635	300	2050	31,479	147		
4.60	5	3735	310	2118	44,132	147		
4.62	7	3835	308	2100	49,197	147		

87Hz\* 400VY triangle-coupled motor supplied by drive

LS, LSES 1500 min <sup>-1</sup> - 50 Hz		Cb - Gearbox					LS, LSES 2600 min <sup>-1</sup> - 87 Hz	
N <sub>S</sub> (min <sup>-1</sup> )	K <sub>p</sub>	Cb / MI-MU	i	M (Nm)	F <sub>R</sub> E/2 (N)	Dim. MI < ——— > page	N <sub>S</sub> (min <sup>-1</sup> )	K <sub>p</sub>
<b>1.1 kW - 50 Hz</b>		<i>LSES 90 SL IFT/IE3</i> <i>LS 90 SL FFB2 IFT/NIE - LSES 90 SL FFB2 IFT/IE3</i>					<b>1.91 kW - 87 Hz*</b>	
5.21	0.85	3435	273	1890	4,539	147	9.23	0.87
4.89	1.54	3535	283	1993	21,021	147	8.67	1.58
5.08	2.24	3635	280	1918	31,848	147		
5.24	5	3735	272	1859	44,744	147		
5.40	8	3835	264	1797	49,145	147		
5.90	0.96	3435	242	1670	7,529	147	10.5	0.99
5.52	1.74	3535	251	1767	22,448	147	9.77	1.79
5.66	2.52	3633 MI	252	1749	32,325	141		
5.85	6	3733	244	1687	45,148	143		
6.22	1.01	3435	229	1584	8,629	147	11.0	1.04
6.24	1.97	3535	222	1561	23,749	147	11.1	2.02
6.59	2.94	3633 MI	216	1501	33,022	141		
6.57	7	3733	217	1502	45,585	143		
6.99	1.15	3433	204	1422	10,597	137	12.4	1.17
7.08	2.21	3533	201	1398	24,778	139	12.5	2.25
7.17	3.19	3633 MI	199	1380	33,362	141		
7.20	7	3733	198	1370	45,896	143		
8.28	1.35	3433	172	1200	13,000	137	14.7	1.38
8.25	2.57	3533	173	1200	25,853	139	14.6	2.62
8.23	3.67	3633 MI	173	1202	33,862	141		
8.15	8	3733	175	1211	46,270	143		
9.19	1.50	3433	155	1079	14,144	137	16.3	1.53
8.97	2.79	3533	159	1103	25,867	139	15.9	2.84
9.33	4.16	3633 MI	153	1060	34,261	141		
10.1	0.85	3333	141	983	3,331	135	17.9	0.87
10.2	1.66	3433	140	977	15,013	137	18.0	1.69
10.3	3.20	3533	138	961	25,867	139	18.2	3.25
10.4	5	3633 MI	137	951	34,567	141		
11.4	0.96	3333	125	870	5,326	135	20.3	0.98
11.0	1.80	3433	129	900	15,602	137	19.5	1.83
11.7	3.62	3533	122	847	25,859	139	20.7	3.60
11.7	5	3633 MI	122	847	34,860	141		
12.5	1.04	3333	114	800	6,437	135	22.1	1.07
12.8	2.09	3433	111	773	16,445	137	22.7	2.12
13.0	4	3533	110	761	25,854	139	23.1	3.91
14.1	1.18	3333	101	706	7,761	135	25.0	1.21
13.8	2.24	3433	104	721	16,748	137	24.4	2.27
14.6	4.52	3533	97.5	677	25,854	139	25.9	4
15.8	1.33	3333	90.1	629	8,724	135	28.0	1.36
15.7	2.55	3433	90.7	631	17,191	137	27.9	2.59
18.3	0.84	3233	77.9	544	1,362	133	32.4	0.86
17.6	1.48	3333	80.9	565	9,444	135	31.2	1.51
17.8	2.88	3433	80.1	558	17,487	137	31.5	2.92
20.8	0.95	3233	68.6	479	2,325	133	36.8	0.97
19.1	1.61	3333	74.4	520	9,894	135	33.9	1.64
20.0	3.23	3433	71.4	497	17,684	137	35.4	3.27
22.2	1.02	3233	64.2	448	2,895	133	39.3	1.04
21.6	1.81	3333	66.1	462	10,419	135	38.2	1.85
22.3	3.59	3433	63.9	445	17,800	137	39.5	3.64

87Hz\* 400VY triangle-coupled motor supplied by drive

Selection tables

Compabloc: Cb / LS, LSES motors / 4 poles

LS, LSES 1500 min <sup>-1</sup> - 50 Hz		Cb - Gearbox					LS, LSES 2600 min <sup>-1</sup> - 87 Hz	
N <sub>S</sub> (min <sup>-1</sup> )	Kp	Cb / MI-MU	i	M (Nm)	F <sub>R</sub> E/2 (N)	Dim. MI < ——— > page	N <sub>S</sub> (min <sup>-1</sup> )	Kp
<b>1.1 kW - 50 Hz</b>		<i>LSES 90 SL IFT/IE3 LS 90 SL FFB2 IFT/NIE - LSES 90 SL FFB2 IFT/IE3</i>					<b>1.91 kW - 87 Hz*</b>	
25.6	1.17	3233	55.7	389	4,121	133	45.3	1.19
24.8	2.08	3333	57.6	402	10,887	135	43.9	2.11
26.1	4	3433	54.7	381	17,932	137	46.2	4
29.2	1.34	3233	48.9	341	5,157	133	51.7	1.36
29.3	2.35	3333	48.7	344	11,279	135	51.9	2.41
28.3	4	3433	50.3	354	17,965	137	50.2	5
28.7	9	3533	49.7	349	25,985	139	50.8	9
33.2	1.50	3233	43	303	5,969	133	58.8	1.52
32.4	2.60	3333	44	310	11,471	135	57.4	2.66
33.6	5	3433	42.5	299	18,004	137	59.5	5
33.4	10	3533	42.7	299	26,033	139	59.2	10
36.4	1.64	3233	39.2	277	6,515	133	64.4	1.66
36.2	2.90	3333	39.4	278	11,638	135	64.2	2.98
37.3	6	3433	38.2	269	18,007	137	66.0	6
36.3	11	3533	39.2	275	26,060	139	64.4	11
40.1	1.81	3233	35.5	251	7,014	133	71.1	1.83
41.7	3.34	3333	34.2	241	11,801	135	73.9	3.43
41.2	6	3433	34.6	244	18,001	137	72.9	7
41.7	12	3533	34.2	240	26,105	139	73.9	13
46.6	0.94	3133	30.6	216	3,266	131	82.6	0.95
47.0	2.11	3233	30.3	214	7,516	133	83.4	2.09
47.1	3.78	3333	30.2	213	11,907	135	83.5	3.87
44.7	7	3433	31.9	224	17,990	137	79.2	7
47.3	14	3533	30.1	211	26,100	139	83.8	14
52.3	1.05	3133	27.2	192	3,883	131	92.7	1.06
52.9	2.37	3233	26.9	190	7,585	133	93.8	2.29
51.3	4	3333	27.8	196	11,965	135	90.8	4
52.0	8	3433	27.4	193	17,962	137	92.1	8
52.7	16	3533	27.1	190	26,178	139	93.3	16
58.4	1.17	3133	24.4	172	4,370	131	103	1.18
58.9	2.63	3233	24.2	171	7,640	133	104	2.47
58.0	5	3333	24.6	173	12,033	135	103	5
55.8	9	3433	25.5	180	17,946	137	98.8	9
59.2	17	3533	24.1	169	26,212	139	105	17
66.7	1.33	3133	21.4	151	4,852	131	118	1.31
66.9	2.98	3233	21.3	150	7,700	133	119	2.69
65.1	5	3333	21.9	154	12,081	135	115	5
63.7	10	3433	22.4	157	17,913	137	113	10
70.6	1.41	3133	20.2	143	5,025	131	125	1.38
74.3	3.29	3233	19.2	135	7,498	133	132	2.89
72.6	6	3333	19.6	139	12,116	135	129	6
72.1	11	3433	19.8	139	17,881	137	128	11
83.8	1.66	3133	17	120	5,089	131	148	1.56
84.3	3.61	3233	16.9	119	7,242	133	149	3.15
78.8	6	3333	18.1	128	12,138	135	140	6
80.9	12	3433	17.6	124	17,850	137	143	12

87Hz\* 400VY triangle-coupled motor supplied by drive

LS, LSES 1500 min <sup>-1</sup> - 50 Hz		Cb - Gearbox					LS, LSES 2600 min <sup>-1</sup> - 87 Hz	
N <sub>S</sub> (min <sup>-1</sup> )	K <sub>p</sub>	Cb / MI-MU	i	M (Nm)	F <sub>R</sub> E/2 (N)	Dim. MI < ——— > page	N <sub>S</sub> (min <sup>-1</sup> )	K <sub>p</sub>
<b>1.1 kW - 50 Hz</b>		<i>LSES 90 SL IFT/IE3</i> <i>LS 90 SL FFB2 IFT/NIE - LSES 90 SL FFB2 IFT/IE3</i>					<b>1.91 kW - 87 Hz*</b>	
88.9	1.76	3133	16	113	5,020	131	158	1.63
90.1	3.78	3233	15.8	112	7,106	133	160	3.29
88.8	7	3333	16.1	113	12,162	135	157	7
90.3	14	3433	15.8	111	17,822	137	160	13
100	1.98	3133	14.2	100	4,878	131	178	1.76
104	4	3233	13.7	97	6,828	133	184	3.62
102	8	3333	14	99	12,183	135	181	7
106	16	3433	13.5	95	17,783	137	187	15
115	2.2	3133	12.4	88	4,715	131	203	1.93
118	5	3233	12	85	6,578	133	210	3.94
114	5	3333	12.5	88	12,803	135	203	5
130	2.42	3133	10.9	77	4,567	131	231	2.10
132	3.27	3233	10.8	76	6,319	133	234	3.36
128	5	3333	11.1	78	12,622	135	228	5
147	2.64	3133	9.67	68	4,421	131	261	2.28
147	3.64	3233	9.72	69	6,128	133	260	3.73
143	6	3333	9.95	70	12,197	135	254	6
166	2.86	3133	8.57	61	4,276	131	295	2.47
166	4	3233	8.57	60	5,911	133	295	4
156	6	3333	9.16	65	11,879	135	276	6
182	2.69	3331	7.83	56	4,700	119	322	2.76
188	3.09	3133	7.57	53	4,139	131	333	2.67
178	4	3233	8.02	57	5,792	133	315	5
176	5	3431	8.1	58	7,431	121	312	5
175	7	3333	8.14	57	11,442	135	310	7
178	10	3531	8	57	7,604	123	316	10
206	1.62	3231	6.92	49	2,335	117	365	1.66
194	2.73	3133	7.34	52	4,068	131	344	2.69
201	2.97	3331	7.08	50	4,557	119	357	3.05
205	5	3233	6.96	49	5,555	133	363	5
209	7	3431	6.83	49	7,036	121	370	7
201	8	3333	7.09	50	10,946	135	356	8
208	11	3531	6.87	49	7,236	123	368	11
208	19	3433	6.86	48	16,893	137	368	19
226	1.78	3231	6.31	45	2,272	117	400	1.83
222	3.12	3133	6.42	45	3,924	131	393	2.90
225	3.32	3331	6.33	45	4,401	119	399	3.41
233	6	3233	6.1	43	5,341	133	414	6
232	8	3431	6.15	44	6,802	121	410	8
226	13	3531	6.31	45	7,041	123	400	12
249	1.96	3231	5.71	41	2,211	117	442	2.01
252	3.49	3133	5.65	40	3,783	131	447	3.02
259	3.82	3331	5.5	39	4,211	119	459	3.91
256	8	3431	5.57	40	6,587	121	453	9
259	14	3531	5.5	39	6,732	123	459	14

LS, LSES 1500 min <sup>-1</sup> - 50 Hz		Cb - Gearbox					LS, LSES 2600 min <sup>-1</sup> - 87 Hz	
N <sub>S</sub> (min <sup>-1</sup> )	Kp	Cb / MI-MU	i	M (Nm)	F <sub>R</sub> E/2 (N)	Dim. MI < ——— > page	N <sub>S</sub> (min <sup>-1</sup> )	Kp
<b>1.1 kW - 50 Hz</b>		<i>LSES 90 SL IFT/IE3</i> <i>LS 90 SL FFB2 IFT/NIE - LSES 90 SL FFB2 IFT/IE3</i>					<b>1.91 kW - 87 Hz*</b>	
290	1.43	3131	4.92	35	1,409	115	514	1.46
292	2.30	3231	4.88	35	2,114	117	518	2.36
285	3.69	3133	4.99	35	3,654	131	506	3.13
293	4	3331	4.87	35	4,050	119	519	4
278	9	3431	5.13	36	6,417	121	492	9
294	16	3531	4.85	34	6,462	123	521	16
325	1.60	3131	4.38	31	1,393	115	576	1.64
329	2.59	3231	4.33	31	2,044	117	583	2.66
322	3.80	3133	4.43	31	3,530	131	570	3.23
319	5	3331	4.47	32	3,944	119	564	4
323	10	3431	4.41	31	6,108	121	572	11
327	18	3531	4.35	31	6,236	123	580	17
363	1.78	3131	3.93	28	1,369	115	643	1.83
366	2.88	3231	3.89	28	1,980	117	648	2.96
364	4	3133	3.91	28	3,399	131	645	3.59
361	5	3331	3.95	28	3,793	119	639	5
347	11	3431	4.11	29	5,969	121	614	12
368	20	3531	3.88	27	6,005	123	652	18
415	2.04	3131	3.44	25	1,334	115	735	2.09
416	3.27	3231	3.43	24	1,911	117	736	3.36
384	4	3133	3.71	26	3,351	131	680	3.69
405	6	3331	3.52	25	3,656	119	717	5
396	13	3431	3.6	26	5,714	121	701	13
438	2.16	3131	3.25	23	1,331	115	777	2.21
462	3.63	3231	3.09	22	1,849	117	818	3.73
451	6	3331	3.16	23	3,528	119	799	5
448	15	3431	3.18	23	5,488	121	794	15
521	2.56	3131	2.74	20	1,281	115	923	2.59
524	4	3231	2.72	19	1,781	117	928	4
490	7	3331	2.91	21	3,436	119	868	6
503	16	3431	2.83	20	5,285	121	891	16
553	2.72	3131	2.58	18	1,278	115	979	2.59
560	4	3231	2.55	18	1,744	117	992	5
552	8	3331	2.58	18	3,310	119	977	7
561	17	3431	2.54	18	5,098	121	995	17
623	3.07	3131	2.29	16	1,246	115	1105	2.77
645	5	3231	2.21	16	1,666	117	1143	5
633	8	3331	2.25	16	3,164	119	1122	7
656	19	3431	2.17	15	4,845	121	1162	19
713	3.39	3131	2	14	1,210	115	1263	2.91
735	6	3231	1.94	14	1,600	117	1303	5
810	3.58	3131	1.76	13	1,165	115	1435	3.04
916	3.73	3131	1.56	11	1,138	115	1623	3.17
1033	3.86	3131	1.38	10	1,102	115	1831	3.28
978	8	3331	1.46	10	2,748	119	1733	7
1169	4	3131	1.22	9	1,065	115	2072	3.51
1128	9	3331	1.26	9	2,620	119	1999	7
1232	4	3131	1.16	8	1,058	115	2184	3.63

87Hz\* 400VY triangle-coupled motor supplied by drive

LS, LSES 1500 min <sup>-1</sup> - 50 Hz		Cb - Gearbox					LS, LSES 2600 min <sup>-1</sup> - 87 Hz	
N <sub>S</sub> (min <sup>-1</sup> )	Kp	Cb / MI-MU	i	M (Nm)	F <sub>R</sub> E/2 (N)	Dim. MI < ——— > page	N <sub>S</sub> (min <sup>-1</sup> )	Kp
<b>1.5 kW - 50 Hz</b>		<i>LSES 90 LU IFT/IE3</i> <i>LS 90 L FFB2 IFT/NIE - LSES 90 LU FFB2 IFT/IE3</i>					<b>2.61 kW - 87 Hz*</b>	
0.71	0.79	3835	2020	18612	36,352	147		
0.81	0.91	3835	1770	16298	40,007	147		
0.91	1.03	3835	1570	14405	42,547	147		
1.03	1.15	3835	1390	12828	44,356	147		
1.14	0.84	3735	1260	11599	21,784	147		
1.15	1.29	3835	1250	11493	45,666	147		
1.34	1.50	3835	1070	9835	47,013	147		
1.47	1.07	3735	970	9047	27,800	147		
1.45	1.61	3835	983	9146	47,481	147		
1.62	1.17	3735	885	8250	29,678	147		
1.72	1.91	3835	829	7716	48,283	147		
1.78	1.30	3735	801	7474	31,507	147		
1.91	2.13	3835	747	6949	48,618	147		
2.09	1.52	3735	684	6376	34,095	147		
2.11	2.35	3835	676	6291	48,852	147		
2.35	1.71	3735	608	5668	35,765	147		
2.30	2.55	3835	623	5796	48,996	147		
2.66	0.86	3635	537	5009	23,157	147		
2.62	1.90	3735	546	5094	37,117	147		
2.67	2.96	3835	535	4982	49,173	147		
3.00	0.96	3635	477	4453	24,722	147		
2.97	2.16	3735	481	4484	38,554	147		
2.87	3.18	3835	499	4642	49,225	147		
3.33	1.07	3635	429	4002	25,989	147		
3.30	2.40	3735	433	4038	39,607	147		
3.27	3.63	3835	437	4065	49,282	147		
3.44	0.79	3535	416	3876	9,131	147	6.06	0.81
3.79	1.22	3635	378	3523	27,336	147		
3.75	2.72	3735	381	3558	40,739	147		
3.70	4	3835	386	3593	49,302	147		
3.93	0.91	3535	364	3391	12,194	147	6.93	0.92
4.20	1.35	3635	340	3172	28,323	147		
4.01	2.91	3735	357	3329	41,277	147		
4.16	5	3835	344	3199	49,299	147		
4.47	1.03	3535	320	2984	14,763	147	7.88	1.05
4.77	1.53	3635	300	2795	29,383	147		
4.62	3.36	3735	310	2888	42,316	147		
4.64	5	3835	308	2866	49,282	147		
4.91	1.13	3535	283	2717	16,449	147	8.65	1.15
5.10	1.64	3635	280	2616	29,888	147		
5.26	3.82	3735	272	2534	43,151	147		
5.42	6	3835	264	2453	49,245	147		
5.54	1.28	3535	251	2409	18,394	147	9.75	1.30
5.68	1.85	3633 MI	252	2388	30,527	141		
5.87	4	3733 MI	244	2306	43,689	143		

87Hz\* 400VY triangle-coupled motor supplied by drive

LS, LSES 1500 min <sup>-1</sup> - 50 Hz		Cb - Gearbox					LS, LSES 2600 min <sup>-1</sup> - 87 Hz	
N <sub>S</sub> (min <sup>-1</sup> )	Kp	Cb / MI-MU	i	M (Nm)	F <sub>R</sub> E/2 (N)	Dim. MI < ——— > page	N <sub>S</sub> (min <sup>-1</sup> )	Kp
<b>1.5 kW - 50 Hz</b>		<i>LSES 90 LU IFT/IE3</i> <i>LS 90 L FFB2 IFT/NIE - LSES 90 LU FFB2 IFT/IE3</i>					<b>2.61 kW - 87 Hz*</b>	
6.26	1.44	3535	222	2129	20,162	147	11.0	1.47
6.61	2.15	3633 MI	216	2050	31,478	141		
6.59	5	3733 MI	217	2052	44,287	143		
7.01	0.84	3433	204	1940	3,831	137	12.4	0.85
7.10	1.62	3533	201	1909	21,551	139	12.5	1.63
7.19	2.34	3633 MI	199	1885	31,943	141		
7.23	5	3733 MI	198	1872	44,712	143		
8.31	0.99	3433	172	1637	7,963	137	14.6	1.00
8.27	1.88	3533	173	1639	23,256	139	14.6	1.90
8.26	2.68	3633 MI	173	1642	32,625	141		
8.18	6	3733 MI	175	1655	45,223	143		
9.23	1.10	3433	155	1472	10,003	137	16.3	1.11
9.00	2.05	3533	159	1506	24,096	139	15.9	2.06
9.36	3.04	3633 MI	153	1448	33,171	141		
10.2	1.22	3433	140	1333	11,601	137	18.0	1.23
10.3	2.34	3533	138	1312	25,321	139	18.2	2.36
10.4	3.39	3633 MI	137	1300	33,588	141		
11.1	1.32	3433	129	1228	12,712	137	19.5	1.33
11.7	2.65	3533	122	1157	25,861	139	20.6	2.61
11.7	3.80	3633 MI	122	1157	33,989	141		
12.9	1.53	3433	111	1056	14,350	137	22.7	1.54
13.1	2.95	3533	110	1039	25,869	139	23.0	2.84
14.1	0.87	3333	101	963	3,698	135	24.9	0.88
13.8	1.64	3433	104	984	14,957	137	24.3	1.65
14.7	3.31	3533	97.5	925	25,865	139	25.8	3.07
15.9	0.97	3333	90.1	858	5,516	135	28.0	0.99
15.8	1.87	3433	90.7	861	15,876	137	27.8	1.88
17.7	1.08	3333	80.9	770	6,874	135	31.2	1.10
17.9	2.11	3433	80.1	761	16,517	137	31.5	2.12
19.2	1.18	3333	74.4	709	7,727	135	33.9	1.19
20.0	2.36	3433	71.4	678	16,971	137	35.3	2.37
21.6	1.33	3333	66.1	630	8,723	135	38.1	1.34
22.4	2.63	3433	63.9	607	17,294	137	39.4	2.64
25.7	0.86	3233	55.7	531	1,529	133	45.2	0.87
24.8	1.52	3333	57.6	548	9,613	135	43.8	1.54
26.1	3.07	3433	54.7	520	17,615	137	46.1	3.07
29.3	0.98	3233	48.9	465	2,573	133	51.6	0.99
29.4	1.72	3333	48.7	468	10,362	135	51.8	1.75
28.4	3.29	3433	50.3	483	17,722	137	50.1	3.30
28.8	6	3533	49.7	476	25,901	139	50.7	6
33.3	1.10	3233	43	414	3,599	133	58.6	1.11
32.5	1.90	3333	44	423	10,730	135	57.3	1.94
33.7	3.89	3433	42.5	408	17,890	137	59.3	3.89
33.5	7	3533	42.7	409	25,938	139		



LS, LSES 1500 min <sup>-1</sup> - 50 Hz		Cb - Gearbox					LS, LSES 2600 min <sup>-1</sup> - 87 Hz	
N <sub>S</sub> (min <sup>-1</sup> )	K <sub>p</sub>	Cb / MI-MU	i	M (Nm)	F <sub>R</sub> E/2 (N)	Dim. MI < ——— > page	N <sub>S</sub> (min <sup>-1</sup> )	K <sub>p</sub>
<b>1.5 kW - 50 Hz</b>		<i>LSES 90 LU IFT/IE3</i> <i>LS 90 L FFB2 IFT/NIE - LSES 90 LU FFB2 IFT/IE3</i>					<b>2.61 kW - 87 Hz*</b>	
36.5	1.20	3233	39.2	377	4,377	133	64.3	1.21
36.3	2.13	3333	39.4	379	11,052	135	64.0	2.16
37.4	4	3433	38.2	367	17,950	137	65.9	4
36.5	8	3533	39.2	376	25,962	139	64.2	8
40.3	1.33	3233	35.5	342	5,149	133	71.0	1.33
41.8	2.45	3333	34.2	329	11,366	135	73.7	2.49
41.3	5	3433	34.6	332	17,985	137	72.8	5
41.8	9	3533	34.2	327	26,004	139		
47.2	1.55	3233	30.3	292	6,214	133	83.2	1.52
47.3	2.77	3333	30.2	291	11,573	135	83.3	2.82
44.8	5	3433	31.9	306	18,001	137	79.0	5
47.5	10	3533	30.1	289	26,044	139	83.6	10
53.1	1.74	3233	26.9	259	6,855	133	93.6	1.66
51.4	3.01	3333	27.8	268	11,686	135	90.7	3.06
52.2	6	3433	27.4	263	18,007	137	91.9	6
52.9	11	3533	27.1	259	26,080	139	93.2	11
58.6	0.86	3133	24.4	235	2,717	131	103	0.86
59.1	1.93	3233	24.2	233	7,330	133	104	1.80
58.2	3.41	3333	24.6	236	11,821	135	103	3.44
56.0	6	3433	25.5	245	18,002	137	99	6
59.4	13	3533	24.1	231	26,117	139		
66.9	0.98	3133	21.4	206	3,538	131	118	0.95
67.1	2.18	3233	21.3	205	7,419	133	118	1.96
65.3	3.83	3333	21.9	211	11,917	135	115	4
63.9	7	3433	22.4	215	17,983	137	113	7
70.8	1.03	3133	20.2	194	3,830	131	125	1.00
74.5	2.41	3233	19.2	185	7,230	133	131	2.10
72.8	4	3333	19.6	189	11,988	135	128	4
72.3	8	3433	19.8	190	17,958	137	127	8
84.1	1.22	3133	17	164	4,569	131	148	1.14
84.6	2.64	3233	16.9	163	7,006	133	149	2.29
79.1	5	3333	18.1	174	12,031	135	139	4
81.2	9	3433	17.6	169	17,931	137	143	9
89.2	1.29	3133	16	154	4,745	131	157	1.18
90.4	2.77	3233	15.8	152	6,891	133	159	2.39
89.1	5	3333	16.1	155	12,081	135	157	5
90.7	10	3433	15.8	151	17,903	137	160	10
101	1.45	3133	14.2	137	4,629	131	177	1.28
104	3.07	3233	13.7	132	6,639	133	184	2.63
102	6	3333	14	135	12,125	135	180	5
106	12	3433	13.5	130	17,862	137	187	11
115	1.62	3133	12.4	120	4,500	131	203	1.40
119	3.34	3233	12	116	6,409	133	209	2.87
115	3.41	3333	12.5	120	12,773	135	202	3.47

87Hz\* 400VY triangle-coupled motor supplied by drive

LS, LSES 1500 min <sup>-1</sup> - 50 Hz		Cb - Gearbox					LS, LSES 2600 min <sup>-1</sup> - 87 Hz	
N <sub>S</sub> (min <sup>-1</sup> )	Kp	Cb / MI-MU	i	M (Nm)	F <sub>R</sub> E/2 (N)	Dim. MI < ——— > page	N <sub>S</sub> (min <sup>-1</sup> )	Kp
<b>1.5 kW - 50 Hz</b>		<i>LSES 90 LU IFT/IE3</i> <i>LS 90 L FFB2 IFT/NIE - LSES 90 LU FFB2 IFT/IE3</i>					<b>2.61 kW - 87 Hz*</b>	
131	1.77	3133	10.9	105	4,377	131	230	1.53
132	2.40	3233	10.8	104	6,147	133	233	2.44
129	3.83	3333	11.1	107	12,480	135	227	3.89
148	1.93	3133	9.67	93	4,252	131	261	1.66
147	2.67	3233	9.72	94	5,973	133	259	2.71
144	4	3333	9.95	96	12,069	135	253	4
167	2.09	3133	8.57	82	4,133	131	294	1.80
167	3.03	3233	8.57	82	5,774	133	294	3.08
156	5	3333	9.16	88	11,764	135		
183	1.97	3331	7.83	76	4,618	119	322	2.00
189	2.26	3133	7.57	73	4,003	131	333	1.94
178	3.23	3233	8.02	77	5,667	133	314	3.29
177	3.94	3431	8.1	79	7,361	121		
176	5	3333	8.14	78	11,336	135		
179	7	3531	8	77	7,551	123		
207	1.19	3231	6.92	67.3	2,235	117	364	1.21
195	2.00	3133	7.34	70.6	3,927	131	343	1.96
202	2.18	3331	7.08	68.8	4,478	119	356	2.22
206	3.73	3233	6.96	67.0	5,442	133	362	3.79
209	5	3431	6.83	66.3	6,977	121		
202	6	3333	7.09	68.2	10,855	135		
208	8	3531	6.87	66.5	7,189	123		
208	14	3433	6.86	65.9	16,804	137		
227	1.30	3231	6.31	61.3	2,180	117	400	1.33
223	2.29	3133	6.42	61.8	3,798	131	392	2.11
226	2.44	3331	6.33	61.6	4,329	119	398	2.48
234	4	3233	6.1	58.7	5,240	133		
232	6	3431	6.15	59.7	6,746	121		
227	9	3531	6.31	61.1	6,996	123		
250	1.44	3231	5.71	55.6	2,126	117	441	1.46
253	2.56	3133	5.65	54.4	3,678	131	446	2.19
260	2.80	3331	5.5	53.5	4,150	119	458	2.84
257	6	3431	5.57	54.0	6,536	121		
260	11	3531	5.5	53.2	6,692	123		
291	1.05	3131	4.92	47.8	843	115	513	1.06
293	1.69	3231	4.88	47.4	2,043	117	517	1.72
286	2.70	3133	4.99	48.1	3,557	131	505	2.28
294	3.17	3331	4.87	47.3	3,996	119	518	3.13
279	7	3431	5.13	49.8	6,366	121		
295	12	3531	4.85	46.9	6,423	123		
326	1.17	3131	4.38	42.6	1,023	115	575	1.19
330	1.90	3231	4.33	42.1	1,977	117	582	1.93
323	2.78	3133	4.43	42.6	3,440	131	569	2.35
320	3.45	3331	4.47	43.5	3,890	119	563	3.21
324	8	3431	4.41	42.8	6,063	121		
329	13	3531	4.35	42.1	6,202	123		

LS, LSES 1500 min <sup>-1</sup> - 50 Hz		Cb - Gearbox					LS, LSES 2600 min <sup>-1</sup> - 87 Hz	
N <sub>S</sub> (min <sup>-1</sup> )	K <sub>p</sub>	Cb / MI-MU	i	M (Nm)	F <sub>R</sub> E/2 (N)	Dim. MI < ——— > page	N <sub>S</sub> (min <sup>-1</sup> )	K <sub>p</sub>
<b>1.5 kW - 50 Hz</b>		<i>LSES 90 LU IFT/IE3</i> <i>LS 90 L FFB2 IFT/NIE - LSES 90 LU FFB2 IFT/IE3</i>					<b>2.61 kW - 87 Hz*</b>	
364	1.31	3131	3.93	38.2	1,214	115	641	1.33
367	2.11	3231	3.89	37.9	1,919	117	647	2.15
365	3.10	3133	3.91	37.7	3,324	131	644	2.61
362	3.90	3331	3.95	38.4	3,746	119		
348	8	3431	4.11	39.9	5,927	121		
369	14	3531	3.88	37.5	5,970	123		
416	1.50	3131	3.44	33.4	1,221	115	733	1.52
417	2.40	3231	3.43	33.3	1,853	117	735	2.44
385	3.19	3133	3.71	35.7	3,276	131	679	2.69
406	4	3331	3.52	34.2	3,612	119		
397	9	3431	3.6	34.9	5,677	121		
440	1.58	3131	3.25	31.6	1,204	115	775	1.61
463	2.67	3231	3.09	30.0	1,796	117	816	2.71
453	4	3331	3.16	30.7	3,488	119		
449	11	3431	3.18	30.9	5,454	121		
523	1.88	3131	2.74	26.6	1,182	115	921	1.88
526	3.02	3231	2.72	26.5	1,734	117	926	3.08
492	5	3331	2.91	28.3	3,400	119		
505	12	3431	2.83	27.5	5,254	121		
554	1.99	3131	2.58	25.1	1,179	115	977	1.88
562	3.23	3231	2.55	24.8	1,696	117	990	3.29
554	6	3331	2.58	25.1	3,273	119		
563	13	3431	2.54	24.6	5,066	121		
626	2.25	3131	2.29	22.2	1,160	115	1103	2.01
648	3.73	3231	2.21	21.5	1,630	117	1141	3.61
636	6	3331	2.25	21.9	3,130	119		
658	14	3431	2.17	21.1	4,816	121		
715	2.48	3131	2	19.5	1,139	115	1260	2.12
738	4	3231	1.94	18.8	1,562	117		
813	2.63	3131	1.76	17.1	1,107	115	1432	2.21
919	2.73	3131	1.56	15.1	1,081	115	1620	2.30
1037	2.83	3131	1.38	13.4	1,058	115	1827	2.39
981	6	3331	1.46	14.2	2,722	119		
1173	3.03	3131	1.22	11.9	1,022	115	2068	2.56
1132	6	3331	1.26	12.3	2,598	119		
1237	3.13	3131	1.16	11.2	1,015	115	2179	2.64

Selection tables

Compabloc: Cb / LS, LSES motors / 4 poles

LS, LSES 1500 min <sup>-1</sup> - 50 Hz		Cb - Gearbox					LS, LSES 2600 min <sup>-1</sup> - 87 Hz	
N <sub>S</sub> (min <sup>-1</sup> )	Kp	Cb / MI-MU	i	M (Nm)	F <sub>R</sub> E/2 (N)	Dim. MI < — > page	N <sub>S</sub> (min <sup>-1</sup> )	Kp
<b>1.8 kW - 50 Hz</b>		LS 90 L FFB2 IFT/NIE - LSES 100 L FFB2 IFT/IE3					<b>3.13 kW - 87 Hz*</b>	
0.92	0.86	3835	1570	17260	38,561	147		
1.03	0.96	3835	1390	15370	41,304	147		
1.15	1.07	3835	1250	13770	43,309	147		
1.34	1.25	3835	1070	11785	45,396	147		
1.48	0.89	3735	970	10835	23,584	147		
1.46	1.35	3835	983	10959	46,133	147		
1.62	0.98	3735	885	9881	25,833	147		
1.73	1.60	3835	829	9245	47,417	147		
1.79	1.08	3735	801	8952	28,024	147		
1.92	1.77	3835	747	8326	47,970	147		
2.10	1.27	3735	684	7637	31,123	147		
2.12	1.96	3835	676	7538	48,367	147		
2.36	1.43	3735	608	6788	33,124	147		
2.30	2.13	3835	623	6945	48,619	147		
2.63	1.59	3735	546	6101	34,743	147		
2.68	2.47	3835	535	5969	48,949	147		
3.01	0.80	3635	477	5333	22,247	147		
2.98	1.80	3735	481	5371	36,464	147		
2.88	2.66	3835	499	5562	49,055	147		
3.34	0.89	3635	429	4793	23,765	147		
3.31	2.00	3735	433	4836	37,726	147		
3.28	3.03	3835	437	4871	49,191	147		
3.80	1.02	3635	378	4219	25,378	147		
3.76	2.27	3735	381	4261	39,081	147		
3.72	3.43	3835	386	4305	49,263	147		
4.22	1.13	3635	340	3799	26,560	147		
4.02	2.43	3735	357	3988	39,725	147		
4.17	3.85	3835	344	3833	49,295	147		
4.48	0.86	3535	320	3574	11,038	147	7.91	0.87
4.79	1.28	3635	300	3347	27,830	147		
4.63	2.80	3735	310	3459	40,970	147		
4.66	4	3835	308	3434	49,303	147		
4.93	0.94	3535	283	3254	13,059	147	8.68	0.96
5.12	1.37	3635	280	3133	28,434	147		
5.28	3.19	3735	272	3035	41,970	147		
5.44	5	3835	264	2939	49,287	147		
5.55	1.07	3535	251	2886	15,382	147	9.79	1.08
5.70	1.54	3633	252	2863	29,193	141		
5.89	3.65	3733	244	2765	42,607	143		
6.29	1.21	3535	222	2550	17,504	147	11.1	1.22
6.64	1.79	3633*	216	2457	30,333	141		
6.62	4.10	3733*	217	2461	43,324	143		

Cb 3633\*, Cb 3733\*: MI, compulsory integral mounting for frame 90

87Hz\* 400VY triangle-coupled motor supplied by drive

LS, LSES 1500 min <sup>-1</sup> - 50 Hz		Cb - Gearbox					LS, LSES 2600 min <sup>-1</sup> - 87 Hz	
N <sub>S</sub> (min <sup>-1</sup> )	K <sub>p</sub>	Cb / MI-MU	i	M (Nm)	F <sub>R</sub> E/2 (N)	Dim. MI < — — — > page	N <sub>S</sub> (min <sup>-1</sup> )	K <sub>p</sub>
<b>1.8 kW - 50 Hz</b>		LSES 100 L IFT/IE3 LS 90 L FFB2 IFT/NIE - LSES 100 L FFB2 IFT/IE3					<b>3.13 kW - 87 Hz*</b>	
7.13	1.35	3533	201	2288	19,158	139	12.6	1.36
7.22	1.95	3633*	199	2259	30,891	141		
7.25	5	3733*	198	2245	43,834	143		
8.34	0.83	3433	172	1961	3,536	137	14.7	0.83
8.30	1.57	3533	173	1964	21,204	139	14.6	1.58
8.29	2.24	3633*	173	1968	31,708	141		
8.20	5	3733*	175	1984	44,447	143		
9.26	0.92	3433	155	1764	6,276	137	16.3	0.92
9.03	1.71	3533	159	1806	22,202	139	15.9	1.71
9.40	2.54	3633*	153	1735	32,362	141		
10.2	1.01	3433	140	1597	8,466	137	18.0	1.02
10.4	1.95	3533	138	1573	23,673	139	18.3	1.96
10.5	2.83	3633*	137	1558	32,862	141		
11.1	1.10	3433	129	1472	10,012	137	19.6	1.10
11.8	2.21	3533	122	1387	24,848	139	20.7	2.17
11.8	3.17	3633*	122	1387	33,343	141		
12.9	1.28	3433	111	1265	12,334	137	22.8	1.28
13.1	2.46	3533	110	1245	25,744	139	23.1	2.36
13.9	1.37	3433	104	1179	13,208	137	24.4	1.37
14.7	2.76	3533	97.5	1108	25,867	139	25.9	2.55
15.9	0.81	3333	90.1	1028	2,468	135	28.1	0.82
15.8	1.56	3433	90.7	1032	14,554	137	27.9	1.56
17.8	0.91	3333	80.9	922	4,431	135	31.3	0.92
17.9	1.76	3433	80.1	912	15,512	137	31.6	1.76
19.3	0.98	3333	74.4	849	5,664	135	34.0	0.99
20.1	1.97	3433	71.4	812	16,204	137	35.5	1.98
21.7	1.11	3333	66.1	754	7,106	135	38.3	1.12
22.5	2.2	3433	63.9	728	16,709	137	39.6	2.20
24.9	1.27	3333	57.6	657	8,396	135	43.9	1.28
26.2	2.56	3433	54.7	623	17,228	137	46.2	2.56
29.4	0.82	3233	48.9	557	1,211	133	51.8	0.82
29.5	1.44	3333	48.7	561	9,482	135	52.0	1.46
28.5	2.75	3433	50.3	579	17,408	137	50.3	2.75
28.9	5	3533	49.7	571	25,869	139	50.9	5
33.4	0.92	3233	43	495	2,050	133	58.9	0.92
32.6	1.59	3333	44	507	10,017	135	57.5	1.61
33.8	3.24	3433	42.5	488	17,707	137	59.6	3.24
33.6	6	3533	42.7	490	25,895	139	59.3	6
36.6	1.01	3233	39.2	452	2,831	133	64.5	1.01
36.5	1.78	3333	39.4	454	10,487	135	64.3	1.80
37.5	3.59	3433	38.2	440	17,827	137	66.2	3.58
36.6	7	3533	39.2	450	25,914	139	64.5	7

Cb 3633\*, Cb 3733\*: MI, compulsory integral mounting for frame 90

Selection tables

Compabloc: Cb / LS, LSES motors / 4 poles

LS, LSES 1500 min <sup>-1</sup> - 50 Hz		Cb - Gearbox					LS, LSES 2600 min <sup>-1</sup> - 87 Hz	
N <sub>S</sub> (min <sup>-1</sup> )	Kp	Cb / MI-MU	i	M (Nm)	F <sub>R</sub> E/2 (N)	Dim. MI < ——— > page	N <sub>S</sub> (min <sup>-1</sup> )	Kp
<b>1.8 kW - 50 Hz</b>		<i>LSES 100 L IFT/IE3</i> <i>LS 90 L FFB2 IFT/NIE - LSES 100 L FFB2 IFT/IE3</i>					<b>3.13 kW - 87 Hz*</b>	
40.4	1.11	3233	35.5	409	3,690	133	71.3	1.11
42.0	2.05	3333	34.2	394	10,946	135	74.0	2.07
41.5	3.96	3433	34.6	398	17,906	137	73.1	3.94
42.0	8	3533	34.2	392	25,950	139	74.0	8
47.4	1.29	3233	30.3	349	4,987	133	83.5	1.26
47.5	2.31	3333	30.2	349	11,248	135	83.7	2.34
45.0	4	3433	31.9	367	17,951	137	79.3	4
47.6	9	3533	30.1	346	25,987	139	83.9	9
53.3	1.45	3233	26.9	310	5,821	133	94.0	1.38
51.6	2.51	3333	27.8	320	11,415	135	91.0	2.55
52.3	5	3433	27.4	315	17,996	137	92.3	5
53.1	10	3533	27.1	311	26,021	139	93.5	9
59.3	1.61	3233	24.2	279	6,468	133	105	1.49
58.4	2.85	3333	24.6	283	11,612	135	103	2.86
56.2	5	3433	25.5	294	18,005	137	99.0	5
59.6	11	3533	24.1	277	26,059	139		
67.2	0.81	3133	21.4	246	2,380	131	118	0.79
67.4	1.82	3233	21.3	246	7,106	133	119	1.63
65.6	3.19	3333	21.9	252	11,755	135	116	3.13
64.1	6	3433	22.4	257	18,006	137	113	6
71.1	0.86	3133	20.2	233	2,780	131	125	0.83
74.8	2.01	3233	19.2	221	7,035	133	132	1.75
73.1	3.56	3333	19.6	226	11,860	135	129	3.39
72.6	7	3433	19.8	227	17,992	137	128	7
84.4	1.02	3133	17	196	3,788	131	149	0.94
84.9	2.21	3233	16.9	195	6,832	133	150	1.90
79.4	3.87	3333	18.1	208	11,925	135	140	3.63
81.5	8	3433	17.6	203	17,972	137	144	7
89.5	1.08	3133	16	185	4,072	131	158	0.98
90.7	2.31	3233	15.8	182	6,727	133	160	1.99
89.4	4	3333	16.1	185	12,000	135	158	3.96
91.0	8	3433	15.8	181	17,948	137	160	8
101	1.21	3133	14.2	164	4,446	131	178	1.07
105	2.56	3233	13.7	158	6,497	133	184	2.19
103	5	3333	14	161	12,065	135	181	4.41
106	10	3433	13.5	155	17,909	137	187	9
115	1.35	3133	12.4	143	4,343	131	204	1.17
119	2.78	3233	12	139	6,283	133	210	2.38
115	2.85	3333	12.5	144	12,734	135	203	2.89

87Hz\* 400VY triangle-coupled motor supplied by drive

LS, LSES 1500 min <sup>-1</sup> - 50 Hz		Cb - Gearbox					LS, LSES 2600 min <sup>-1</sup> - 87 Hz	
N <sub>S</sub> (min <sup>-1</sup> )	Kp	Cb / MI-MU	i	M (Nm)	F <sub>R</sub> E/2 (N)	Dim. MI < ——— > page	N <sub>S</sub> (min <sup>-1</sup> )	Kp
<b>1.8 kW - 50 Hz</b>		<i>LSES 100 L IFT/IE3</i> <i>LS 90 L FFB2 IFT/NIE - LSES 100 L FFB2 IFT/IE3</i>					<b>3.13 kW - 87 Hz*</b>	
131	1.48	3133	10.9	126	4,234	131	231	1.27
133	2.00	3233	10.8	124	6,021	133	234	2.03
129	3.19	3333	11.1	128	12,373	135	228	3.24
148	1.61	3133	9.67	111	4,128	131	262	1.38
148	2.23	3233	9.72	112	5,860	133	260	2.26
144	3.56	3333	9.95	115	11,970	135	254	3.61
167	1.74	3133	8.57	99	4,016	131	295	1.49
167	2.53	3233	8.57	99	5,667	133	295	2.56
157	3.87	3333	9.16	106	11,670	135	276	3.92
183	1.64	3331	7.83	91	4,555	119	323	1.67
189	1.89	3133	7.57	87	3,906	131	334	1.62
179	2.70	3233	8.02	92	5,571	133	316	2.74
177	3.29	3431	8.1	94	7,309	121	312	3.24
176	4	3333	8.14	94	11,253	135	311	4
179	6	3531	8	93	7,506	123	316	6
207	0.99	3231	6.92	81	2,156	117	366	1.01
196	1.67	3133	7.34	85	3,822	131	345	1.63
203	1.82	3331	7.08	82	4,423	119	358	1.85
206	3.11	3233	6.96	80	5,359	133	364	3.16
210	4	3431	6.83	79	6,930	121	370	4
202	5	3333	7.09	82	10,780	135	357	5
209	7	3531	6.87	80	7,149	123	368	7
209	12	3433	6.86	79	16,734	137	369	12
228	1.09	3231	6.31	73	2,111	117	401	1.10
223	1.91	3133	6.42	74	3,707	131	394	1.75
227	2.03	3331	6.33	74	4,277	119	399	2.06
235	3.55	3233	6.1	70	5,169	133	415	3.60
233	5	3431	6.15	72	6,702	121	411	5
227	8	3531	6.31	73	6,960	123	401	8
251	1.2	3231	5.71	67	2,063	117	443	1.22
254	2.14	3133	5.65	65	3,595	131	448	1.82
261	2.34	3331	5.5	64	4,101	119	460	2.37
258	5	3431	5.57	65	6,494	121	454	5
261	9	3531	5.5	64	6,657	123	460	9
292	0.87	3131	4.92	57	245	115	515	0.89
294	1.41	3231	4.88	57	1,985	117	519	1.43
287	2.25	3133	4.99	58	3,481	131	507	1.90
295	2.65	3331	4.87	57	3,950	119	520	2.60
280	6	3431	5.13	60	6,327	121	493	6
296	10	3531	4.85	56	6,395	123	522	9



Selection tables

Compabloc: Cb / LS, LSES motors / 4 poles

LS, LSES 1500 min <sup>-1</sup> - 50 Hz		Cb - Gearbox					LS, LSES 2600 min <sup>-1</sup> - 87 Hz	
N <sub>S</sub> (min <sup>-1</sup> )	Kp	Cb / MI-MU	i	M (Nm)	F <sub>R</sub> E/2 (N)	Dim. MI < ——— > page	N <sub>S</sub> (min <sup>-1</sup> )	Kp
<b>1.8 kW - 50 Hz</b>		<i>LSES 100 L IFT/IE3</i> <i>LS 90 L FFB2 IFT/NIE - LSES 100 L FFB2 IFT/IE3</i>					<b>3.13 kW - 87 Hz*</b>	
327	0.98	3131	4.38	51	491	115	577	0.99
331	1.59	3231	4.33	50	1,929	117	584	1.61
324	2.32	3133	4.43	51	3,378	131	571	1.95
321	2.88	3331	4.47	52	3,852	119	566	2.67
325	6	3431	4.41	51	6,030	121	573	6
330	11	3531	4.35	51	6,173	123	581	10
365	1.09	3131	3.93	46	682	115	644	1.11
368	1.76	3231	3.89	45	1,875	117	650	1.79
367	2.59	3133	3.91	45	3,270	131	647	2.17
363	3.26	3331	3.95	46	3,708	119	640	2.94
349	7	3431	4.11	48	5,894	121	615	7
370	12	3531	3.88	45	5,945	123	653	11
417	1.25	3131	3.44	40	916	115	736	1.27
419	2.00	3231	3.43	40	1,809	117	738	2.03
387	2.66	3133	3.71	43	3,221	131	682	2.23
407	3.58	3331	3.52	41	3,578	119	718	3.05
399	8	3431	3.6	42	5,648	121	703	8
442	1.32	3131	3.25	38	982	115	778	1.34
465	2.23	3231	3.09	36	1,757	117	820	2.26
454	3.74	3331	3.16	37	3,457	119	801	3.15
451	9	3431	3.18	37	5,427	121	795	9
524	1.57	3131	2.74	32	1,111	115	924	1.57
528	2.53	3231	2.72	32	1,694	117	930	2.56
493	4	3331	2.91	34	3,369	119	870	3.74
506	10	3431	2.83	33	5,227	121	893	10
556	1.66	3131	2.58	30	1,108	115	981	1.56
564	2.7	3231	2.55	30	1,661	117	994	2.74
555	5	3331	2.58	30	3,246	119	979	4
565	11	3431	2.54	30	5,042	121	997	10
628	1.88	3131	2.29	27	1,089	115	1107	1.67
650	3.11	3231	2.21	26	1,594	117	1146	3.00
638	5	3331	2.25	26	3,108	119	1124	4
661	12	3431	2.17	25	4,795	121	1165	12
718	2.07	3131	2	23	1,081	115	1265	1.76
741	3.55	3231	1.94	23	1,532	117	1306	3.25
815	2.19	3131	1.76	21	1,050	115	1438	1.84
923	2.28	3131	1.56	18	1,038	115	1626	1.91
1040	2.36	3131	1.38	16	1,015	115	1834	1.98
985	5	3331	1.46	17	2,701	119	1736	4
1177	2.53	3131	1.22	14	993	115	2076	2.13
1136	5	3331	1.26	15	2,577	119	2003	4
1241	2.61	3131	1.16	13	986	115	2188	2.19

87Hz\* 400VY triangle-coupled motor supplied by drive

LS, LSES 1500 min <sup>-1</sup> - 50 Hz		Cb - Gearbox					LS, LSES 2600 min <sup>-1</sup> - 87 Hz	
N <sub>S</sub> (min <sup>-1</sup> )	Kp	Cb / MI-MU	i	M (Nm)	F <sub>R</sub> E/2 (N)	Dim. MI < ——— > page	N <sub>S</sub> (min <sup>-1</sup> )	Kp
<b>2.2 kW - 50 Hz</b>		<i>LSES 100 LR IFT/IE3</i> <i>LS 100 L FFB2 IFT/NIE - LSES 100 LR FFB2 IFT/IE3</i>					<b>3.83 kW - 87 Hz*</b>	
1.03	0.78	3835	1390	18820	35,995	147		
1.15	0.88	3835	1250	16861	39,173	147		
1.34	1.02	3835	1070	14430	42,517	147		
1.46	1.1	3835	983	13419	43,711	147		
1.73	1.3	3835	829	11320	45,820	147		
1.79	0.88	3735	801	10957	23,298	147		
1.92	1.45	3835	747	10195	46,747	147		
2.10	1.04	3735	684	9347	27,091	147		
2.12	1.6	3835	676	9230	47,427	147		
2.36	1.17	3735	608	8309	29,539	147		
2.30	1.74	3835	623	8504	47,870	147		
2.63	1.3	3735	546	7468	31,522	147		
2.68	2.02	3835	535	7309	48,469	147		
2.98	1.47	3735	481	6574	33,629	147		
2.88	2.17	3835	499	6811	48,671	147		
3.31	1.64	3735	433	5919	35,173	147		
3.28	2.48	3835	437	5964	48,950	147		
3.80	0.83	3635	378	5165	22,720	147		
3.76	1.86	3735	381	5215	36,831	147		
3.72	2.8	3835	386	5271	49,119	147		
4.22	0.92	3635	340	4650	24,167	147		
4.02	1.99	3735	357	4881	37,620	147		
4.17	3.15	3835	344	4694	49,218	147		
4.79	1.05	3635	300	4097	25,721	147		
4.63	2.29	3735	310	4234	39,144	147		
4.66	3.51	3835	308	4205	49,272	147		
5.12	1.12	3635	280	3834	26,461	147		
5.28	2.61	3735	272	3715	40,368	147		
5.44	4	3835	264	3599	49,302	147		
5.55	0.87	3535	251	3532	11,303	147	9.81	0.89
5.70	1.26	3633	252	3506	27,383	141		
5.89	2.98	3733	244	3388	41,139	143		
6.29	0.98	3535	222	3121	13,899	147	11.1	1.01
6.64	1.46	3633	216	3010	28,780	141		
6.62	3.35	3733	217	3015	42,018	143		
7.13	1.10	3533	201	2803	15,906	139	12.6	1.12
7.22	1.59	3633	199	2767	29,463	141		
7.25	3.67	3733	198	2750	42,642	143		
8.30	1.28	3533	173	2406	18,413	139	14.7	1.30
8.29	1.83	3633	173	2411	30,464	141		
8.20	4	3733	175	2431	43,394	143		
9.03	1.39	3533	159	2212	19,638	139	16.0	1.41
9.40	2.07	3633	153	2126	31,265	141		
9.11	5	3733	158	2190	43,962	143		

LS, LSES 1500 min <sup>-1</sup> - 50 Hz		Cb - Gearbox					LS, LSES 2600 min <sup>-1</sup> - 87 Hz	
N <sub>S</sub> (min <sup>-1</sup> )	Kp	Cb / MI-MU	i	M (Nm)	F <sub>R</sub> E/2 (N)	Dim. MI < ——— > page	N <sub>S</sub> (min <sup>-1</sup> )	Kp
<b>2.2 kW - 50 Hz</b>		<i>LSES 100 LR IFT/IE3</i> <i>LS 100 L FFB2 IFT/NIE - LSES 100 LR FFB2 IFT/IE3</i>					<b>3.83 kW - 87 Hz*</b>	
10.2	0.83	3433	140	1956	3,606	137	18.1	0.84
10.4	1.60	3533	138	1927	21,438	139	18.3	1.62
10.5	2.31	3633	137	1908	31,878	141		
10.2	5	3733	141	1953	44,521	143		
11.1	0.90	3433	129	1802	5,761	137	19.6	0.91
11.8	1.81	3533	122	1699	22,878	139	20.8	1.79
11.8	2.59	3633	122	1698	32,467	141		
11.1	6	3733	129	1796	44,891	143		
12.9	1.04	3433	111	1549	9,075	137	22.8	1.06
13.1	2.01	3533	110	1525	23,976	139	23.1	1.94
12.8	2.82	3633	112	1556	32,867	141		
13.9	1.12	3433	104	1443	10,349	137	24.5	1.13
14.7	2.25	3533	97.5	1358	25,031	139	26.0	2.10
14.9	3.25	3633	96.6	1345	33,460	141		
15.8	1.27	3433	90.7	1264	12,345	137	28.0	1.29
16.1	2.45	3533	89.3	1244	25,750	139	28.4	2.23
16.4	3.59	3633	87.3	1216	33,823	141		
17.9	1.44	3433	80.1	1117	13,797	137	31.6	1.45
18.6	2.83	3533	77.2	1075	25,869	139	32.8	2.45
19.3	0.80	3333	74.4	1039	2,244	135	34.1	0.82
20.1	1.61	3433	71.4	995	14,868	137	35.5	1.63
20.6	3.03	3533	69.8	972	25,868	139	36.3	2.59
21.7	0.90	3333	66.1	923	4,421	135	38.4	0.92
22.5	1.79	3433	63.9	891	15,666	137	39.7	1.81
24.9	1.04	3333	57.6	804	6,373	135	44.0	1.05
26.2	2.09	3433	54.7	763	16,510	137	46.3	2.11
27.6	1.15	3333	52.1	727	7,479	135	48.7	1.16
28.5	2.24	3433	50.3	709	16,811	137	50.4	2.26
28.9	4	3533	49.7	699	25,854	139	51.0	4
29.9	6	3633	48.1	676	35,341	141		
31.6	1.31	3333	45.4	634	8,672	135	55.8	1.33
33.8	2.65	3433	42.5	598	17,332	137	59.7	2.67
33.6	5	3533	42.7	600	25,863	139	59.4	5
33.6	7	3633	42.8	602	35,551	141		
36.7	0.83	3233	39.1	545	1,345	133	64.9	0.84
36.5	1.45	3333	39.4	555	9,543	135	64.4	1.48
37.5	2.93	3433	38.2	539	17,554	137	66.3	2.95
36.6	5	3533	39.2	552	25,873	139	64.6	5
36.8	8	3633	39	549	35,699	141		
40.4	0.91	3233	35.5	501	1,961	133	71.4	0.91
42.0	1.67	3333	34.2	482	10,242	135	74.2	1.71
41.5	3.23	3433	34.6	488	17,710	137	73.2	3.25
42.0	6	3533	34.2	481	25,899	139	74.2	6
41.6	9	3633	34.5	485	35,878	141		

87Hz\* 400VY triangle-coupled motor supplied by drive

Selection tables

Compabloc: Cb / LS, LSES motors / 4 poles

LS, LSES 1500 min <sup>-1</sup> - 50 Hz		Cb - Gearbox					LS, LSES 2600 min <sup>-1</sup> - 87 Hz	
N <sub>S</sub> (min <sup>-1</sup> )	K <sub>p</sub>	Cb / MI-MU	i	M (Nm)	F <sub>R</sub> E/2 (N)	Dim. MI < ——— > page	N <sub>S</sub> (min <sup>-1</sup> )	K <sub>p</sub>
<b>2.2 kW - 50 Hz</b>		<i>LSES 100 LR IFT/IE3</i> <i>LS 100 L FFB2 IFT/NIE - LSES 100 LR FFB2 IFT/IE3</i>					<b>3.83 kW - 87 Hz*</b>	
47.4	1.06	3233	30.3	427	3,315	133	83.7	1.04
47.5	1.89	3333	30.2	427	10,703	135	83.8	1.93
45.0	3.5	3433	31.9	449	17,806	137	79.5	3.52
47.6	7	3533	30.1	424	25,929	139	84.1	7
46.2	10	3633	31.1	437	36,013	141		
53.3	1.19	3233	26.9	380	4,319	133	94.1	1.14
51.6	2.05	3333	27.8	392	10,958	135	91.2	2.10
52.3	4	3433	27.4	386	17,925	137	92.5	4
53.1	8	3533	27.1	380	25,959	139	93.7	8
51.8	11	3633	27.7	390	36,146	141		
59.3	1.32	3233	24.2	341	5,155	133	105	1.23
58.4	2.33	3333	24.6	347	11,261	135	103	2.36
56.2	4	3433	25.5	360	17,959	137	99.2	4
59.6	9	3533	24.1	339	25,994	139	105	8
56.3	11	3633	25.5	358	36,234	141		
67.4	1.49	3233	21.3	301	6,027	133	119	1.34
65.6	2.61	3333	21.9	309	11,480	135	116	2.58
64.1	5	3433	22.4	315	17,997	137	113	5
65.8	7	3633	21.8	307	36,380	141	115	9
65.1	9	3533	22.1	310	26,006	139		
74.8	1.64	3233	19.2	271	6,633	133	132	1.44
73.1	2.91	3333	19.6	277	11,642	135	129	2.79
72.6	6	3433	19.8	278	18,007	137	128	6
72.2	10	3633	19.9	280	36,456	141	133	10
75.2	10	3533	19.1	268	24,850	139		
84.4	0.83	3133	17	240	2,569	131		
84.9	1.80	3233	16.9	238	6,610	133	150	1.57
79.4	3.16	3333	18.1	255	11,743	135	140	2.99
81.5	6	3433	17.6	248	18,003	137	144	6
83.2	12	3533	17.2	242	24,075	139	147	11
81.7	12	3633	17.6	247	36,547	141		
89.5	0.88	3133	16	226	2,973	131	158	0.81
90.7	1.89	3233	15.8	223	6,516	133	160	1.64
89.4	3.56	3333	16.1	226	11,859	135	158	3.26
91.0	7	3433	15.8	222	17,989	137	161	7
90.6	13	3633	15.8	223	36,616	141		
101	0.99	3133	14.2	200	3,675	131	178	0.88
105	2.09	3233	13.7	194	6,311	133	185	1.80
103	4	3333	14	197	11,962	135	181	3.63
106	8	3433	13.5	190	17,959	137	188	7
102	17	3633	14.1	199	36,684	141		
115	1.10	3133	12.4	175	4,134	131	204	0.96
119	2.27	3233	12	170	6,123	133	211	1.96
113	5	3333	12.7	178	12,019	135	200	3.97
111	19	3633	13	183	36,728	141		

87Hz\* 400VY triangle-coupled motor supplied by drive

Selection tables

Compabloc: Cb / LS, LSES motors / 4 poles

LS, LSES 1500 min <sup>-1</sup> - 50 Hz		Cb - Gearbox					LS, LSES 2600 min <sup>-1</sup> - 87 Hz	
N <sub>S</sub> (min <sup>-1</sup> )	Kp	Cb / MI-MU	i	M (Nm)	F <sub>R</sub> E/2 (N)	Dim. MI < — > page	N <sub>S</sub> (min <sup>-1</sup> )	Kp
<b>2.2 kW - 50 Hz</b>		<i>LSES 100 LR IFT/IE3</i> <i>LS 100 L FFB2 IFT/NIE - LSES 100 LR FFB2 IFT/IE3</i>					<b>3.83 kW - 87 Hz*</b>	
131	1.21	3133	10.9	154	4,051	131	232	1.05
132	2.44	3233	10.9	153	5,977	133	233	2.10
130	5	3333	11	156	12,079	135	230	4
148	1.32	3133	9.67	136	3,965	131	262	1.14
149	2.63	3233	9.62	136	5,794	133	263	2.27
144	2.91	3333	9.95	140	11,861	135	255	2.98
167	1.42	3133	8.57	121	3,872	131	296	1.23
159	2.75	3233	9.02	127	5,702	133	281	2.38
158	6	3333	9.06	128	11,573	135	280	5
189	1.54	3133	7.57	107	3,775	131	335	1.33
177	2.68	3431	8.1	115	7,248	121	313	2.67
188	3.06	3233	7.63	108	5,456	133	332	2.64
176	3.56	3333	8.14	115	11,160	135	312	3.64
179	5	3531	8	114	7,459	123	317	5
196	1.37	3133	7.34	104	3,686	131	345	1.34
206	2.54	3233	6.96	98	5,253	133	364	2.60
210	3.36	3431	6.83	97	6,876	121	371	3.34
202	4	3333	7.09	100	10,701	135	358	4
209	6	3531	6.87	98	7,107	123	369	5
209	10	3433	6.86	97	16,664	137	370	9.49
223	1.56	3133	6.42	91	3,586	131	395	1.44
227	1.66	3331	6.33	90	4,215	119	400	1.70
235	2.90	3233	6.1	86	5,075	133	415	2.96
233	3.75	3431	6.15	88	6,654	121	412	3.79
224	5	3333	6.41	90	10,380	135	395	5
227	6	3531	6.31	90	6,921	123	402	6
251	0.98	3231	5.71	81	1,985	117	444	1.00
254	1.75	3133	5.65	80	3,488	131	449	1.50
261	1.91	3331	5.5	78	4,046	119	461	1.95
260	3.21	3233	5.51	78	4,936	133	460	3.24
258	4	3431	5.57	79	6,452	121	455	4
257	5	3333	5.59	79	9,945	135	454	5
261	7	3531	5.5	78	6,625	123	461	7
294	1.15	3231	4.88	69	1,916	117	520	1.18
287	1.84	3133	4.99	70	3,396	131	508	1.56
295	2.16	3331	4.87	69	3,902	119	521	2.14
294	3.63	3233	4.88	69	4,773	133	520	3.55
280	4	3431	5.13	73	6,287	121	494	5
296	8	3531	4.85	69	6,363	123	523	8
331	1.30	3231	4.33	62	1,859	117	585	1.32
324	1.90	3133	4.43	62	3,300	131	572	1.61
321	2.35	3331	4.47	64	3,803	119	567	2.20
314	3.87	3233	4.57	65	4,686	133	554	3.74
325	5	3431	4.41	63	5,992	121	575	5
313	6	3333	4.59	65	9,353	135	552	6
330	9	3531	4.35	62	6,146	123	582	8

87Hz\* 400VY triangle-coupled motor supplied by drive

LS, LSES 1500 min <sup>-1</sup> - 50 Hz		Cb - Gearbox					LS, LSES 2600 min <sup>-1</sup> - 87 Hz	
N <sub>S</sub> (min <sup>-1</sup> )	Kp	Cb / MI-MU	i	M (Nm)	F <sub>R</sub> E/2 (N)	Dim. MI < ——— > page	N <sub>S</sub> (min <sup>-1</sup> )	Kp
<b>2.2 kW - 50 Hz</b>		<i>LSES 100 LR IFT/IE3</i> <i>LS 100 L FFB2 IFT/NIE - LSES 100 LR FFB2 IFT/IE3</i>					<b>3.83 kW - 87 Hz*</b>	
365	0.89	3131	3.93	56	23	115	645	0.91
368	1.44	3231	3.89	56	1,810	117	651	1.47
367	2.11	3133	3.91	55	3,198	131	648	1.79
363	2.66	3331	3.95	56	3,666	119	641	2.42
371	5	3233	3.87	55	4,471	133	655	4
349	6	3431	4.11	59	5,858	121	617	6
370	10	3531	3.88	55	5,920	123	654	9
417	1.02	3131	3.44	49	322	115	737	1.04
419	1.64	3231	3.43	49	1,754	117	739	1.67
387	2.17	3133	3.71	52	3,157	131	683	1.84
407	2.92	3331	3.52	50	3,538	119	720	2.51
399	6	3431	3.6	51	5,618	121	704	7
404	11	3531	3.55	50	5,752	123	714	9
442	1.08	3131	3.25	46	455	115	780	1.1
465	1.82	3231	3.09	44	1,707	117	821	1.86
454	3.06	3331	3.16	45	3,422	119	802	2.59
451	7	3431	3.18	45	5,400	121	797	7
468	11	3531	3.07	44	5,489	123	826	10
524	1.28	3131	2.74	39	722	115	926	1.29
528	2.06	3231	2.72	39	1,649	117	932	2.11
493	3.58	3331	2.91	41	3,337	119	871	3.08
506	8	3431	2.83	40	5,202	121	895	8
517	12	3531	2.77	39	5,310	123	914	10
556	1.36	3131	2.58	37	789	115	983	1.29
564	2.2	3231	2.55	36	1,622	117	996	2.26
555	4	3331	2.58	37	3,213	119	981	3.58
565	9	3431	2.54	36	5,020	121	999	9
628	1.53	3131	2.29	33	926	115	1109	1.38
650	2.54	3231	2.21	31	1,560	117	1148	2.47
638	4	3331	2.25	32	3,078	119	1127	3.50
661	10	3431	2.17	31	4,773	121	1167	9
718	1.69	3131	2	29	997	115	1268	1.45
741	2.90	3231	1.94	28	1,497	117	1308	2.67
705	4	3331	2.04	29	2,982	119	1245	3.68
815	1.79	3131	1.76	25	995	115	1440	1.52
820	3.16	3231	1.75	25	1,454	117	1449	2.71
809	4	3331	1.77	25	2,856	119	1429	3.47
923	1.86	3131	1.56	22	982	115	1630	1.58
927	3.43	3231	1.55	22	1,404	117	1637	2.92
1040	1.93	3131	1.38	20	959	115	1838	1.63
989	3.35	3231	1.45	21	1,373	117	1746	2.84
985	4	3331	1.46	21	2,678	119	1740	3.52
1177	2.07	3131	1.22	17	951	115	2080	1.75
1168	3.62	3231	1.23	18	1,303	117	2063	3.07
1136	4	3331	1.26	18	2,559	119	2007	3.70
1241	2.13	3131	1.16	16	944	115	2192	1.81

87Hz\* 400VY triangle-coupled motor supplied by drive

Selection tables

Compabloc: Cb / LS, LSES motors / 4 poles

LS, LSES 1500 min <sup>-1</sup> - 50 Hz		Cb - Gearbox					LS, LSES 2600 min <sup>-1</sup> - 87 Hz	
N <sub>S</sub> (min <sup>-1</sup> )	Kp	Cb / MI-MU	i	M (Nm)	F <sub>R</sub> E/2 (N)	Dim. MI < ——— > page	N <sub>S</sub> (min <sup>-1</sup> )	Kp
<b>3 kW - 50 Hz</b>		<i>LSES 100 LG IFT/IE3</i> <i>LS 100 L FFB3 IFT/NIE - LSES 100 LG FFB3 IFT/IE3</i>					<b>5.22 kW - 87 Hz*</b>	
1.46	0.81	3835	983	18339	36,816	147		
1.73	0.95	3835	829	15471	41,167	147		
1.92	1.06	3835	747	13932	43,119	147		
2.12	1.17	3835	676	12614	44,579	147		
2.36	0.85	3735	608	11350	22,371	147		
2.30	1.27	3835	623	11622	45,548	147		
2.63	0.95	3735	546	10201	25,079	147		
2.68	1.48	3835	535	9988	46,901	147		
2.98	1.08	3735	481	8980	27,957	147		
2.88	1.59	3835	499	9308	47,376	147		
3.31	1.20	3735	433	8085	30,066	147		
3.28	1.81	3835	437	8151	48,064	147		
3.76	1.36	3735	381	7124	32,331	147		
3.72	2.05	3835	386	7204	48,514	147		
4.02	1.45	3735	357	6667	33,409	147		
4.17	2.30	3835	344	6415	48,812	147		
4.63	1.68	3735	310	5784	35,490	147		
4.66	2.57	3835	308	5747	49,009	147		
5.12	0.82	3635	280	5238	22,515	147		
5.28	1.91	3735	272	5075	37,163	147		
5.44	3.00	3835	264	4918	49,184	147		
5.70	0.92	3633	252	4794	23,763	141		
5.89	2.18	3733	244	4633	38,203	143		
6.64	1.07	3633	216	4114	25,673	141		
6.62	2.45	3733	217	4124	39,405	143		
7.13	0.81	3533	201	3832	9,409	139	12.6	0.82
7.22	1.17	3633	199	3782	26,606	141		
7.25	2.68	3733	198	3761	40,259	143		
8.30	0.94	3533	173	3289	12,838	139	14.7	0.95
8.29	1.34	3633	173	3296	27,975	141		
8.20	3.04	3733	175	3325	41,286	143		
9.03	1.02	3533	159	3023	14,517	139	16.0	1.03
9.40	1.52	3633	153	2906	29,071	141		
9.11	3.37	3733	158	2996	42,063	143		
10.4	1.17	3533	138	2634	16,973	139	18.3	1.18
10.5	1.69	3633	137	2608	29,908	141		
10.2	3.78	3733	141	2671	42,828	143		
11.8	1.32	3533	122	2323	18,937	139	20.8	1.30
11.8	1.89	3633	122	2322	30,713	141		
11.1	4	3733	129	2457	43,334	143		
13.1	1.47	3533	110	2085	20,440	139	23.1	1.41
12.8	2.06	3633	112	2127	31,261	141		
13.9	0.82	3433	104	1972	3,369	137	24.5	0.82
14.7	1.65	3533	97.5	1856	21,886	139	26.0	1.53
14.9	2.38	3633	96.6	1839	32,071	141		
15.8	0.93	3433	90.7	1727	6,775	137	28.0	0.94
16.1	1.79	3533	89.3	1700	22,871	139	28.4	1.62
16.4	2.62	3633	87.3	1662	32,568	141		
17.9	1.05	3433	80.1	1527	9,349	137	31.6	1.06
18.6	2.07	3533	77.2	1470	24,324	139	32.8	1.79

87Hz\* 400VY triangle-coupled motor supplied by drive



LS, LSES 1500 min <sup>-1</sup> - 50 Hz		Cb - Gearbox					LS, LSES 2600 min <sup>-1</sup> - 87 Hz	
N <sub>S</sub> (min <sup>-1</sup> )	K <sub>p</sub>	Cb / MI-MU	i	M (Nm)	F <sub>R</sub> E/2 (N)	Dim. MI < ——— > page	N <sub>S</sub> (min <sup>-1</sup> )	K <sub>p</sub>
<b>3 kW - 50 Hz</b>		<i>LSES 100 LG IFT/IE3</i> <i>LS 100 L FFB3 IFT/NIE - LSES 100 LG FFB3 IFT/IE3</i>					<b>5.22 kW - 87 Hz*</b>	
20.1	1.18	3433	71.4	1359	11,311	137	35.5	1.19
20.6	2.21	3533	69.8	1329	25,214	139	36.3	1.88
22.5	1.31	3433	63.9	1218	12,818	137	39.7	1.32
26.2	1.53	3433	54.7	1042	14,467	137	46.3	1.54
27.6	0.84	3333	52.1	994	3,133	135	48.7	0.85
28.5	1.64	3433	50.3	969	15,076	137	50.4	1.65
28.9	3.15	3533	49.7	956	25,867	139	51.0	3.16
29.9	5	3633	48.1	924	34,644	141		
31.6	0.96	3333	45.4	866	5,391	135	55.8	0.97
33.8	1.94	3433	42.5	817	16,171	137	59.7	1.94
33.6	3.66	3533	42.7	821	25,857	139	59.4	3.66
33.6	5	3633	42.8	822	34,930	141		
36.5	1.06	3333	39.4	759	7,043	135	64.4	1.08
37.5	2.15	3433	38.2	736	16,663	137	66.3	2.15
36.6	3.97	3533	39.2	754	25,854	139	64.6	3.97
36.8	6	3633	39	750	35,133	141		
42.0	1.22	3333	34.2	659	8,372	135	74.2	1.25
41.5	2.37	3433	34.6	666	17,027	137	73.2	2.37
42.0	5	3533	34.2	657	25,856	139	74.2	5
41.6	6	3633	34.5	663	35,377	141		
47.5	1.38	3333	30.2	583	9,251	135	83.8	1.41
45.0	2.56	3433	31.9	614	17,266	137	79.5	2.56
47.6	5	3533	30.1	580	25,867	139	84.1	5
46.2	7	3633	31.1	597	35,562	141		
53.3	0.87	3233	26.9	519	1,689	133	94.1	0.83
51.6	1.50	3333	27.8	536	9,740	135	91.2	1.53
52.3	2.97	3433	27.4	528	17,590	137	92.5	2.97
53.1	6	3533	27.1	520	25,883	139	93.7	6
51.8	8	3633	27.7	533	35,744	141		
59.3	0.96	3233	24.2	466	2,555	133	105	0.90
58.4	1.70	3333	24.6	473	10,320	135	103	1.72
56.2	3.18	3433	25.5	492	17,698	137	99.2	3.17
59.6	6	3533	24.1	463	25,907	139	105	6
56.3	8	3633	25.5	490	35,864	141		
67.4	1.09	3233	21.3	411	3,663	133	119	0.98
65.6	1.91	3333	21.9	422	10,741	135	116	1.88
64.1	3.61	3433	22.4	431	17,846	137	113	3.61
65.8	5	3633	21.8	419	36,064	141	115	7
65.1	7	3533	22.1	424	25,689	139		
74.8	1.20	3233	19.2	370	4,540	133	132	1.05
73.1	2.13	3333	19.6	378	11,054	135	129	2.04
72.6	4	3433	19.8	381	17,933	137	128	4.02
72.2	7	3633	19.9	382	36,167	141	133	7.24
75.2	8	3533	19.1	367	24,575	139		
84.9	1.32	3233	16.9	326	5,494	133	150	1.14
79.4	2.31	3333	18.1	348	11,249	135	140	2.18
81.5	5	3433	17.6	339	17,980	137	144	4
83.2	9	3533	17.2	332	23,825	139	147	8
81.7	9	3633	17.6	338	36,292	141		

87Hz\* 400VY triangle-coupled motor supplied by drive

LS, LSES 1500 min <sup>-1</sup> - 50 Hz		Cb - Gearbox					LS, LSES 2600 min <sup>-1</sup> - 87 Hz	
N <sub>S</sub> (min <sup>-1</sup> )	Kp	Cb / MI-MU	i	M (Nm)	F <sub>R</sub> E/2 (N)	Dim. MI < ——— > page	N <sub>S</sub> (min <sup>-1</sup> )	Kp
<b>3 kW - 50 Hz</b>		<i>LSES 100 LG IFT/IE3</i> <i>LS 100 L FFB3 IFT/NIE - LSES 100 LG FFB3 IFT/IE3</i>					<b>5.22 kW - 87 Hz*</b>	
90.7	1.38	3233	15.8	305	5,900	133	160	1.20
89.4	2.60	3333	16.1	309	11,476	135	158	2.38
91.0	5	3433	15.8	304	18,002	137	161	5
90.6	10	3633	15.8	304	36,386	141		
105	1.53	3233	13.7	264	5,950	133	185	1.32
103	2.99	3333	14	269	11,678	135	181	2.65
106	6	3433	13.5	260	18,006	137	188	5.34
102	12	3633	14.1	271	36,479	141		
115	0.81	3133	12.4	240	2,582	131		
119	1.66	3233	12	232	5,803	133	211	1.43
113	3.29	3333	12.7	244	11,790	135	200	2.90
111	14	3633	13	250	36,540	141		
131	0.88	3133	10.9	211	3,399	131		
132	1.78	3233	10.9	210	5,683	133	233	1.53
130	3.59	3333	11	212	11,910	135	230	3.11
148	0.96	3133	9.67	186	3,638	131	262	0.83
149	1.93	3233	9.62	185	5,541	133	263	1.66
144	2.13	3333	9.95	192	11,633	135	255	2.17
167	1.04	3133	8.57	165	3,584	131	296	0.90
159	2.02	3233	9.02	174	5,460	133	281	1.73
158	4	3333	9.06	175	11,385	135	280	3.63
189	1.13	3133	7.57	146	3,520	131	335	0.97
177	1.96	3431	8.1	158	7,122	121	332	1.93
188	2.24	3233	7.63	147	5,255	133	313	1.94
176	2.60	3333	8.14	157	10,976	135	312	2.66
179	3.57	3531	8	155	7,367	123	317	3.53
196	1.00	3133	7.34	141	3,422	131	345	0.98
206	1.86	3233	6.96	134	5,041	133	364	1.90
210	2.46	3431	6.83	133	6,769	121	371	2.43
202	2.99	3333	7.09	137	10,539	135	358	3.05
209	4	3531	6.87	133	7,028	123	369	3.98
209	7	3433	6.86	132	16,529	137	370	7
223	1.14	3133	6.42	124	3,350	131	395	1.05
227	1.22	3331	6.33	123	4,085	119	400	1.24
235	2.12	3233	6.1	118	4,887	133	415	2.16
233	2.74	3431	6.15	120	6,557	121	412	2.77
224	3.31	3333	6.41	124	10,230	135	395	3.37
227	5	3531	6.31	123	6,845	123	402	5
254	1.28	3133	5.65	109	3,281	131	449	1.1
261	1.40	3331	5.5	107	3,929	119	461	1.42
260	2.35	3233	5.51	106	4,771	133	460	2.36
258	3.03	3431	5.57	108	6,363	121	455	3.09
257	3.79	3333	5.59	108	9,818	135	454	3.87
261	5	3531	5.5	107	6,557	123	461	5
294	0.84	3231	4.88	95	1,769	117	520	0.86
287	1.35	3133	4.99	96	3,210	131	508	1.14
295	1.58	3331	4.87	95	3,795	119	521	1.56
294	2.65	3233	4.88	94	4,626	133	520	2.59
280	3.29	3431	5.13	100	6,203	121	494	3.35
296	6	3531	4.85	94	6,304	123	523	6

87Hz\* 400VY triangle-coupled motor supplied by drive

LS, LSES 1500 min <sup>-1</sup> - 50 Hz		Cb - Gearbox					LS, LSES 2600 min <sup>-1</sup> - 87 Hz	
N <sub>S</sub> (min <sup>-1</sup> )	Kp	Cb / MI-MU	i	M (Nm)	F <sub>R</sub> E/2 (N)	Dim. MI < ——— > page	N <sub>S</sub> (min <sup>-1</sup> )	Kp
<b>3 kW - 50 Hz</b>		<i>LSES 100 LG IFT/IE3</i> <i>LS 100 L FFB3 IFT/NIE - LSES 100 LG FFB3 IFT/IE3</i>					<b>5.22 kW - 87 Hz*</b>	
331	0.95	3231	4.33	84	1,733	117	585	0.97
324	1.39	3133	4.43	85	3,135	131	572	1.17
321	1.72	3331	4.47	87	3,707	119	567	1.61
314	2.83	3233	4.57	88	4,551	133	554	2.73
325	3.82	3431	4.41	86	5,918	121	575	3.85
313	5	3333	4.59	88	9,252	135	552	5
330	7	3531	4.35	85	6,089	123	582	6
368	1.05	3231	3.89	76	1,692	117	651	1.08
367	1.55	3133	3.91	75	3,056	131	648	1.31
363	1.95	3331	3.95	77	3,577	119	641	1.76
371	3.34	3233	3.87	75	4,353	133	655	3.01
349	4	3431	4.11	80	5,791	121	617	4
370	7	3531	3.88	75	5,871	123	654	6
419	1.20	3231	3.43	67	1,645	117	739	1.22
387	1.59	3133	3.71	72	3,014	131	683	1.34
407	2.14	3331	3.52	69	3,456	119	720	1.83
399	5	3431	3.6	70	5,555	121	704	5
404	8	3531	3.55	69	5,702	123	714	7
442	0.79	3131	3.25	63	25	115	780	0.81
465	1.33	3231	3.09	60	1,608	117	821	1.36
454	2.24	3331	3.16	62	3,346	119	802	1.89
451	5	3431	3.18	62	5,342	121	797	5
468	8	3531	3.07	60	5,447	123	826	7
524	0.94	3131	2.74	53	50	115	926	0.94
528	1.51	3231	2.72	53	1,559	117	932	1.54
493	2.62	3331	2.91	57	3,264	119	871	2.24
506	6	3431	2.83	55	5,150	121	895	6
517	9	3531	2.77	54	5,268	123	914	8
556	1.00	3131	2.58	50	80	115	983	0.94
564	1.61	3231	2.55	50	1,531	117	996	1.65
555	2.98	3331	2.58	50	3,152	119	981	2.61
565	6	3431	2.54	49	4,973	121	999	6
628	1.12	3131	2.29	45	134	115	1109	1.01
650	1.86	3231	2.21	43	1,478	117	1148	1.80
638	3.02	3331	2.25	44	3,020	119	1127	2.55
661	7	3431	2.17	42	4,730	121	1167	7
718	1.24	3131	2	39	395	115	1268	1.06
741	2.12	3231	1.94	38	1,426	117	1308	1.95
705	3.18	3331	2.04	40	2,927	119	1245	2.68
815	1.31	3131	1.76	34	601	115	1440	1.11
820	2.31	3231	1.75	34	1,389	117	1449	1.98
809	3.00	3331	1.77	35	2,803	119	1429	2.53
923	1.36	3131	1.56	30	750	115	1630	1.15
927	2.51	3231	1.55	30	1,342	117	1637	2.13
1040	1.41	3131	1.38	27	841	115	1838	1.19
989	2.45	3231	1.45	28	1,319	117	1746	2.07
985	3.04	3331	1.46	28	2,639	119	1740	2.57
1177	1.51	3131	1.22	24	854	115	2080	1.28
1168	2.65	3231	1.23	24	1,253	117	2063	2.24
1136	3.20	3331	1.26	25	2,516	119	2007	2.70
1241	1.56	3131	1.16	23	847	115	2192	1.32

87Hz\* 400VY triangle-coupled motor supplied by drive

Selection tables

Compabloc: Cb / LS, LSES motors / 4 poles

LS, LSES 1500 min <sup>-1</sup> - 50 Hz		Cb - Gearbox					LS, LSES 2600 min <sup>-1</sup> - 87 Hz	
N <sub>S</sub> (min <sup>-1</sup> )	K <sub>p</sub>	Cb / MI-MU	i	M (Nm)	F <sub>R</sub> E/2 (N)	Dim. MI < ——— > page	N <sub>S</sub> (min <sup>-1</sup> )	K <sub>p</sub>
<b>4 kW - 50 Hz</b>		LSES 112 MU IFT/IE3 LS 112 MG FFB3 IFT/NIE - LSES 112 MU FFB3 IFT/IE3					<b>6.96 kW - 87 Hz*</b>	
1.91	0.79	3835	747	18670	36,253	147		
2.11	0.87	3835	676	16903	39,110	147		
2.30	0.95	3835	623	15574	41,027	147		
2.67	1.10	3835	535	13385	43,749	147		
2.97	0.81	3735	481	12030	20,768	147		
2.87	1.18	3835	499	12473	44,723	147		
3.30	0.89	3735	433	10831	23,593	147		
3.27	1.35	3835	437	10922	46,165	147		
3.75	1.02	3735	381	9544	26,628	147		
3.70	1.53	3835	386	9653	47,142	147		
4.01	1.09	3735	357	8931	28,072	147		
4.16	1.72	3835	344	8596	47,817	147		
4.62	1.25	3735	310	7749	30,860	147		
4.64	1.92	3835	308	7701	48,290	147		
5.26	1.43	3735	272	6798	33,100	147		
5.42	2.24	3835	264	6591	48,751	147		
5.87	1.63	3733	244	6212	34,481	143		
5.99	2.47	3835	239	5970	48,949	147		
6.61	0.80	3633	216	5515	21,735	141		
6.59	1.83	3733	217	5529	36,093	143		
7.19	0.87	3633	199	5070	22,986	141		
7.23	2.00	3733	198	5043	37,238	143		
6.79	2.81	3835	211	5265	49,120	147		
8.26	1.00	3633	173	4417	24,821	141		
8.18	2.27	3733	175	4458	38,616	143		
9.36	1.13	3633	153	3895	26,289	141		
9.07	2.51	3733	158	4017	39,657	143		
10.3	0.87	3533	138	3531	11,309	139	18.3	0.87
10.4	1.26	3633	137	3496	27,412	141		
10.2	2.82	3733	141	3581	40,683	143		
11.7	0.99	3533	122	3114	13,943	139	20.8	0.97
11.7	1.41	3633	122	3112	28,491	141		
11.1	3.06	3733	129	3294	41,361	143		
13.1	1.10	3533	110	2795	15,957	139	23.1	1.05
12.8	1.54	3633	112	2851	29,225	141		
12.9	3.56	3733	111	2825	42,465	143		
14.7	1.23	3533	97.5	2488	17,895	139	26.0	1.13
14.8	1.77	3633	96.6	2465	30,311	141		
14.1	3.87	3733	102	2591	43,017	143		
16.0	1.34	3533	89.3	2279	19,215	139	28.4	1.20
16.4	1.96	3633	87.3	2228	30,977	141		
15.9	4	3733	89.9	2292	43,723	143		
17.9	0.79	3433	80.1	2046	2,309	137	31.6	0.79
18.5	1.54	3533	77.2	1970	21,166	139	32.8	1.33
18.6	2.22	3633	76.9	1961	31,729	141		
18.6	5	3733	76.8	1957	44,512	143		

87Hz\* 400VY triangle-coupled motor supplied by drive

LS, LSES 1500 min <sup>-1</sup> - 50 Hz		Cb - Gearbox					LS, LSES 2600 min <sup>-1</sup> - 87 Hz	
N <sub>S</sub> (min <sup>-1</sup> )	Kp	Cb / MI-MU	i	M (Nm)	F <sub>R</sub> E/2 (N)	Dim. MI < ——— > page	N <sub>S</sub> (min <sup>-1</sup> )	Kp
<b>4 kW - 50 Hz</b>		<i>LSES 112 MU IFT/IE3 LS 112 MG FFB3 IFT/NIE - LSES 112 MU FFB3 IFT/IE3</i>					<b>6.96 kW - 87 Hz*</b>	
20.0	0.88	3433	71.4	1822	5,494	137	35.5	0.88
20.5	1.65	3533	69.8	1781	22,360	139	36.3	1.40
20.2	2.40	3633	70.8	1807	32,161	141		
20.9	5	3733	68.3	1740	45,022	143		
22.4	0.98	3433	63.9	1632	8,023	137	39.7	0.98
23.3	1.80	3533	61.4	1567	23,711	139	41.3	1.51
22.7	2.70	3633	63	1606	32,725	141		
26.1	1.14	3433	54.7	1397	10,889	137	46.3	1.14
25.3	1.89	3533	56.6	1444	24,488	139	44.8	1.58
25.4	3.01	3633	56.2	1434	33,209	141		
28.9	1.26	3433	49.6	1265	12,332	137	51.2	1.25
28.8	2.35	3533	49.7	1281	25,517	139	51.0	2.34
29.8	3.37	3633	48.1	1239	33,759	141		
29.8	5.05	3733	48	1237	46,209	143		
32.7	1.42	3433	43.7	1116	13,809	137	58.0	1.42
33.5	2.73	3533	42.7	1100	25,867	139	59.4	2.72
33.4	3.70	3633	42.8	1102	34,142	141		
33.3	6	3733	43	1107	46,514	143		
34.8	0.79	3333	41.1	1050	2,030	135	61.7	0.79
37.4	1.60	3433	38.2	986	14,935	137	66.3	1.60
36.5	2.96	3533	39.2	1011	25,869	139	64.6	2.95
36.7	4	3633	39	1006	34,415	141		
35.6	7	3733	40.2	1035	46,686	143		
38.4	0.87	3333	37.3	953	3,891	135	68.0	0.87
41.3	1.77	3433	34.6	893	15,652	137	73.2	1.76
41.8	3.38	3533	34.2	881	25,862	139	74.2	3.36
41.5	5	3633	34.5	889	34,742	141		
39.8	9	3733	36	926	46,941	143		
47.3	1.03	3333	30.2	781	6,719	135	83.8	1.05
44.8	1.91	3433	31.9	823	16,136	137	79.5	1.90
47.5	3.82	3533	30.1	777	25,800	139	84.1	3.79
46.0	5	3633	31.1	801	34,990	141		
44.9	11	3733	31.8	821	47,191	143		
51.4	1.12	3333	27.8	718	7,609	135	91.2	1.14
52.2	2.21	3433	27.4	707	16,821	137	92.5	2.20
52.9	4	3533	27.1	697	25,854	139	93.7	4
51.6	6	3633	27.7	714	35,234	141		
50.3	12	3733	28.4	732	47,400	143		
58.2	1.27	3333	24.6	634	8,670	135	103	1.28
56.0	2.37	3433	25.5	659	17,063	137	99.2	2.35
59.4	5	3533	24.1	621	25,860	139	105	5
56.1	6	3633	25.5	657	35,395	141		
56.8	13	3733	25.2	649	47,595	143		
67.1	0.81	3233	21.3	550	1,291	133		
65.3	1.43	3333	21.9	565	9,441	135	116	1.40
63.9	2.70	3433	22.4	577	17,415	137	113	2.67
64.8	5	3533	22.1	569	25,317	139	115	5
65.4	7	3633	21.9	563	35,658	141		
63.4	15	3733	22.6	581	47,754	143		

87Hz\* 400VY triangle-coupled motor supplied by drive

LS, LSES 1500 min <sup>-1</sup> - 50 Hz		Cb - Gearbox					LS, LSES 2600 min <sup>-1</sup> - 87 Hz	
N <sub>S</sub> (min <sup>-1</sup> )	K <sub>p</sub>	Cb / MI-MU	i	M (Nm)	F <sub>R</sub> E/2 (N)	Dim. MI < ——— > page	N <sub>S</sub> (min <sup>-1</sup> )	K <sub>p</sub>
<b>4 kW - 50 Hz</b>		<i>LSES 112 MU IFT/IE3</i> <i>LS 112 MG FFB3 IFT/NIE - LSES 112 MU FFB3 IFT/IE3</i>					<b>6.96 kW - 87 Hz*</b>	
74.5	0.90	3233	19.2	495	2 053	133		
72.8	1.59	3333	19.6	507	10 017	135	129	1.51
72.3	3.04	3433	19.8	510	17 645	137	128	2.98
75.0	6	3533	19.1	492	24 257	139	133	5
71.3	8	3633	20	517	35 789	141		
71.1	16	3733	20.1	518	47 903	143		
84.6	0.99	3233	16.9	436	3 134	133	150	0.85
79.1	1.73	3333	18.1	467	10 377	135	140	1.62
81.2	3.4	3433	17.6	454	17 795	137	144	3.26
83.0	7	3533	17.2	444	23 540	139	147	6
80.7	9	3633	17.7	457	35 957	141		
80	18	3733	17.8	459	48 042	143		
90	1.03	3233	15.8	408	3 710	133	160	0.89
89	1.94	3333	16.1	414	10 796	135	158	1.76
91	3.78	3433	15.8	407	17 891	137	161	3.56
94	7	3533	15.2	391	22 656	139	167	6
94	10	3633	15.1	390	36 145	141		
91	20	3733	15.7	404	48 172	143		
104	1.14	3233	13.7	354	4 876	133	185	0.98
102	2.23	3333	14	361	11 170	135	181	1.96
106	4	3433	13.5	348	17 971	137	188	3.96
102	8	3533	14	360	22 105	139	181	7
106	11	3633	13.5	347	36 266	141		
104	23	3733	13.8	356	48 286	143		
120	1.25	3233	12	308	5 890	133	211	1.08
113	2.46	3333	12.7	327	11 380	135	200	2.15
117	5	3433	12.2	315	17 996	137	207	4
115	8	3533	12.4	320	21 326	139	204	7
110	10	3633	13	335	36 301	141		
133	1.34	3233	10.9	278	5 804	133	233	1.16
130	2.69	3333	11	285	11 605	135	230	2.31
133	5	3433	10.8	278	18 007	137	235	5
129	9	3533	11.1	286	20 598	139	228	8
128	11	3633	11.1	287	36 435	141		
149	1.44	3233	9.62	248	5 224	133	263	1.23
143	2.94	3333	9.98	258	11 464	135	254	2.52
148	6	3433	9.67	249	18 003	137	262	5
140	12	3633	10.2	263	36 502	141		
148	31	3733	9.64	248	48 539	143		
159	1.51	3233	9.02	233	5 163	133	281	1.29
158	3.15	3333	9.06	234	11 162	135	280	2.69
166	6	3433	8.6	222	17 644	137	295	5
158	13	3633	9.03	233	36 587	141		
166	34	3733	8.62	222	48 601	143		
187	1.67	3233	7.63	197	5 004	133	332	1.43
179	2.67	3531	8	208	7 258	123	317	2.62
182	3.45	3333	7.9	203	10 723	135	323	2.95
186	6	3433	7.69	198	17 050	137	329	6
185	16	3633	7.71	199	36 683	141		
186	38	3733	7.68	198	48 659	143		

87Hz\* 400VY triangle-coupled motor supplied by drive

LS, LSES 1500 min <sup>-1</sup> - 50 Hz		Cb - Gearbox					LS, LSES 2600 min <sup>-1</sup> - 87 Hz	
N <sub>S</sub> (min <sup>-1</sup> )	K <sub>p</sub>	Cb / MI-MU	i	M (Nm)	F <sub>R</sub> E/2 (N)	Dim. MI < ——— > page	N <sub>S</sub> (min <sup>-1</sup> )	K <sub>p</sub>
<b>4 kW - 50 Hz</b>		<i>LSES 112 MU IFT/IE3 LS 112 MG FFB3 IFT/NIE - LSES 112 MU FFB3 IFT/IE3</i>					<b>6.96 kW - 87 Hz*</b>	
206	1.39	3233	6.96	180	4,777	133	364	1.41
202	2.23	3333	7.09	183	10,350	135	358	2.26
208	3.02	3531	6.87	179	6,932	123	369	2.95
208	5	3433	6.86	177	16,376	137	370	5
199	8	3533	7.18	185	17,939	139	353	7
208	17	3633	6.86	177	36,745	141		
207	41	3733	6.9	178	48,705	143		
234	1.58	3233	6.1	158	4,658	133	415	1.60
232	2.05	3431	6.15	160	6,444	121	412	2.05
223	2.47	3333	6.41	166	10,059	135	395	2.50
227	3.41	3531	6.31	164	6,759	123	402	3.35
230	6	3433	6.21	160	15,888	137	408	5
224	8	3533	6.38	164	17,290	139	397	8
230	30	3733	6.21	160	48,748	143		
259	1.75	3233	5.51	142	4,566	133	460	1.75
257	2.26	3431	5.57	145	6,258	121	455	2.29
256	2.83	3333	5.59	144	9,672	135	454	2.87
260	3.91	3531	5.5	143	6,480	123	461	3.84
261	6	3433	5.48	141	15,284	137	463	5
251	9	3533	5.7	147	16,683	139	445	9
254	33	3733	5.63	145	48,783	143		
294	1.18	3331	4.87	127	3,484	119	521	1.16
293	1.98	3233	4.88	126	4,444	133	520	1.92
279	2.45	3431	5.13	134	6,106	121	494	2.48
283	3.13	3333	5.06	131	9,393	135	501	3.17
295	4	3531	4.85	126	6,234	123	523	4
291	7	3433	4.91	127	14,770	137	516	6
291	37	3733	4.91	127	48,826	143		
320	1.29	3331	4.47	117	3,473	119	567	1.19
313	2.11	3233	4.57	118	4,380	133	554	2.02
324	2.85	3431	4.41	115	5,834	121	575	2.86
312	3.45	3333	4.59	119	9,127	135	552	3.49
329	5	3531	4.35	113	6,029	123	582	5
327	6	3433	4.37	113	14,244	137	580	6
326	41	3733	4.39	113	48,858	143		
367	0.79	3231	3.89	102	1,542	117	651	0.80
362	1.45	3331	3.95	103	3,458	119	641	1.31
370	2.50	3233	3.87	100	4,212	133	655	2.23
348	3.06	3431	4.11	107	5,711	121	617	3.10
359	3.98	3333	3.98	103	8,749	135	637	4
369	5	3531	3.88	101	5,812	123	654	5
366	6	3433	3.91	101	13,753	137	648	6
366	46	3733	3.91	101	48,887	143		
417	0.89	3231	3.43	89	1,514	117	739	0.91
406	1.60	3331	3.52	92	3,361	119	720	1.36
397	3.50	3431	3.6	94	5,482	121	704	3.54
403	6	3531	3.55	92	5,648	123	714	5
406	51	3733	3.52	91	48,911	143		



LS, LSES 1500 min <sup>-1</sup> - 50 Hz		Cb - Gearbox					LS, LSES 2600 min <sup>-1</sup> - 87 Hz	
N <sub>S</sub> (min <sup>-1</sup> )	K <sub>p</sub>	Cb / MI-MU	i	M (Nm)	F <sub>R</sub> E/2 (N)	Dim. MI < ——— > page	N <sub>S</sub> (min <sup>-1</sup> )	K <sub>p</sub>
<b>4 kW - 50 Hz</b>		<i>LSES 112 MU IFT/IE3</i> <i>LS 112 MG FFB3 IFT/NIE - LSES 112 MU FFB3 IFT/IE3</i>					<b>6.96 kW - 87 Hz*</b>	
463	0.99	3231	3.09	81	1,480	117	821	1.01
453	1.67	3331	3.16	82	3,262	119	802	1.40
449	3.96	3431	3.18	83	5,277	121	797	3.93
466	6	3531	3.07	80	5,401	123	826	5
464	58	3733	3.08	79	48,938	143		
526	1.13	3231	2.72	71	1,445	117	932	1.14
492	1.95	3331	2.91	76	3,182	119	871	1.67
505	4	3431	2.83	74	5,089	121	895	4
515	7	3531	2.77	72	5,224	123	914	6
562	1.2	3231	2.55	66	1,428	117	996	1.22
554	2.23	3331	2.58	67	3,076	119	981	1.94
563	5	3431	2.54	66	4,918	121	999	5
586	7	3531	2.44	64	5,020	123	1038	6
648	1.39	3231	2.21	58	1,378	117	1148	1.34
636	2.26	3331	2.25	59	2,950	119	1127	1.89
658	5	3431	2.17	57	4,680	121	1167	5
636	7	3531	2.25	59	4,891	123	1127	6
738	1.58	3231	1.94	51	1,335	117	1308	1.45
702	2.37	3331	2.04	53	2,865	119	1245	1.99
727	6	3431	1.97	51	4,537	121	1288	5
715	8	3531	2	52	4,710	123	1268	6
817	1.73	3231	1.75	46	1,302	117	1449	1.47
806	2.24	3331	1.77	46	2,749	119	1429	1.88
824	6	3431	1.74	45	4,359	121	1461	5
801	8	3531	1.79	47	4,539	123	1420	7
924	1.87	3231	1.55	40	1,266	117	1637	1.58
890	2.24	3331	1.61	42	2,663	119	1578	1.88
919	7	3431	1.56	41	4,205	121	1630	6.28
985	1.83	3231	1.45	38	1,241	117	1746	1.54
981	2.27	3331	1.46	38	2,585	119	1740	1.91
1033	6	3431	1.38	36	4,052	121	1831	6
1164	1.98	3231	1.23	32	1,186	117	2063	1.66
1132	2.39	3331	1.26	33	2,471	119	2007	2.00
1155	6	3431	1.24	32	3,909	121	2048	6

LS, LSES 1500 min <sup>-1</sup> - 50 Hz		Cb - Gearbox					LS, LSES 2600 min <sup>-1</sup> - 87 Hz	
N <sub>S</sub> (min <sup>-1</sup> )	Kp	Cb / MI-MU	i	M (Nm)	F <sub>R</sub> E/2 (N)	Dim. MI < ——— > page	N <sub>S</sub> (min <sup>-1</sup> )	Kp
<b>5.5 kW - 50 Hz</b>		<i>LSES 132 SM IFT/IE3</i> <i>LS 132 S FFB3 IFT/NIE - LSES 132 SM FFB4 IFT/IE3</i>					<b>9.57 kW - 87 Hz*</b>	
2.71	0.81	3835	535	18172	37,094	147		
2.91	0.87	3835	499	16933	39,064	147		
3.32	1.00	3835	437	14828	42,015	147		
3.75	1.13	3835	386	13106	44,057	147		
4.06	0.80	3735	357	12123	20,550	147		
4.22	1.27	3835	344	11670	45,503	147		
4.68	0.92	3735	310	10517	24,334	147		
4.71	1.41	3835	308	10456	46,545	147		
5.34	1.05	3735	272	9227	27,374	147		
5.50	1.65	3835	264	8948	47,606	147		
5.95	1.20	3733	244	8437	29,237	143		
6.07	1.82	3835	239	8105	48,088	147		
6.69	1.34	3733	217	7509	31,425	143		
7.33	1.47	3733	198	6849	32,980	143		
6.88	2.07	3835	211	7148	48,538	147		
8.29	1.67	3733	175	6055	34,852	143		
9.50	0.83	3633	153	5289	22,369	141		
9.20	1.85	3733	158	5455	36,266	143		
10.6	0.93	3633	137	4747	23,893	141		
10.3	2.08	3733	141	4864	37,659	143		
11.9	1.04	3633	122	4226	25,359	141		
11.2	2.25	3733	129	4473	38,581	143		
13.2	0.81	3533	110	3795	9,642	139		
13.0	1.13	3633	112	3872	26,356	141		
13.1	2.62	3733	111	3837	40,079	143		
14.9	0.90	3533	97.5	3378	12,276	139	25.9	0.83
15.0	1.31	3633	96.6	3347	27,831	141		
14.3	2.85	3733	102	3519	40,829	143		
16.2	0.99	3533	89.3	3095	14,063	139	28.3	0.87
16.6	1.44	3633	87.3	3026	28,735	141		
16.1	3.21	3733	89.9	3113	41,788	143		
18.8	1.14	3533	77.2	2675	16,714	139	32.8	0.96
18.9	1.63	3633	76.9	2662	29,756	141		
18.9	3.71	3733	76.8	2658	42,860	143		
20.8	1.21	3533	69.8	2418	18,337	139	36.2	1.02
20.5	1.77	3633	70.8	2454	30,342	141		
21.2	4.00	3733	68.3	2364	43,553	143		
23.6	1.32	3533	61.4	2128	20,168	139	41.2	1.10
23.0	1.98	3633	63	2181	31,109	141		
26.5	0.84	3433	54.7	1896	4,454	137	46.2	0.83
25.6	1.38	3533	56.6	1961	21,223	139	44.7	1.15
25.8	2.22	3633	56.2	1948	31,766	141		
29.3	0.93	3433	49.6	1717	6,904	137	51.1	0.91
29.2	1.73	3533	49.7	1740	22,619	139	50.9	1.70
30.2	2.48	3633	48.1	1682	32,513	141		
30.2	3.71	3733	48	1680	45,164	143		
33.2	1.05	3433	43.7	1515	9,495	137	57.9	1.03
34.0	2.01	3533	42.7	1493	24,178	139	59.3	1.97
33.9	2.72	3633	42.8	1497	33,033	141		
33.7	4	3733	43	1504	45,580	143		

87Hz\* 400VY triangle-coupled motor supplied by drive

LS, LSES 1500 min <sup>-1</sup> - 50 Hz		Cb - Gearbox					LS, LSES 2600 min <sup>-1</sup> - 87 Hz	
N <sub>S</sub> (min <sup>-1</sup> )	Kp	Cb / MI-MU	i	M (Nm)	F <sub>R</sub> E/2 (N)	Dim. MI < — > page	N <sub>S</sub> (min <sup>-1</sup> )	Kp
<b>5.5 kW - 50 Hz</b>		<i>LSES 132 SM IFT/IE3</i> <i>LS 132 S FFB3 IFT/NIE - LSES 132 SM FFB4 IFT/IE3</i>					<b>9.57 kW - 87 Hz*</b>	
37.9	1.18	3433	38.2	1339	11 534	137	66.2	1.16
37.0	2.18	3533	39.2	1373	24 936	139	64.5	2.14
37.2	3.13	3633	39	1365	33 403	141		
36.1	5	3733	40.2	1405	45 813	143		
41.9	1.30	3433	34.6	1212	12 872	137	73.1	1.28
42.4	2.49	3533	34.2	1196	25 854	139	74.0	2.44
42.0	3.50	3633	34.5	1207	33 848	141		
40.3	6	3733	36	1258	46 159	143		
45.5	1.41	3433	31.9	1117	13 796	137	79.3	1.38
48.1	2.81	3533	30.1	1055	25 869	139	83.9	2.76
46.7	3.84	3633	31.1	1087	34 184	141		
45.5	8	3733	31.8	1114	46 498	143		
52.2	0.83	3333	27.8	974	3 496	135	91.0	0.83
52.9	1.63	3433	27.4	960	15 146	137	92.3	1.60
53.6	3.12	3533	27.1	947	25 866	139	93.5	3.04
52.3	4	3633	27.7	970	34 515	141		
51.0	9	3733	28.4	994	46 782	143		
59.0	0.94	3333	24.6	861	5 477	135	103	0.93
56.8	1.75	3433	25.5	895	15 641	137	99.0	1.71
60.2	3.50	3533	24.1	843	25 220	139	105	3.34
56.9	5	3633	25.5	892	34 735	141		
57.6	10	3733	25.2	881	47 048	143		
66.3	1.05	3333	21.9	767	6 922	135	116	1.02
64.8	1.99	3433	22.4	783	16 385	137	113	1.94
65.7	3.80	3533	22.1	772	24 627	139	115	3.58
66.3	5	3633	21.9	765	35 091	141		
64.3	11	3733	22.6	790	47 263	143		
73.8	1.17	3333	19.6	688	8 001	135	129	1.10
73.3	2.24	3433	19.8	692	16 898	137	128	2.17
76.0	4	3533	19.1	667	23 650	139	133	3.90
72.3	6	3633	20	702	35 269	141		
72.1	12	3733	20.1	704	47 465	143		
80.2	1.27	3333	18.1	634	8 677	135	140	1.18
82.4	2.50	3433	17.6	617	17 255	137	144	2.37
84.1	5	3533	17.2	603	22 985	139	147	4
81.8	6	3633	17.7	621	35 497	141		
81.3	13	3733	17.8	624	47 654	143		
90.3	1.43	3333	16.1	563	9 467	135	158	1.28
91.9	2.78	3433	15.8	552	17 506	137	160	2.59
95.6	5	3533	15.2	531	22 156	139	167	5
95.8	7	3633	15.1	530	35 752	141		
92.5	15	3733	15.7	549	47 831	143		
106	0.84	3233	13.7	481	2 296	133		
104	1.64	3333	14	490	10 173	135	181	1.43
107	3.23	3433	13.5	473	17 749	137	187	2.88
104	6	3533	14	489	21 639	139	181	5
108	8	3633	13.5	471	35 917	141		
105	17	3733	13.8	483	47 986	143		
121	0.91	3233 MI	12	420	2 369	133		
115	1.81	3333	12.7	443	10 571	135	200	1.56
119	3.55	3433	12.2	428	17 851	137	207	3.07
117	6	3533	12.4	435	20 904	139	204	5
112	8	3633	13	454	35 964	141		

87Hz\* 400VY triangle-coupled motor supplied by drive

LS, LSES 1500 min <sup>-1</sup> - 50 Hz		Cb - Gearbox					LS, LSES 2600 min <sup>-1</sup> - 87 Hz	
N <sub>S</sub> (min <sup>-1</sup> )	K <sub>p</sub>	Cb / MI-MU	i	M (Nm)	F <sub>R</sub> E/2 (N)	Dim. MI <—> page	N <sub>S</sub> (min <sup>-1</sup> )	K <sub>p</sub>
<b>5.5 kW - 50 Hz</b>		<i>LSES 132 SM IFT/IE3</i> <i>LS 132 S FFB3 IFT/NIE - LSES 132 SM FFB4 IFT/IE3</i>					<b>9.57 kW - 87 Hz*</b>	
134	0,98	3233 MI	10,9	380	2 458	133	232	0,83
132	1,97	3333	11	386	11 000	135	229	1,68
134	3,91	3433	10,8	378	17 937	137	235	3,34
131	7	3533	11,1	388	20 215	139	228	6
130	8	3633	11,1	390	36 146	141		
151	1,06	3233 MI	9,62	337	4 734	133	263	0,89
145	2,16	3333	9,98	350	11 037	135	253	1,83
150	4	3433	9,67	339	17 886	137	262	3,59
142	9	3633	10,2	358	36 237	141		
150	23	3733	9,64	337	48 329	143		
161	1,11	3233 MI	9,02	316	4 705	133	280	0,94
160	2,31	3333	9,06	317	10 772	135	279	1,96
169	5	3433	8,6	301	17 290	137	294	3,87
161	10	3633	9,03	316	36 353	141		
168	25	3733	8,62	302	48 414	143		
190	1,23	3233 MI	7,63	268	4 610	133	331	1,04
181	1,96	3531	8	283	7 055	123	316	1,90
185	2,53	3333	7,85	275	10 380	135	322	2,15
188	4	3433	7,69	269	16 729	137	329	4
188	12	3633	7,71	270	36 483	141		
189	28	3733	7,68	269	48 492	143		
208	1,02	3233 MI	6,96	244	4 374	133	364	1,02
205	1,64	3333	7,09	248	10 013	135	357	1,64
211	2,22	3531	6,87	243	6 753	123	368	2,15
211	3,90	3433	6,86	240	16 055	137	369	3,73
202	6	3533	7,18	251	17 653	139	352	5
211	12	3633	6,86	240	36 567	141		
210	30	3733	6,9	242	48 555	143		
238	1,17	3233 MI	6,1	214	4 302	133	415	1,17
236	1,51	3431	6,15	218	6 237	121	411	1,49
226	1,82	3333	6,41	225	9 750	135	395	1,82
230	2,51	3531	6,31	223	6 591	123	401	2,44
233	4	3433	6,21	218	15 588	137	407	3,98
227	6	3533	6,38	223	17 029	139	396	6
234	22	3733	6,21	217	48 613	143		
263	1,29	3233 MI	5,51	193	4 240	133	459	1,27
260	1,66	3431	5,57	197	6 067	121	454	1,66
259	2,09	3333	5,59	196	9 396	135	453	2,09
264	2,88	3531	5,5	194	6 329	123	460	2,79
265	4	3433	5,48	192	15 014	137	462	3,88
255	7	3533	5,7	199	16 445	139	444	6
258	24	3733	5,6	197	48 660	143		
298	0,87	3331	4,87	172	2 643	119	520	0,84
297	1,46	3233 MI	4,88	171	4 155	133	519	1,40
282	1,81	3431	5,13	182	5 927	121	493	1,81
287	2,30	3333	5,06	177	9 145	135	500	2,30
299	3,25	3531	4,85	171	6 097	123	522	3,05
295	5	3433	4,91	172	14 527	137	515	5
295	27	3733	4,91	172	48 720	143		

LS, LSES 1500 min <sup>-1</sup> - 50 Hz		Cb - Gearbox					LS, LSES 2600 min <sup>-1</sup> - 87 Hz	
N <sub>S</sub> (min <sup>-1</sup> )	Kp	Cb / MI-MU	i	M (Nm)	F <sub>R</sub> E/2 (N)	Dim. MI < ——— > page	N <sub>S</sub> (min <sup>-1</sup> )	Kp
<b>5.5 kW - 50 Hz</b>		<i>LSES 132 SM IFT/IE3</i> <i>LS 132 S FFB3 IFT/NIE - LSES 132 SM FFB4 IFT/IE3</i>					<b>9.57 kW - 87 Hz*</b>	
324	0,95	3331	4,47	158	2 695	119	566	0,87
317	1,56	3233 MI	4,57	160	4 110	133	553	1,47
329	2,10	3431	4,41	156	5 675	121	573	2,08
316	2,54	3333	4,59	161	8 898	135	551	2,54
333	3,64	3531	4,35	154	5 900	123	581	3,27
332	5	3433	4,37	153	14 023	137	579	5
330	30	3733	4,39	154	48 763	143		
367	1,07	3331	3,95	140	2 737	119	640	0,95
375	1,84	3233 MI	3,87	136	3 978	133	654	1,62
353	2,26	3431	4,11	145	5 559	121	615	2,25
364	2,93	3333	3,98	139	8 548	135	636	2,93
374	3,93	3531	3,88	137	5 694	123	653	3,47
371	4	3433	3,91	137	13 549	137	647	4
371	34	3733	3,91	137	48 802	143		
412	1,18	3331	3,52	125	2 759	119	718	0,99
403	2,58	3431	3,6	127	5 345	121	703	2,57
408	4	3531	3,55	126	5 531	123	713	3,62
412	38	3733	3,52	123	48 835	143		
459	1,23	3331	3,16	112	2 770	119	801	1,02
456	2,91	3431	3,18	113	5 149	121	795	2,86
472	4	3531	3,07	109	5 298	123	824	3,92
470	42	3733	3,08	108	48 870	143		
533	0,83	3231 MI	2,72	96	1 125	117	930	0,83
498	1,44	3331	2,91	103	2 771	119	870	1,21
512	3,24	3431	2,83	100	4 973	121	893	3,11
523	5	3531	2,77	98	5 126	123	912	4
570	0,89	3231 MI	2,55	90	1 162	117	994	0,89
561	1,64	3331	2,58	91	2 766	119	979	1,41
571	3,51	3431	2,54	90	4 807	121	997	3,36
594	5	3531	2,44	86	4 935	123	1036	4
657	1,02	3231 MI	2,21	78	1 232	117	1146	0,97
644	1,65	3331	2,25	80	2 715	119	1124	1,38
667	3,90	3431	2,17	77	4 581	121	1165	3,73
644	5	3531	2,25	80	4 807	123	1124	4
748	1,17	3231 MI	1,94	69	1 199	117	1306	1,05
712	1,74	3331	2,04	72	2 693	119	1243	1,45
737	4	3431	1,97	70	4 441	121	1286	3,98
725	6	3531	2	71	4 631	123	1265	5
829	1,27	3231 MI	1,75	62	1 176	117	1446	1,07
817	1,64	3331	1,77	63	2 633	119	1426	1,37
836	4	3431	1,74	61	4 271	121	1458	3,88
812	6	3531	1,79	63	4 468	123	1417	5
936	1,38	3231 MI	1,55	55	1 143	117	1634	1,15
903	1,64	3331	1,61	57	2 568	119	1575	1,37
932	4,8	3431	1,56	55	4 125	121	1626	5
999	1,34	3231 MI	1,45	51	1 130	117	1743	1,12
995	1,67	3331	1,46	52	2 492	119	1736	1,39
1047	5	3431	1,38	49	3 974	121	1827	5
1180	1,45	3231 MI	1,23	44	1 077	117	2059	1,21
1148	1,75	3331	1,26	45	2 386	119	2003	1,46
1171	4	3431	1,24	44	3 834	121	2043	4

87Hz\* 400VY triangle-coupled motor supplied by drive

LS, LSES 1500 min <sup>-1</sup> - 50 Hz		Cb - Gearbox					LS, LSES 2600 min <sup>-1</sup> - 87 Hz	
N <sub>S</sub> (min <sup>-1</sup> )	Kp	Cb / MI-MU	i	M (Nm)	F <sub>R</sub> E/2 (N)	Dim. MI < ——— > page	N <sub>S</sub> (min <sup>-1</sup> )	Kp
<b>7.5 kW - 50 Hz</b>		<i>LSES 132 MU IFT/IE3</i> <i>LS 132 M FFB4 IFT/NIE - LSES 132 MU FFB4 IFT/IE3</i>					<b>13.1 kW - 87 Hz*</b>	
3.75	0.83	3835	386	17887	37,562	147		
4.22	0.93	3835	344	15928	40,535	147		
4.71	1.03	3835	308	14270	42,713	147		
5.50	1.21	3835	264	12213	44,984	147		
5.95	0.88	3733	244	11519	21,972	143		
6.07	1.34	3835	239	11062	46,046	147		
6.69	0.99	3733	217	10251	24,960	143		
6.61	1.46	3833	220	10375	46,608	145		
7.33	1.08	3733	198	9351	27,083	143		
6.88	1.51	3835	211	9755	47,070	147		
7.38	1.63	3833	196	9286	47,390	145		
8.29	1.22	3733	175	8267	29,638	143		
7.90	1.75	3833	184	8675	47,771	145		
9.20	1.36	3733	158	7448	31,569	143		
8.82	1.95	3833	164	7768	48,258	145		
10.3	1.52	3733	141	6641	33,471	143		
9.96	2.20	3833	146	6881	48,644	145		
11.2	1.65	3733	129	6107	34,729	143		
11.2	2.46	3833	130	6138	48,900	145		
13.0	0.83	3633	112	5285	22,382	141		
13.1	1.92	3733	111	5239	36,775	143		
12.6	2.77	3833	115	5441	49,082	145		
15.0	0.96	3633	96.6	4569	24,395	141		
14.3	2.09	3733	102	4805	37,799	143		
14.1	3.09	3833	103	4876	49,190	145		
16.6	1.06	3633	87.3	4130	25,629	141		
16.1	2.35	3733	89.9	4250	39,108	143		
15.8	3.45	3833	92	4348	49,259	145		
18.8	0.83	3533	77.2	3652	10,546	139		
18.9	1.20	3633	76.9	3634	27,023	141		
18.9	2.72	3733	76.8	3628	40,572	143		
17.8	3.89	3833	81.5	3853	49,294	145		
20.8	0.89	3533	69.8	3301	12,762	139		
20.5	1.30	3633	70.8	3350	27,823	141		
21.2	2.93	3733	68.3	3227	41,517	143		
20.2	4	3833	71.7	3389	49,302	145		
23.6	0.97	3533	61.4	2905	15,262	139	41.7	0.81
23.0	1.45	3633	63	2977	28,870	141		
23.0	4.99	3833	63.1	2984	49,289	145		
25.6	1.01	3533	56.6	2678	16,696	139	45.2	0.85
25.8	1.62	3633	56.2	2658	29,767	141		
26.0	5.64	3833	55.7	2632	49,263	145		
29.2	1.27	3533	49.7	2375	18,609	139	51.5	1.26
30.2	1.81	3633	48.1	2296	30,786	141		
30.2	2.72	3733	48	2294	43,718	143		
28.7	6	3833	50.5	2387	49,237	145		

87Hz\* 400VY triangle-coupled motor supplied by drive

Selection tables

Compabloc: Cb / LS, LSES motors / 4 poles

LS, LSES 1500 min <sup>-1</sup> - 50 Hz		Cb - Gearbox					LS, LSES 2600 min <sup>-1</sup> - 87 Hz	
N <sub>S</sub> (min <sup>-1</sup> )	Kp	Cb / MI-MU	i	M (Nm)	F <sub>R</sub> E/2 (N)	Dim. MI < ——— > page	N <sub>S</sub> (min <sup>-1</sup> )	Kp
<b>7.5 kW - 50 Hz</b>		<i>LSES 132 MU IFT/IE3</i> <i>LS 132 M FFB4 IFT/NIE - LSES 132 MU FFB4 IFT/IE3</i>					<b>13.1 kW - 87 Hz*</b>	
34.0	1.47	3533	42.7	2039	20,731	139	60.0	1.46
33.9	1.99	3633	42.8	2043	31,497	141		
33.7	3.26	3733	43	2053	44,285	143		
32.9	7	3833	44.1	2083	49,195	145		
37.9	0.86	3433	38.2	1828	5,408	137	66.9	0.86
37.0	1.60	3533	39.2	1874	21,772	139	65.3	1.58
37.2	2.30	3633	39	1864	32,001	141		
36.1	3.98	3733	40.2	1918	44,604	143		
36.8	8	3833	39.4	1862	49,157	145		
41.9	0.95	3433	34.6	1655	7,728	137	73.9	0.95
42.4	1.83	3533	34.2	1633	23,294	139	74.9	1.81
42.0	2.57	3633	34.5	1648	32,609	141		
40.3	5	3733	36	1717	45,077	143		
41.3	9	3833	35.1	1659	49,118	145		
45.5	1.03	3433	31.9	1525	9,372	137	80.3	1.02
48.1	2.06	3533	30.1	1440	24,513	139	84.9	2.04
46.7	2.81	3633	31.1	1484	33,068	141		
45.5	6	3733	31.8	1521	45,539	143		
45.9	10	3833	31.6	1492	49,082	145		
52.9	1.19	3433	27.4	1310	11,849	137	93.4	1.18
53.6	2.29	3533	27.1	1292	25,064	139	94.6	2.25
52.3	3.11	3633	27.7	1324	33,520	141		
51.0	7	3733	28.4	1357	45,926	143		
52.4	11	3833	27.7	1307	49,039	145		
56.8	1.28	3433	25.5	1221	12,785	137	100	1.27
60.2	2.56	3533	24.1	1150	24,368	139	106	2.47
56.9	3.35	3633	25.5	1217	33,819	141		
57.6	7	3733	25.2	1203	46,289	143		
64.8	1.45	3433	22.4	1069	14,230	137	114	1.44
65.7	2.79	3533	22.1	1054	23,840	139	116	2.64
66.3	3.83	3633	21.9	1044	34,306	141		
64.3	8	3733	22.6	1078	46,584	143		
73.8	0.86	3333	19.6	939	4,137	135	130	0.81
73.3	1.64	3433	19.8	945	15,263	137	129	1.60
76.0	3.04	3533	19.1	911	22,970	139	134	2.89
72.3	4	3633	20	958	34,549	141		
72.1	9	3733	20.1	961	46,859	143		
80.2	0.93	3333	18.1	864	5,415	135	142	0.87
82.4	1.83	3433	17.6	842	16,012	137	145	1.75
84.1	3.52	3533	17.2	824	22,370	139	149	3.13
81.8	5	3633	17.7	847	34,860	141		
81.3	10	3733	17.8	852	47,117	143		
90.3	1.05	3333	16.1	768	6,911	135	159	0.95
91.9	2.04	3433	15.8	754	16,561	137	162	1.91
95.6	3.86	3533	15.2	725	21,616	139	169	3.41
95.8	5	3633	15.1	723	35,208	141		
92.5	11	3733	15.7	749	47,359	143		

87Hz\* 400VY triangle-coupled motor supplied by drive



LS, LSES 1500 min <sup>-1</sup> - 50 Hz		Cb - Gearbox					LS, LSES 2600 min <sup>-1</sup> - 87 Hz	
N <sub>S</sub> (min <sup>-1</sup> )	Kp	Cb / MI-MU	i	M (Nm)	F <sub>R</sub> E/2 (N)	Dim. MI < ——— > page	N <sub>S</sub> (min <sup>-1</sup> )	Kp
<b>7.5 kW - 50 Hz</b>		<i>LSES 132 MU IFT/IE3</i> <i>LS 132 M FFB4 IFT/NIE - LSES 132 MU FFB4 IFT/IE3</i>					<b>13.1 kW - 87 Hz*</b>	
104	1.20	3333	14	669	8,249	135	183	1.05
107	2.37	3433	13.5	645	17,128	137	190	2.12
104	4	3533	14	668	21,140	139	183	3.61
108	6	3633	13.5	643	35,433	141		
105	12	3733	13.8	660	47,570	143		
115	1.33	3333	12.7	605	9,007	135	202	1.15
119	2.60	3433	12.2	584	17,387	137	209	2.26
117	4	3533	12.4	594	20,460	139	206	3.9
112	6	3633	13	620	35,498	141		
119	14	3733	12.2	582	47,753	143		
132	1.44	3333	11	527	9,824	135	232	1.24
134	2.87	3433	10.8	515	17,629	137	237	2.46
131	5	3533	11.1	530	19,819	139	231	4
130	6	3633	11.1	532	35,746	141		
131	15	3733	11	528	47,881	143		
145	1.58	3333	9.98	477	10,286	135	257	1.35
150	3.09	3433	9.67	462	17,469	137	265	2.65
142	6	3633	10.2	488	35,870	141		
150	17	3733	9.64	461	48,039	143		
160	1.69	3333	9.06	433	10,306	135	283	1.45
169	3.33	3433	8.6	411	16,918	137	298	2.85
161	7	3633	9.03	432	36,028	141		
168	18	3733	8.62	412	48,154	143		
181	1.44	3531	8	386	6,825	123	320	1.41
185	1.86	3333	7.85	375	9,979	135	326	1.58
188	3.23	3433	7.69	368	16,393	137	333	3.04
188	9	3633	7.71	369	36,206	141		
189	20	3733	7.68	367	48,260	143		
205	1.21	3333	7.09	339	9,614	135	361	1.22
211	1.63	3531	6.87	331	6,552	123	373	1.59
211	2.86	3433	6.86	328	15,715	137	373	2.76
202	4	3533	7.18	343	17,373	139	357	3.92
211	9	3633	6.86	328	36,320	141		
210	22	3733	6.9	330	48,347	143		
236	1.10	3431	6.15	297	4,954	121	416	1.10
226	1.33	3333	6.41	307	9,390	135	399	1.35
230	1.84	3531	6.31	305	6,402	123	406	1.80
233	3.05	3433	6.21	297	15,284	137	412	2.94
227	4	3533	6.38	305	16,779	139	401	4
234	16	3733	6.21	296	48,426	143		
260	1.22	3431	5.57	269	5,044	121	459	1.23
259	1.53	3333	5.59	267	9,085	135	458	1.55
264	2.11	3531	5.5	265	6,162	123	465	2.06
265	2.98	3433	5.48	262	14,745	137	467	2.87
255	5	3533	5.7	272	16,223	139	449	5
258	18	3733	5.63	269	48,491	143		

87Hz\* 400VY triangle-coupled motor supplied by drive

Selection tables

Compabloc: Cb / LS, LSES motors / 4 poles

LS, LSES 1500 min <sup>-1</sup> - 50 Hz		Cb - Gearbox					LS, LSES 2600 min <sup>-1</sup> - 87 Hz	
N <sub>S</sub> (min <sup>-1</sup> )	Kp	Cb / MI-MU	i	M (Nm)	F <sub>R</sub> E/2 (N)	Dim. MI < ——— > page	N <sub>S</sub> (min <sup>-1</sup> )	Kp
<b>7.5 kW - 50 Hz</b>		<i>LSES 132 MU IFT/IE3</i> <i>LS 132 M FFB4 IFT/NIE - LSES 132 MU FFB4 IFT/IE3</i>					<b>13.1 kW - 87 Hz*</b>	
282	1.32	3431	5.13	248	5,095	121	499	1.34
287	1.69	3333	5.06	242	8,860	135	506	1.71
299	2.38	3531	4.85	234	5,945	123	528	2.25
295	3.51	3433	4.91	235	14,285	137	521	3.38
295	20	3733	4.91	235	48,572	143		
329	1.54	3431	4.41	213	5,152	121	580	1.54
316	1.86	3333	4.59	219	8,644	135	558	1.88
333	2.67	3531	4.35	210	5,763	123	588	2.41
332	3.46	3433	4.37	209	13,807	137	585	3.34
330	22	3733	4.39	210	48,630	143		
367	0.79	3331	3.95	191	1,778	119		
353	1.65	3431	4.11	199	5,149	121	623	1.67
364	2.15	3333	3.98	190	8,325	135	643	2.17
374	2.88	3531	3.88	187	5,570	123	661	2.56
371	3.23	3433	3.91	187	13,357	137	655	3.11
371	25	3733	3.91	187	48,684	143		
412	0.86	3331	3.52	170	1,891	119		
403	1.89	3431	3.6	174	5,143	121	711	1.90
408	3.16	3531	3.55	171	5,413	123	721	2.67
412	27	3733	3.52	168	48,729	143		
459	0.90	3331	3.16	153	1,960	119		
456	2.13	3431	3.18	154	5,009	121	805	2.11
472	3.19	3531	3.07	148	5,196	123	834	2.90
470	31	3733	3.08	147	48,778	143		
498	1.05	3331	2.91	141	2,004	119	880	0.89
512	2.37	3431	2.83	137	4,843	121	904	2.30
523	3.56	3531	2.77	134	5,026	123	923	2.99
561	1.20	3331	2.58	125	2,057	119	991	1.04
571	2.57	3431	2.54	123	4,687	121	1008	2.49
594	3.78	3531	2.44	118	4,845	123	1049	3.16
644	1.21	3331	2.25	109	2,087	119	1138	1.02
667	2.85	3431	2.17	105	4,475	121	1178	2.76
644	3.91	3531	2.25	109	4,723	123	1138	3.27
712	1.28	3331	2.04	98	2,111	119	1258	1.07
737	3.05	3431	1.97	95	4,343	121	1301	2.94
725	4	3531	2	97	4,553	123	1280	3.43
817	1.20	3331	1.77	86	2,093	119	1443	1.01
836	2.98	3431	1.74	84	4,178	121	1475	2.87
812	4	3531	1.79	86	4,397	123	1434	3.57
903	1.20	3331	1.61	78	2,077	119	1594	1.01
932	3.51	3431	1.56	75	4,040	121	1646	3.38
995	1.22	3331	1.46	70	2,078	119	1757	1.02
1047	3.46	3431	1.38	67	3,894	121	1849	3.34
1148	1.28	3331	1.26	61	2,030	119	2027	1.07
1171	3.23	3431	1.24	60	3,758	121	2068	3.11

87Hz\* 400VY triangle-coupled motor supplied by drive

LS, LSES 1500 min <sup>-1</sup> - 50 Hz		Cb - Gearbox					LS, LSES 2600 min <sup>-1</sup> - 87 Hz	
N <sub>S</sub> (min <sup>-1</sup> )	Kp	Cb / MI-MU	i	M (Nm)	F <sub>R</sub> E/2 (N)	Dim. MI < ——— > page	N <sub>S</sub> (min <sup>-1</sup> )	Kp
<b>9 kW - 50 Hz</b>		LSES 160 MR IFT/IE3 LS 132 M FFB4 IFT/NIE - LSES 160 MR FFB4 IFT/IE3					<b>15.7 kW - 87 Hz*</b>	
4.69	0.86	3835	308	17191	38,669	147		
5.48	1.00	3835	264	14712	42,163	147		
6.05	1.11	3835	239	13326	43,815	147		
6.66	0.82	3733*	217	12351	20,011	143		
6.58	1.21	3833*	220	12500	44,696	145		
7.30	0.90	3733*	198	11266	22,568	143		
6.86	1.26	3835	211	11752	45,427	147		
7.35	1.36	3833*	196	11189	45,936	145		
8.26	1.01	3733*	175	9960	25,647	143		
7.87	1.45	3833*	184	10452	46,547	145		
9.17	1.13	3733*	158	8973	27,974	143		
8.79	1.62	3833*	164	9359	47,342	145		
10.3	1.26	3733*	141	8001	30,265	143		
9.93	1.83	3833*	146	8290	47,989	145		
11.2	1.37	3733*	129	7358	31,781	143		
11.1	2.05	3833	130	7395	48,431	145		
13.0	1.59	3733*	111	6312	34,246	143		
12.6	2.30	3833	115	6556	48,764	145		
15.0	0.79	3633*	96.6	5504	21,765	141		
14.2	1.73	3733	102	5789	35,479	143		
14.0	2.56	3833	103	5875	48,975	145		
16.5	0.88	3633	87.3	4976	23,252	141		
16.1	1.95	3733	89.9	5120	37,056	143		
15.7	2.87	3833	92	5238	49,125	145		
18.8	0.99	3633	76.9	4378	24,931	141		
18.8	2.26	3733	76.8	4371	38,820	143		
17.7	3.23	3833	81.5	4642	49,225	145		
20.4	1.08	3633	70.8	4035	25,895	141		
21.2	2.44	3733	68.3	3888	39,959	143		
20.2	3.66	3833	71.7	4083	49,281	145		
23.0	1.21	3633	63	3587	27,156	141		
23.6	2.61	3733	61.2	3487	40,906	143		
22.9	4	3833	63.1	3595	49,302	145		
25.7	1.35	3633	56.2	3203	28,237	141		
26.1	2.76	3733	55.4	3153	41,693	143		
26.0	5	3833	55.7	3171	49,298	145		
28.7	0.90	3533*	50.3	2867	15,502	139		
28.7	1.50	3633	50.4	2870	29,173	141		
30.1	2.26	3733*	48	2763	42,611	143		
28.6	5	3833	50.5	2876	49,283	145		
32.2	0.96	3533*	44.9	2560	17,441	139	56.9	0.80
33.8	1.65	3633*	42.8	2462	30,320	141		
33.6	2.71	3733*	43	2473	43,294	143		
33.4	2.87	3833*	43.6	2488	49,251	145		

Cb 3533\*, Cb 3633\*, Cb 3733\*, Cb 3833\*: MI, compulsory integral mounting for frame 132

87Hz\* 400VY triangle-coupled motor supplied by drive

LS, LSES 1500 min <sup>-1</sup> - 50 Hz		Cb - Gearbox					LS, LSES 2600 min <sup>-1</sup> - 87 Hz	
N <sub>S</sub> (min <sup>-1</sup> )	K <sub>p</sub>	Cb / MI-MU	i	M (Nm)	F <sub>R</sub> E/2 (N)	Dim. MI < ——— > page	N <sub>S</sub> (min <sup>-1</sup> )	K <sub>p</sub>
<b>9 kW - 50 Hz</b>		<i>LSES 160 MR IFT/IE3</i> <i>LS 132 M FFB4 IFT/NIE - LSES 160 MR FFB4 IFT/IE3</i>					<b>15.7 kW - 87 Hz*</b>	
35.9	1.02	3533*	40.3	2294	19,121	139	63.5	0.86
37.0	1.91	3633*	39	2245	30,928	141		
36.0	3.31	3733*	40.2	2311	43,678	143		
41.4	0.79	3433*	34.9	1987	3,159	137	73.3	0.79
42.3	1.52	3533*	34.2	1967	21,185	139	74.8	1.51
41.9	2.13	3633*	34.5	1985	31,660	141		
40.2	3.87	3733*	36	2069	44,248	143		
46.3	0.88	3433*	31.2	1777	6,107	137	81.9	0.88
47.9	1.71	3533*	30.1	1735	22,650	139	84.8	1.70
46.5	2.34	3633*	31.1	1788	32,213	141		
45.4	5	3733*	31.8	1833	44,805	143		
47.0	6	3833	30.8	1770	49,140	145		
52.7	0.99	3433*	27.4	1578	8,704	137	93.2	0.99
53.4	1.90	3533*	27.1	1557	23,774	139	94.5	1.87
52.2	2.59	3633*	27.7	1595	32,758	141		
50.9	5	3733	28.4	1635	45,271	143		
52.6	7	3833	27.5	1582	49,102	145		
56.6	1.06	3433*	25.5	1471	10,021	137	100	1.06
60.0	2.13	3533*	24.1	1386	23,743	139	106	2.05
56.7	2.78	3633*	25.5	1466	33,119	141		
57.4	6	3733	25.2	1449	45,709	143		
58.9	9	3833	24.5	1412	49,064	145		
64.6	1.21	3433*	22.4	1288	12,088	137	114	1.20
65.5	2.31	3533*	22.1	1270	23,270	139	116	2.20
66.1	3.18	3633*	21.9	1258	33,705	141		
64.0	7	3733	22.6	1299	46,064	143		
65.9	10	3833	21.9	1262	49,028	145		
73.1	1.36	3433*	19.8	1138	13,595	137	129	1.33
75.8	2.52	3533*	19.1	1098	22,480	139	134	2.40
72.1	3.43	3633	20	1154	33,998	141		
71.8	7	3733	20.1	1158	46,395	143		
74.0	10	3833	19.5	1124	48,993	145		
82.1	1.52	3433*	17.6	1014	14,709	137	145	1.46
83.8	2.93	3533*	17.2	992	21,930	139	148	2.61
81.5	3.82	3633	17.7	1020	34,373	141		
81.0	8	3733	17.8	1026	46,706	143		
83.1	12	3833	17.4	1000	48,959	145		
91.6	1.69	3433*	15.8	908	15,541	137	162	1.59
95.3	3.2	3533*	15.2	873	21,230	139	168	2.84
95.5	4	3633	15.1	871	34,792	141		
92.1	9	3733	15.7	903	46,997	143		
93.9	13	3833	15.4	886	48,927	145		

Cb 3433\*, Cb 3533\*, Cb 3633\*, Cb 3733\*: MI, compulsory integral mounting for frame 132

LS, LSES 1500 min <sup>-1</sup> - 50 Hz		Cb - Gearbox					LS, LSES 2600 min <sup>-1</sup> - 87 Hz	
N <sub>S</sub> (min <sup>-1</sup> )	Kp	Cb / MI-MU	i	M (Nm)	F <sub>R</sub> E/2 (N)	Dim. MI < ——— > page	N <sub>S</sub> (min <sup>-1</sup> )	Kp
<b>9 kW - 50 Hz</b>		<i>LSES 160 MR IFT/IE3</i> <i>LS 132 M FFB4 IFT/NIE - LSES 160 MR FFB4 IFT/IE3</i>					<b>15.7 kW - 87 Hz*</b>	
107	1.96	3433*	13.5	777	16,422	137	189	1.77
103	3.37	3533*	14	805	20,786	139	183	3.00
107	5	3633	13.5	775	35,063	141		
105	10	3733	13.8	795	47,252	143		
105	14	3833	13.7	788	48,898	145		
118	2.16	3433*	12.2	704	16,837	137	209	1.89
116	3.73	3533*	12.4	715	20,150	139	206	3.25
120	5	3633	12.1	695	35,288	141		
119	11	3733	12.2	701	47,473	143		
116	15	3833	12.5	718	48,876	145		
134	2.38	3433*	10.8	621	17,237	137	237	2.05
130	3.98	3533*	11.1	639	19,540	139	230	3.51
132	6	3633	10.9	628	35,475	141		
131	12	3733	11	636	47,626	143		
131	17	3833	11	635	48,850	145		
149	2.57	3433*	9.67	557	17,169	137	264	2.21
145	4	3533*	9.94	572	18,960	139	257	3.77
150	7	3633	9.63	554	35,683	141		
150	14	3733	9.64	555	47,817	143		
145	18	3833	9.96	573	48,830	145		
168	2.77	3433*	8.6	495	16,654	137	297	2.38
159	5	3533*	9.07	522	18,480	139	282	4
169	7	3633	8.53	491	35,862	141		
168	15	3733	8.62	496	47,956	143		
165	20	3833	8.75	504	48,807	145		
188	2.68	3433*	7.69	443	16,159	137	332	2.53
182	5	3533*	7.92	456	17,785	139	322	4
190	8	3633	7.62	439	36,009	141		
188	17	3733	7.68	442	48,083	143		
211	2.37	3433*	6.86	395	15,477	137	372	2.30
201	3.37	3533*	7.18	413	17,180	139	356	3.26
211	8	3633	6.86	395	36,132	141		
233	2.53	3433*	6.21	358	15,068	137	411	2.45
226	3.73	3533*	6.38	367	16,610	139	400	3.60
235	9	3633	6.15	354	36,246	141		
233	13	3733	6.21	357	48,283	143		
263	1.75	3531*	5.5	320	6,042	123	465	1.72
264	2.47	3433*	5.48	316	14,555	137	466	2.39
254	4	3533*	5.7	328	16,072	139	448	3.84
262	10	3633	5.56	317	36,342	141		
257	15	3733	5.63	324	48,361	143		

Cb 3433\*, Cb 3531\*, Cb 3533\*: MI, compulsory integral mounting for frame 132

Selection tables

Compabloc: Cb / LS, LSES motors / 4 poles

LS, LSES 1500 min <sup>-1</sup> - 50 Hz		Cb - Gearbox					LS, LSES 2600 min <sup>-1</sup> - 87 Hz	
N <sub>S</sub> (min <sup>-1</sup> )	K <sub>p</sub>	Cb / MI-MU	i	M (Nm)	F <sub>R</sub> E/2 (N)	Dim. MI < ——— > page	N <sub>S</sub> (min <sup>-1</sup> )	K <sub>p</sub>
<b>9 kW - 50 Hz</b>		<i>LSES 160 MR IFT/IE3</i> <i>LS 132 M FFB4 IFT/NIE - LSES 160 MR FFB4 IFT/IE3</i>					<b>15.7 kW - 87 Hz*</b>	
298	1.97	3531*	4.85	282	5,838	123	527	1.88
294	2.91	3433*	4.91	283	14,117	137	520	2.81
283	5	3533*	5.1	294	15,562	139	501	5
294	11	3633	4.91	283	36,448	141		
294	17	3733	4.91	283	48,458	143		
328	1.28	3431*	4.41	257	4,350	121	579	1.28
332	2.21	3531*	4.35	253	5,665	123	587	2.01
330	2.88	3433*	4.37	252	13,658	137	584	2.78
310	5	3533*	4.66	268	15,145	139	549	5
333	12	3633	4.34	250	36,539	141		
329	19	3733	4.39	253	48,529	143		
351	1.37	3431*	4.11	239	4,411	121	621	1.39
373	2.39	3531*	3.88	225	5,482	123	659	2.13
370	2.68	3433*	3.91	225	13,226	137	653	2.59
355	6	3533*	4.07	234	14,545	139	628	6
372	12	3633	3.88	224	36,613	141		
369	21	3733	3.91	225	48,594	143		
401	1.57	3431*	3.6	209	4,479	121	710	1.59
407	2.63	3531*	3.55	206	5,328	123	720	2.23
454	1.77	3431*	3.18	185	4,496	121	803	1.76
471	2.65	3531*	3.07	178	5,123	123	833	2.41
510	1.97	3431*	2.83	165	4,487	121	902	1.92
521	2.96	3531*	2.77	161	4,956	123	921	2.49
569	2.13	3431*	2.54	148	4,460	121	1007	2.07
592	3.14	3531*	2.44	142	4,784	123	1047	2.64
665	2.4	3431*	2.17	126	4,401	121	1176	2.3
642	3.25	3531*	2.25	131	4,667	123	1136	2.73
734	2.53	3431*	1.97	114	4,274	121	1298	2.45
723	3.40	3531*	2	116	4,503	123	1278	2.85
833	2.47	3431*	1.74	101	4,113	121	1472	2.39
809	3.54	3531*	1.79	104	4,346	123	1431	2.98
929	2.91	3431*	1.56	90	3,981	121	1643	2.81
903	3.68	3531*	1.6	93	4,200	123	1597	3.09
1044	2.88	3431*	1.38	81	3,837	121	1845	2.78
990	3.79	3531*	1.46	85	4,080	123	1751	3.18
1167	2.68	3431*	1.24	72	3,707	121	2064	2.59
1133	3.94	3531*	1.28	74	3,911	123	2004	3.31

Cb 34\*, Cb 35\*: MI, compulsory integral mounting for frame 132

LS, LSES 1500 min <sup>-1</sup> - 50 Hz		Cb - Gearbox					LS, LSES 2600 min <sup>-1</sup> - 87 Hz	
N <sub>S</sub> (min <sup>-1</sup> )	Kp	Cb / MI-MU	i	M (Nm)	F <sub>R</sub> E/2 (N)	Dim. MI < ——— > page	N <sub>S</sub> (min <sup>-1</sup> )	Kp
<b>11 kW - 50 Hz</b>		<i>LSES 160 M IFT/IE3</i> <i>LS 160 MP FFB5 IFT/NIE - LSES 160 M FFB5 IFT/IE3</i>					<b>19.1 kW - 87 Hz*</b>	
5.51	0.83	3835	264	17901	37,540	147		
6.08	0.91	3835	239	16215	40,128	147		
6.61	1.00	3833	220	15211	41,515	145		
6.89	1.03	3835	211	14299	42,678	147		
7.39	1.11	3833	196	13615	43,488	145		
8.30	0.83	3733	175	12121	20,554	143		
7.91	1.19	3833	184	12720	44,469	145		
9.21	0.92	3733	158	10919	23,386	143		
8.83	1.33	3833	164	11389	45,759	145		
10.3	1.04	3733	141	9736	26,174	143		
9.97	1.50	3833	146	10089	46,827	145		
11.2	1.13	3733	129	8954	28,019	143		
11.2	1.68	3833	130	8999	47,575	145		
13.1	1.31	3733	111	7681	31,019	143		
12.6	1.89	3833	115	7978	48,154	145		
14.3	1.42	3733	102	7045	32,519	143		
14.1	2.11	3833	103	7149	48,537	145		
16.2	1.60	3733	89.9	6230	34,438	143		
15.8	2.36	3833	92	6374	48,825	145		
18.9	0.82	3633	76.9	5328	22,261	141		
18.9	1.86	3733	76.8	5320	36,585	143		
17.8	2.65	3833	81.5	5649	49,034	145		
20.5	0.88	3633	70.8	4910	23,435	141		
21.3	2.00	3733	68.3	4732	37,971	143		
20.3	3.00	3833	71.7	4968	49,175	145		
23.1	0.99	3633	63	4365	24,969	141		
23.7	2.14	3733	61.2	4243	39,123	143		
23.0	3.40	3833	63.1	4374	49,256	145		
25.8	1.11	3633	56.2	3897	26,284	141		
26.2	2.26	3733	55.4	3837	40,081	143		
26.1	3.84	3833	55.7	3858	49,294	145		
28.8	1.23	3633	50.4	3492	27,423	141		
29.7	2.43	3733	48.8	3385	41,146	143		
28.8	4	3833	50.5	3500	49,303	145		
32.3	0.79	3533	44.9	3115	13,936	139		
34.0	1.36	3633	42.8	2995	28,819	141		
33.3	2.34	3833	43.6	3055	49,293	145		
33.6	2.61	3733	43.2	2996	42,062	143		
36.1	0.84	3533	40.3	2791	15,982	139		
37.2	1.57	3633	39	2732	29,559	141		
36.2	2.72	3733	40.2	2812	42,497	143		
37.3	2.91	3833	38.9	2725	49,271	145		



LS, LSES 1500 min <sup>-1</sup> - 50 Hz		Cb - Gearbox					LS, LSES 2600 min <sup>-1</sup> - 87 Hz	
N <sub>S</sub> (min <sup>-1</sup> )	Kp	Cb / MI-MU	i	M (Nm)	F <sub>R</sub> E/2 (N)	Dim. MI < ——— > page	N <sub>S</sub> (min <sup>-1</sup> )	Kp
<b>11 kW - 50 Hz</b>		<i>LSES 160 M IFT/IE3</i> <i>LS 160 MP FFB5 IFT/NIE - LSES 160 M FFB5 IFT/IE3</i>					<b>19.1 kW - 87 Hz*</b>	
42.5	1.24	3533	34.2	2394	18,489	139	74.6	1.24
42.1	1.75	3633	34.5	2416	30,450	141		
40.4	3.18	3733	36	2518	43,190	143		
42.2	3.82	3833	34.4	2409	49,239	145		
48.2	1.41	3533	30.1	2111	20,276	139	84.6	1.39
46.7	1.92	3633	31.1	2176	31,123	141		
45.6	3.89	3733	31.8	2230	43,868	143		
47.2	5	3833	30.8	2153	49,205	145		
53.0	0.81	3433	27.4	1921	4,107	137	93.0	0.81
53.7	1.56	3533	27.1	1895	21,640	139	94.3	1.54
52.4	2.12	3633	27.7	1940	31,786	141		
51.1	4	3733	28.4	1989	44,436	143		
52.8	6	3833	27.5	1925	49,168	145		
56.8	0.87	3433	25.5	1790	5,929	137	99.8	0.87
60.3	1.75	3533	24.1	1687	22,860	139	106	1.68
57.0	2.28	3633	25.5	1784	32,224	141		
57.7	5	3733	25.2	1764	44,968	143		
59.2	7	3833	24.5	1718	49,130	145		
64.9	0.99	3433	22.4	1567	8,844	137	114	0.98
65.8	1.90	3533	22.1	1545	22,463	139	116	1.80
66.4	2.61	3633	21.9	1531	32,938	141		
64.3	5	3733	22.6	1580	45,400	143		
66.2	8	3833	21.9	1535	49,092	145		
73.4	1.12	3433	19.8	1385	11,019	137	129	1.10
76.1	2.07	3533	19.1	1336	21,777	139	134	1.97
72.4	2.81	3633	20	1404	33,294	141		
72.2	6	3733	20.1	1409	45,803	143		
74.3	8	3833	19.5	1368	49,054	145		
82.5	1.25	3433	17.6	1233	12,658	137	145	1.20
84.2	2.40	3533	17.2	1207	21,292	139	148	2.14
81.9	3.13	3633	17.7	1242	33,751	141		
81.4	7	3733	17.8	1249	46,181	143		
83.5	10	3833	17.4	1217	49,017	145		
92.1	1.39	3433	15.8	1105	13,906	137	162	1.31
95.7	2.63	3533	15.2	1062	20,667	139	168	2.33
95.9	3.60	3633	15.1	1060	34,261	141		
92.6	7	3733	15.7	1098	46,536	143		
94.4	10	3833	15.4	1078	48,980	145		
107.6	1.61	3433	13.5	946	15,257	137	189	1.45
103.9	2.77	3533	14	979	20,264	139	182	2.46
107.8	3.99	3633	13.5	943	34,590	141		
105.1	8	3733	13.8	967	46,845	143		
106.0	12	3833	13.7	959	48,948	145		

LS, LSES 1500 min <sup>-1</sup> - 50 Hz		Cb - Gearbox					LS, LSES 2600 min <sup>-1</sup> - 87 Hz	
N <sub>S</sub> (min <sup>-1</sup> )	Kp	Cb / MI-MU	i	M (Nm)	F <sub>R</sub> E/2 (N)	Dim. MI < — > page	N <sub>S</sub> (min <sup>-1</sup> )	Kp
<b>11 kW - 50 Hz</b>		<i>LSES 160 M IFT/IE3</i> <i>LS 160 MP FFB5 IFT/NIE - LSES 160 M FFB5 IFT/IE3</i>					<b>19.1 kW - 87 Hz*</b>	
118.7	1.77	3433	12.2	857	15,909	137	209	1.55
116.8	3.06	3533	12.4	870	19,683	139	205	2.67
120.3	4	3633	12.1	846	34,864	141		
119.2	9	3733	12.2	853	47,114	143		
116.4	12	3833	12.5	874	48,923	145		
134.7	1.95	3433	10.8	755	16,552	137	236	1.68
131	3.27	3533	11.1	777	19,122	139	230	2.88
133	5	3633	10.9	765	35,092	141		
131	10	3733	11	774	47,301	143		
132	14	3833	11	773	48,893	145		
150	2.11	3433	9.67	677	16,730	137	264	1.81
146	3.61	3533	9.94	696	18,583	139	256	3.09
151	5	3633	9.63	675	35,345	141		
151	11	3733	9.64	675	47,533	143		
146	15	3833	9.96	698	48,870	145		
169	2.27	3433	8.6	603	16,258	137	296	1.95
160	3.84	3533	9.07	635	18,133	139	281	3.29
170	6	3633	8.53	597	35,563	141		
168	12	3733	8.62	604	47,702	143		
166	16	3833	8.75	613	48,843	145		
189	2.20	3433	7.69	539	15,805	137	331	2.08
183	4.19	3533	7.92	555	17,479	139	322	3.59
191	7	3633	7.62	534	35,741	141		
189	14	3733	7.68	538	47,858	143		
179	17	3833	8.11	568	48,828	145		
212	1.95	3433	6.86	481	15,118	137	372	1.89
202	2.77	3533	7.18	503	16,877	139	355	2.67
212	6	3633	6.86	481	35,891	141		
210	15	3733	6.9	484	47,985	143		
209	20	3833	6.95	486	48,801	145		
234	2.08	3433	6.21	435	14,744	137	410	2.01
228	3.06	3533	6.38	447	16,339	139	400	2.95
236	8	3633	6.15	431	36,030	141		
234	11	3733	6.21	435	48,100	143		
229	21	3833	6.33	443	48,787	145		
264	1.44	3531	5.5	389	5,551	123	464	1.41
265	2.03	3433	5.48	384	14,267	137	465	1.96
255	3.27	3533	5.7	399	15,829	139	448	3.15
261	8	3633	5.56	390	36,146	141		
258	12	3733	5.63	394	48,196	143		
262	25	3833	5.55	388	48,768	145		
299	1.62	3531	4.85	343	5,609	123	526	1.54
296	2.39	3433	4.91	344	13,858	137	519	2.31
284	4	3533	5.1	358	15,340	139	500	4

87Hz\* 400VY triangle-coupled motor supplied by drive

LS, LSES 1500 min <sup>-1</sup> - 50 Hz		Cb - Gearbox					LS, LSES 2600 min <sup>-1</sup> - 87 Hz	
N <sub>S</sub> (min <sup>-1</sup> )	Kp	Cb / MI-MU	i	M (Nm)	F <sub>R</sub> E/2 (N)	Dim. MI < ——— > page	N <sub>S</sub> (min <sup>-1</sup> )	Kp
<b>11 kW - 50 Hz</b>		<i>LSES 160 M IFT/IE3</i> <i>LS 160 MP FFB5 IFT/NIE - LSES 160 M FFB5 IFT/IE3</i>					<b>19.1 kW - 87 Hz*</b>	
296	9	3633	4.91	344	36,275	141		
295	14	3733	4.91	344	48,314	143		
290	27	3833	5.01	351	48,754	145		
329	1.05	3431	4.41	312	3,320	121	578	1.05
334	1.82	3531	4.4	308	5,521	123	586	1.65
332	2.36	3433	4.37	306	13,426	137	583	2.28
312	5	3533	4.7	326	14,942	139	548	4
334	10	3633	4.34	304	36,386	141		
331	15	3733	4.39	308	48,400	143		
330	30	3833	4.4	308	48,739	145		
353	1.13	3431	4.11	291	3,425	121	620	1.14
375	1.97	3531	3.88	274	5,350	123	658	1.75
371	2.20	3433	3.91	274	13,015	137	652	2.12
357	5	3533	4.07	285	14,365	139	627	5
374	10	3633	3.88	272	36,477	141		
371	17	3733	3.91	274	48,479	143		
356	30	3833	4.08	285	48,731	145		
403	1.29	3431	3.6	255	3,581	121	708	1.30
409	2.16	3531	3.55	251	5,199	123	718	1.83
413	19	3733	3.52	246	48,544	143		
416	31	3833	3.49	244	48,716	145		
456	1.46	3431	3.18	225	3,693	121	801	1.44
473	2.17	3531	3.07	217	5,011	123	831	1.98
471	21	3733	3.08	216	48,616	143		
456	27	3833	3.18	223	48,709	145		
512	1.62	3431	2.83	201	3,741	121	900	1.57
523	2.43	3531	2.77	196	4,849	123	919	2.05
505	30	3833	2.88	202	48,701	145		
572	1.75	3431	2.54	180	3,776	121	1005	1.70
595	2.57	3531	2.44	173	4,688	123	1045	2.16
668	1.95	3431	2.17	154	3,785	121	1174	1.89
645	2.66	3531	2.25	159	4,578	123	1133	2.24
738	2.08	3431	1.97	139	3,782	121	1296	2.01
726	2.79	3531	2	142	4,417	123	1275	2.34
837	2.03	3431	1.74	123	3,735	121	1469	1.96
813	2.91	3531	1.79	126	4,271	123	1428	2.44
933	2.39	3431	1.56	110	3,695	121	1639	2.31
908	3.02	3531	1.6	113	4,128	123	1594	2.54
1049	2.36	3431	1.38	98	3,630	121	1842	2.28
995	3.11	3531	1.46	103	4,013	123	1747	2.61
1173	2.20	3431	1.24	88	3,551	121	2060	2.12
1139	3.24	3531	1.28	90	3,847	123	2000	2.72

87Hz\* 400VY triangle-coupled motor supplied by drive

LS, LSES 1500 min <sup>-1</sup> - 50 Hz		Cb - Gearbox					LS, LSES 2600 min <sup>-1</sup> - 87 Hz	
N <sub>S</sub> (min <sup>-1</sup> )	Kp	Cb / MI-MU	i	M (Nm)	F <sub>R</sub> E/2 (N)	Dim. MI < ——— > page	N <sub>S</sub> (min <sup>-1</sup> )	Kp
<b>15 kW - 50 Hz</b>		<i>LSES 160 LUR IFT/IE3</i> <i>LS 160 LR FFB5 IFT/NIE - LSES 160 LUR FFB5 IFT/IE3</i>					<b>26.1 kW - 87 Hz*</b>	
7.40	0.82	3833	196	18552	36,455	145		
7.92	0.87	3833	184	17331	38,450	145		
8.85	0.98	3833	164	15518	41,102	145		
9.99	1.10	3833	146	13746	43,337	145		
11.3	0.83	3733	129	12200	20,367	143		
11.2	1.23	3833	130	12262	44,936	145		
13.1	0.96	3733	111	10466	24,454	143		
12.6	1.39	3833	115	10870	46,208	145		
14.3	1.04	3733	102	9599	26,498	143		
14.1	1.55	3833	103	9741	47,080	145		
16.2	1.18	3733	89.9	8489	29,114	143		
15.8	1.73	3833	92	8685	47,765	145		
18.9	1.36	3733	76.8	7248	32,039	143		
17.8	1.95	3833	81.5	7697	48,292	145		
21.3	1.47	3733	68.3	6447	33,927	143		
20.3	2.20	3833	71.7	6769	48,687	145		
23.8	1.57	3733	61.2	5781	35,497	143		
23.0	2.50	3833	63.1	5960	48,951	145		
25.9	0.81	3633	56.2	5310	22,312	141		
26.3	1.66	3733	55.4	5228	36,803	143		
26.1	2.82	3833	55.7	5257	49,122	145		
28.9	0.90	3633	50.4	4758	23,865	141		
29.8	1.79	3733	48.8	4612	38,253	143		
28.8	3.10	3833	50.5	4768	49,207	145		
34.0	1.00	3633	42.8	4081	25,767	141		
33.3	1.72	3833	43.6	4163	49,275	145		
33.6	1.91	3733	43.2	4083	39,501	143		
37.3	1.15	3633	39	3723	26,775	141		
36.2	1.99	3733	40.2	3831	40,094	143		
37.4	2.13	3833	38.9	3712	49,299	145		
42.5	0.91	3533	34.2	3261	13,014	139	74.9	0.91
42.2	1.28	3633	34.5	3291	27,988	141		
40.4	2.33	3733	36	3430	41,039	143		
42.3	2.81	3833	34.4	3282	49,301	145		
48.2	1.03	3533	30.1	2876	15,445	139	84.9	1.02
46.8	1.41	3633	31.1	2965	28,905	141		
45.7	2.85	3733	31.8	3039	41,962	143		
47.3	3.85	3833	30.8	2934	49,287	145		
53.8	1.15	3533	27.1	2581	17,308	139	94.6	1.13
52.5	1.56	3633	27.7	2644	29,808	141		
51.2	3.26	3733	28.4	2711	42,736	143		
52.9	4.46	3833	27.5	2623	49,262	145		
60.4	1.28	3533	24.1	2298	19,095	139	106	1.24
57.1	1.68	3633	25.5	2431	30,406	141		
57.7	3.62	3733	25.2	2403	43,461	143		
59.3	5	3833	24.5	2341	49,231	145		
65.9	1.40	3533	22.1	2105	20,314	139	116	1.32
66.5	1.92	3633	21.9	2086	31,377	141		
64.4	3.97	3733	22.6	2153	44,049	143		
66.3	6	3833	21.9	2092	49,196	145		

LS, LSES 1500 min <sup>-1</sup> - 50 Hz		Cb - Gearbox					LS, LSES 2600 min <sup>-1</sup> - 87 Hz	
N <sub>S</sub> (min <sup>-1</sup> )	Kp	Cb / MI-MU	i	M (Nm)	F <sub>R</sub> E/2 (N)	Dim. MI < ——— > page	N <sub>S</sub> (min <sup>-1</sup> )	Kp
<b>15 kW - 50 Hz</b>		<i>LSES 160 LUR IFT/IE3</i> <i>LS 160 LR FFB5 IFT/NIE - LSES 160 LUR FFB5 IFT/IE3</i>					<b>26.1 kW - 87 Hz*</b>	
73.5	0.82	3433	19.8	1887	4,580	137	129	0.80
76.2	1.52	3533	19.1	1820	20,417	139	134	1.45
72.5	2.07	3633	20	1913	31,863	141		
72.3	4	3733	20.1	1920	44,599	143		
74.4	6	3833	19.5	1864	49,158	145		
82.6	0.92	3433	17.6	1680	7,393	137	145	0.88
84.3	1.76	3533	17.2	1645	20,060	139	149	1.57
82.0	2.3	3633	17.7	1692	32,485	141		
81.5	5	3733	17.8	1701	45,114	143		
83.7	7	3833	17.4	1658	49,118	145		
92.2	1.02	3433	15.8	1506	9,605	137	162	0.96
95.9	1.93	3533	15.2	1448	19,580	139	169	1.71
96.1	2.64	3633	15.1	1444	33,180	141		
92.7	5	3733	15.7	1496	45,597	143		
94.5	8	3833	15.4	1468	49,077	145		
108	1.18	3433	13.5	1288	12,084	137	190	1.06
104	2.03	3533	14	1334	19,265	139	183	1.81
108	2.93	3633	13.5	1285	33,629	141		
105	6	3733	13.8	1318	46,019	143		
106	8	3833	13.7	1307	49,039	145		
119	1.30	3433	12.2	1167	13,321	137	209	1.14
117	2.25	3533	12.4	1186	18,793	139	206	1.96
120	3.22	3633	12.1	1152	34,003	141		
119	7	3733	12.2	1162	46,385	143		
117	9	3833	12.5	1191	49,010	145		
135	1.43	3433	10.8	1029	14,578	137	237	1.24
131	2.40	3533	11.1	1059	18,327	139	231	2.11
133	3.52	3633	10.9	1042	34,313	141		
132	7	3733	11	1054	46,640	143		
132	10	3833	11	1053	48,974	145		
150	1.55	3433	9.67	923	15,434	137	265	1.33
146	2.65	3533	9.94	949	17,869	139	257	2.27
151	3.93	3633	9.63	919	34,658	141		
151	8	3733	9.64	920	46,956	143		
146	11	3833	9.96	951	48,945	145		
169	1.67	3433	8.6	821	15,510	137	298	1.43
160	2.82	3533	9.07	865	17,484	139	282	2.41
171	4	3633	8.53	814	34,954	141		
169	9	3733	8.62	822	47,186	143		
166	12	3833	8.75	835	48,912	145		
189	1.62	3433	7.69	734	15,136	137	333	1.52
184	3.08	3533	7.92	756	16,910	139	323	2.63
191	5	3633	7.62	727	35,197	141		
189	10	3733	7.68	732	47,398	143		
179	12	3833	8.11	774	48,893	145		
212	1.43	3433	6.86	655	14,439	137	373	1.38
203	2.03	3533	7.18	685	16,314	139	357	1.96
212	4.55	3633	6.86	655	35,401	141		
211	11	3733	6.9	659	47,572	143		
209	14	3833	6.95	663	48,859	145		

LS, LSES 1500 min <sup>-1</sup> - 50 Hz		Cb - Gearbox					LS, LSES 2600 min <sup>-1</sup> - 87 Hz	
N <sub>S</sub> (min <sup>-1</sup> )	Kp	Cb / MI-MU	i	M (Nm)	F <sub>R</sub> E/2 (N)	Dim. MI < — > page	N <sub>S</sub> (min <sup>-1</sup> )	Kp
<b>15 kW - 50 Hz</b>		<i>LSES 160 LUR IFT/IE3</i> <i>LS 160 LR FFB5 IFT/NIE - LSES 160 LUR FFB5 IFT/IE3</i>					<b>26.1 kW - 87 Hz*</b>	
234	1.53	3433	6.21	593	14,128	137	412	1.48
228	2.25	3533	6.38	609	15,837	139	401	2.17
236	6	3633	6.15	587	35,591	141		
234	8	3733	6.21	592	47,729	143		
230	15	3833	6.33	604	48,840	145		
264	1.06	3531	5.5	530	3,798	123	465	1.03
265	1.49	3433	5.48	523	13,724	137	467	1.44
255	2.40	3533	5.7	544	15,379	139	449	2.31
261	6	3633	5.56	531	35,749	141		
258	9	3733	5.63	537	47,859	143		
262	18	3833	5.55	529	48,815	145		
300	1.19	3531	4.85	468	4,021	123	528	1.13
296	1.76	3433	4.91	469	13,369	137	521	1.69
285	3.15	3533	5.1	487	14,940	139	501	3.03
296	7	3633	4.91	468	35,925	141		
296	10	3733	4.91	469	48,020	143		
290	20	3833	5.01	478	48,798	145		
334	1.33	3531	4.35	420	4,173	123	588	1.21
333	1.73	3433	4.37	417	12,992	137	585	1.67
312	3.31	3533	4.66	444	14,576	139	550	3.18
335	7	3633	4.34	415	36,076	141		
331	11	3733	4.39	419	48,137	143		
331	22	3833	4.4	420	48,778	145		
354	0.83	3431	4.11	396	1,456	121	623	0.84
375	1.44	3531	3.88	374	4,291	123	661	1.28
372	1.62	3433	3.91	373	12,627	137	655	1.56
357	3.55	3533	4.07	388	14,045	139	629	3.40
374	7	3633	3.88	371	36,200	141		
372	12	3733	3.91	373	48,245	143		
357	22	3833	4.08	389	48,768	145		
404	0.94	3431	3.6	347	1,809	121	711	0.95
410	1.58	3531	3.55	342	4,205	123	721	1.34
413	14	3733	3.52	336	48,333	143		
417	23	3833	3.5	333	48,748	145		
457	1.07	3431	3.18	307	2,067	121	805	1.06
474	1.60	3531	3.07	296	4,420	123	834	1.45
472	16	3733	3.08	294	48,431	143		
457	20	3833	3.18	304	48,738	145		
513	1.19	3431	2.83	273	2,273	121	904	1.16
524	1.78	3531	2.77	267	4,306	123	923	1.50
505	22	3833	2.88	275	48,727	145		
573	1.29	3431	2.54	245	2,409	121	1008	1.25
596	1.89	3531	2.44	235	4,435	123	1049	1.59
669	1.43	3431	2.17	209	2,574	121	1178	1.38
646	1.95	3531	2.25	217	4,409	123	1138	1.64
739	1.52	3431	1.97	190	2,622	121	1301	1.48
727	2.05	3531	2	193	4,263	123	1280	1.72
838	1.49	3431	1.74	167	2,688	121	1475	1.44
814	2.13	3531	1.79	172	4,126	123	1434	1.79
935	1.76	3431	1.56	150	2,703	121	1646	1.69
909	2.21	3531	1.6	154	3,994	123	1600	1.86
1050	1.73	3431	1.38	134	2,695	121	1849	1.67
996	2.28	3531	1.46	141	3,884	123	1754	1.92
1174	1.62	3431	1.24	119	2,705	121	2068	1.56
1140	2.37	3531	1.28	123	3,728	123	2008	1.99

87Hz\* 400VY triangle-coupled motor supplied by drive

LS, LSES 1500 min <sup>-1</sup> - 50 Hz		Cb - Gearbox					LS, LSES 2600 min <sup>-1</sup> - 87 Hz	
N <sub>S</sub> (min <sup>-1</sup> )	Kp	Cb / MI-MU	i	M (Nm)	F <sub>R</sub> E/2 (N)	Dim. MI < ——— > page	N <sub>S</sub> (min <sup>-1</sup> )	Kp
<b>18.5 kW - 50 Hz</b>		<i>LSES 180 M IFT/IE3 LS 180 MT FFB5 IFT/NIE</i>					<b>32.2 kW - 87 Hz*</b>	
8.86	0.79	3833	164	19119	35,471	145		
10.0	0.90	3833	146	16936	39,061	145		
11.2	1.00	3833	130	15106	41,654	145		
12.7	1.13	3833	115	13392	43,741	145		
14.3	0.85	3733	102	11826	21,249	143		
14.1	1.25	3833	103	12001	45,191	145		
16.2	0.96	3733	89.9	10459	24,471	143		
15.8	1.40	3833	92	10700	46,348	145		
19.0	1.10	3733	76.8	8930	28,075	143		
17.9	1.58	3833	81.5	9483	47,259	145		
21.3	1.19	3733	68.3	7943	30,401	143		
20.3	1.79	3833	71.7	8340	47,962	145		
23.8	1.27	3733	61.2	7123	32,335	143		
23.1	2.03	3833	63.1	7343	48,454	145		
26.3	1.35	3733	55.4	6440	33,944	143		
26.2	2.29	3833	55.7	6477	48,791	145		
29.8	1.45	3733	48.8	5682	35,730	143		
28.8	2.52	3833	50.5	5875	48,975	145		
34.0	0.81	3633	42.8	5028	23,105	141		
33.4	1.39	3833	43.6	5128	49,147	145		
33.7	1.55	3733	43.2	5030	37,268	143		
37.3	0.93	3633	39	4586	24,347	141		
36.3	1.62	3733	40.2	4720	37,999	143		
37.4	1.73	3833	38.9	4573	49,233	145		
42.2	1.04	3633	34.5	4054	25,842	141		
40.5	1.89	3733	36	4226	39,163	143		
42.3	2.28	3833	34.4	4043	49,284	145		
48.3	0.84	3533	30.1	3543	11,234	139	84	0.82
46.9	1.14	3633	31.1	3653	26,971	141		
45.7	2.31	3733	31.8	3744	40,300	143		
47.4	3.13	3833	30.8	3615	49,301	145		
53.8	0.93	3533	27.1	3180	13,526	139	94	0.91
52.6	1.26	3633	27.7	3257	28,084	141		
51.3	2.65	3733	28.4	3339	41,253	143		
53.0	3.62	3833	27.5	3231	49,299	145		
60.5	1.04	3533	24.1	2831	15,730	139	106	1.00
57.2	1.36	3633	25.5	2995	28,820	141		
57.8	2.94	3733	25.2	2960	42,147	143		
59.4	4	3833	24.5	2884	49,283	145		
66.0	1.13	3533	22.1	2593	17,232	139	115	1.07
66.6	1.55	3633	21.9	2569	30,017	141		
64.5	3.23	3733	22.6	2653	42,872	143		
66.4	5	3833	21.9	2577	49,258	145		
76.3	1.23	3533	19.1	2242	19,230	139	133	1.17
72.6	1.68	3633	20	2357	30,616	141		
72.4	3.56	3733	20.1	2365	43,549	143		
74.6	5	3833	19.5	2296	49,225	145		

87Hz\* 400VY triangle-coupled motor supplied by drive

LS, LSES 1500 min <sup>-1</sup> - 50 Hz		Cb - Gearbox					LS, LSES 2600 min <sup>-1</sup> - 87 Hz	
N <sub>S</sub> (min <sup>-1</sup> )	Kp	Cb / MI-MU	i	M (Nm)	F <sub>R</sub> E/2 (N)	Dim. MI < ——— > page	N <sub>S</sub> (min <sup>-1</sup> )	Kp
<b>18.5 kW - 50 Hz</b>		<i>LSES 180 M IFT/IE3 LS 180 MT FFB5 IFT/NIE</i>					<b>32.2 kW - 87 Hz*</b>	
84.5	1.43	3533	17.2	2027	18,985	139	147	1.27
82.1	1.87	3633	17.7	2084	31,382	141		
81.7	3.95	3733	17.8	2096	44,184	143		
83.8	6	3833	17.4	2043	49,188	145		
92.3	0.83	3433	15.8	1855	5,033	137		
96.0	1.57	3533	15.2	1783	18,637	139	168	1.38
96.2	2.14	3633	15.1	1780	32,238	141		
92.8	4.41	3733	15.7	1844	44,779	143		
94.6	6	3833	15.4	1809	49,147	145		
108	0.96	3433	13.5	1587	8,593	137	188	0.86
104	1.65	3533	14	1644	18,390	139	182	1.46
108	2.37	3633	13.5	1583	32,791	141		
105	5	3733	13.8	1623	45,298	143		
106	7	3833	13.7	1611	49,108	145		
119	1.06	3433	12.2	1438	9,900	137	208	0.92
117	1.82	3533	12.4	1461	18,017	139	205	1.58
121	2.61	3633	12.1	1419	33,251	141		
120	5	3733	12.2	1432	45,750	143		
117	7	3833	12.5	1467	49,077	145		
135	1.16	3433	10.8	1268	12,302	137	236	1.00
131	1.95	3533	11.1	1305	17,632	139	229	1.70
133	2.86	3633	10.9	1283	33,633	141		
132	6	3733	11	1299	46,064	143		
132	8	3833	11	1297	49,037	145		
151	1.26	3433	9.67	1137	13,613	137	263	1.07
146	2.15	3533	9.94	1169	17,247	139	256	1.83
151	3.19	3633	9.63	1132	34,058	141		
151	7	3733	9.64	1134	46,453	143		
146	9	3833	9.96	1171	49,005	145		
169	1.35	3433	8.6	1012	14,300	137	295	1.15
161	2.28	3533	9.07	1066	16,915	139	280	1.94
171	3.55	3633	8.53	1002	34,424	141		
169	7	3733	8.62	1013	46,736	143		
166	10	3833	8.75	1029	48,967	145		
189	1.31	3433	7.69	905	14,548	137	330	1.23
184	2.50	3533	7.92	931	16,415	139	321	2.12
191	3.92	3633	7.62	896	34,723	141		
190	8	3733	7.68	902	46,998	143		
180	10	3833	8.11	953	48,946	145		
212	1.16	3433	6.86	807	13,846	137	371	1.11
203	1.65	3533	7.18	844	15,822	139	354	1.58
212	3.69	3633	6.86	807	34,974	141		
211	9	3733	6.9	812	47,212	143		
210	12	3833	6.95	816	48,906	145		
234	1.24	3433	6.21	731	13,589	137	409	1.19
228	1.82	3533	6.38	750	15,400	139	398	1.74
237	4.59	3633	6.15	723	35,208	141		
235	7	3733	6.21	730	47,405	143		
230	13	3833	6.33	744	48,884	145		

87Hz\* 400VY triangle-coupled motor supplied by drive



LS, LSES 1500 min <sup>-1</sup> - 50 Hz		Cb - Gearbox					LS, LSES 2600 min <sup>-1</sup> - 87 Hz	
N <sub>S</sub> (min <sup>-1</sup> )	Kp	Cb / MI-MU	i	M (Nm)	F <sub>R</sub> E/2 (N)	Dim. MI < ——— > page	N <sub>S</sub> (min <sup>-1</sup> )	Kp
<b>18.5 kW - 50 Hz</b>		<i>LSES 180 M IFT/IE3 LS 180 MT FFB5 IFT/NIE</i>					<b>32.2 kW - 87 Hz*</b>	
265	0.86	3531	5.5	653	2,268	123	462	0.83
266	1.21	3433	5.48	644	13,250	137	464	1.16
256	1.95	3533	5.7	670	14,988	139	446	1.86
262	5	3633	5.56	654	35,403	141		
259	7	3733	5.63	662	47,565	143		
263	15	3833	5.55	652	48,855	145		
300	0.97	3531	4.85	576	2,650	123	524	0.91
296	1.43	3433	4.91	578	12,942	137	517	1.36
285	2.56	3533	5.1	600	14,589	139	498	2.44
297	5	3633	4.91	577	35,620	141		
296	8	3733	4.91	578	47,763	143		
291	16	3833	5.01	588	48,835	145		
334	1.08	3531	4.35	517	2,917	123	584	0.98
333	1.41	3433	4.37	514	12,610	137	581	1.35
313	2.69	3533	4.66	547	14,255	139	546	2.56
335	6	3633	4.34	511	35,806	141		
331	9	3733	4.39	516	47,908	143		
331	18	3833	4.4	517	48,811	145		
376	1.17	3531	3.88	460	3,151	123	656	1.03
372	1.31	3433	3.91	460	12,285	137	650	1.25
358	2.88	3533	4.07	478	13,764	139	625	2.74
375	6	3633	3.88	457	35,958	141		
372	10	3733	3.91	460	48,041	143		
357	18	3833	4.08	479	48,799	145		
410	1.28	3531	3.55	422	3,087	123	716	1.08
414	11	3733	3.52	414	48,150	143		
417	18	3833	3.49	410	48,775	145		
458	0.87	3431	3.18	378	660	121	799	0.85
474	1.29	3531	3.07	365	3,456	123	828	1.17
472	13	3733	3.08	362	48,270	143		
458	16	3833	3.18	374	48,763	145		
514	0.96	3431	2.83	337	966	121	897	0.93
525	1.44	3531	2.77	329	3,385	123	916	1.21
506	18	3833	2.88	338	48,750	145		
574	1.04	3431	2.54	302	1,211	121	1001	1.00
596	1.53	3531	2.44	290	3,618	123	1041	1.28
670	1.16	3431	2.17	258	1,494	121	1170	1.11
647	1.58	3531	2.25	267	3,649	123	1130	1.32
740	1.24	3431	1.97	234	1,620	121	1292	1.19
728	1.66	3531	2	238	3,653	123	1271	1.39
839	1.21	3431	1.74	206	1,760	121	1465	1.16
815	1.73	3531	1.79	212	3,654	123	1424	1.44
936	1.42	3431	1.56	185	1,835	121	1634	1.36
910	1.80	3531	1.6	190	3,629	123	1589	1.50
1052	1.41	3431	1.38	164	1,914	121	1836	1.35
998	1.85	3531	1.46	173	3,602	123	1742	1.54
1176	1.31	3431	1.24	147	1,940	121	2053	1.25
1142	1.93	3531	1.28	151	3,541	123	1994	1.61

87Hz\* 400VY triangle-coupled motor supplied by drive

LS, LSES 1500 min <sup>-1</sup> - 50 Hz		Cb - Gearbox					LS, LSES 2600 min <sup>-1</sup> - 87 Hz	
N <sub>S</sub> (min <sup>-1</sup> )	Kp	Cb / MI-MU	i	M (Nm)	F <sub>R</sub> E/2 (N)	Dim. MI < ——— > page	N <sub>S</sub> (min <sup>-1</sup> )	Kp
<b>22 kW - 50 Hz</b>		<i>LSES 180 LUR IFT/IE3 LS 180 LR FCPL 54H1D</i>					<b>38.3 kW - 87 Hz*</b>	
11.2	0.84	3833	130	17968	37,430	145		
12.7	0.95	3833	115	15929	40,534	145		
14.1	1.05	3833	103	14274	42,708	145		
16.2	0.80	3733	89.9	12440	19,800	143		
15.8	1.18	3833	92	12727	44,461	145		
19.0	0.93	3733	76.8	10622	24,087	143		
17.9	1.33	3833	81.5	11279	45,857	145		
21.3	1.00	3733	68.3	9448	26,854	143		
20.3	1.50	3833	71.7	9920	46,951	145		
23.8	1.07	3733	61.2	8472	29,155	143		
23.1	1.70	3833	63.1	8734	47,736	145		
26.3	1.13	3733	55.4	7660	31,068	143		
26.2	1.93	3833	55.7	7704	48,289	145		
29.8	1.22	3733	48.8	6759	33,193	143		
28.8	2.12	3833	50.5	6988	48,603	145		
33.4	1.17	3833	43.6	6100	48,911	145		
33.7	1.31	3733	43.2	5983	35,021	143		
37.3	0.78	3633	39	5455	21,904	141		
36.3	1.36	3733	40.2	5614	35,891	143		
37.4	1.46	3833	38.9	5440	49,083	145		
42.2	0.88	3633	34.5	4822	23,682	141		
40.5	1.59	3733	36	5027	37,275	143		
42.3	1.91	3833	34.4	4809	49,201	145		
46.9	0.96	3633	31.1	4345	25,026	141		
45.7	1.95	3733	31.8	4453	38,629	143		
47.4	2.63	3833	30.8	4299	49,263	145		
53.8	0.78	3533	27.1	3782	9,725	139		
52.6	1.06	3633	27.7	3874	26,349	141		
51.3	2.23	3733	28.4	3972	39,762	143		
53.0	3.04	3833	27.5	3843	49,295	145		
60.5	0.88	3533	24.1	3367	12,345	139		
57.2	1.14	3633	25.5	3563	27,225	141		
57.8	2.47	3733	25.2	3521	40,825	143		
59.4	3.62	3833	24.5	3430	49,302	145		
66.0	0.95	3533	22.1	3085	14,126	139		
66.6	1.31	3633	21.9	3056	28,649	141		
64.5	2.71	3733	22.6	3155	41,687	143		
66.4	4.03	3833	21.9	3066	49,294	145		
76.3	1.04	3533	19.1	2667	16,765	139		
72.6	1.41	3633	20	2803	29,361	141		
72.4	2.99	3733	20.1	2813	42,493	143		
74.6	4	3833	19.5	2731	49,272	145		
84.5	1.20	3533	17.2	2411	17,915	139	148	1.07
82.1	1.57	3633	17.7	2479	30,272	141		
81.7	3.32	3733	17.8	2493	43,248	143		
83.8	5	3833	17.4	2430	49,242	145		

87Hz\* 400VY triangle-coupled motor supplied by drive

LS, LSES 1500 min <sup>-1</sup> - 50 Hz		Cb - Gearbox					LS, LSES 2600 min <sup>-1</sup> - 87 Hz	
N <sub>S</sub> (min <sup>-1</sup> )	Kp	Cb / MI-MU	i	M (Nm)	F <sub>R</sub> E/2 (N)	Dim. MI < ——— > page	N <sub>S</sub> (min <sup>-1</sup> )	Kp
<b>22 kW - 50 Hz</b>		<i>LSES 180 LUR IFT/IE3 LS 180 LR FCPL 54H1D</i>					<b>38.3 kW - 87 Hz*</b>	
96,0	1,32	3533	15,2	2121	17 695	139	168	1,16
96,2	1,80	3633	15,1	2117	31 291	141		
92,8	3,71	3733	15,7	2193	43 956	143		
94,6	5	3833	15,4	2152	49 205	145		
108	0,81	3433 MU	13,5	1888	4 570	137		
104	1,39	3533	14	1955	17 525	139	182	1,23
108	2,00	3633	13,5	1883	31 948	141		
105	4,14	3733	13,8	1931	44 574	143		
106	6	3833	13,7	1916	49 167	145		
119	0,89	3433	12,2	1710	7 003	137		
117	1,53	3533	12,4	1738	17 245	139	205	1,33
121	2,20	3633	12,1	1688	32 495	141		
120	4,62	3733	12,2	1703	45 111	143		
117	6	3833	12,5	1745	49 135	145		
135	0,98	3433	10,8	1508	9 575	137	236	0,84
131	1,64	3533	11,1	1552	16 944	139	229	1,43
133	2,40	3633	10,9	1526	32 950	141		
132	5	3733	11	1545	45 484	143		
132	7	3833	11	1543	49 094	145		
151	1,06	3433	9,67	1352	11 394	137	263	0,9
146	1,81	3533	9,94	1390	16 630	139	256	1,54
151	2,68	3633	9,63	1347	33 455	141		
151	6	3733	9,64	1348	45 947	143		
146	7	3833	9,96	1393	49 060	145		
169	1,14	3433	8,6	1203	12 964	137	296	0,97
161	1,92	3533	9,07	1268	16 352	139	281	1,64
171	2,99	3633	8,53	1192	33 890	141		
169	6	3733	8,62	1205	46 284	143		
166	8	3833	8,75	1224	49 019	145		
189	1,10	3433	7,69	1076	13 968	137	331	1,03
184	2,10	3533	7,92	1108	15 922	139	321	1,79
191	3,30	3633	7,62	1066	34 246	141		
190	7	3733	7,68	1073	46 595	143		
180	8	3833	8,11	1134	48 995	145		
212	0,98	3433	6,86	959	13 260	137		
203	1,39	3533	7,18	1004	15 335	139	355	1,33
212	3,10	3633	6,86	959	34 544	141		
211	8	3733	6,9	965	46 849	143		
210	10	3833	6,95	971	48 951	145		
234	1,04	3433	6,21	869	13 057	137	410	1,00
228	1,53	3533	6,38	892	14 968	139	399	1,47
237	3,85	3633	6,15	860	34 823	141		
235	5	3733	6,21	868	47 079	143		
230	11	3833	6,33	885	48 926	145		

87Hz\* 400VY triangle-coupled motor supplied by drive

LS, LSES 1500 min <sup>-1</sup> - 50 Hz		Cb - Gearbox					LS, LSES 2600 min <sup>-1</sup> - 87 Hz	
N <sub>S</sub> (min <sup>-1</sup> )	Kp	Cb / MI-MU	i	M (Nm)	F <sub>R</sub> E/2 (N)	Dim. MI < — > page	N <sub>S</sub> (min <sup>-1</sup> )	Kp
<b>22 kW - 50 Hz</b>		<i>LSES 180 LUR IFT/IE3 LS 180 LR FCPL 54H1D</i>					<b>38.3 kW - 87 Hz*</b>	
266	1.02	3433	5.48	766	12,780	137	465	0.98
256	1.64	3533	5.7	797	14,601	139	447	1.57
262	4.17	3633	5.56	778	35,055	141		
259	6	3733	5.63	787	47,269	143		
263	12	3833	5.55	775	48,894	145		
300	0.81	3531	4.85	685	1,270	123		
296	1.2	3433	4.91	687	12,522	137	518	1.15
285	2.15	3533	5.1	714	14,242	139	499	2.05
297	4.57	3633	4.91	686	35,312	141		
296	7	3733	4.91	687	47,505	143		
291	13	3833	5.01	700	48,870	145		
334	0.91	3531	4.35	615	1,652	123		
333	1.18	3433	4.37	611	12,237	137	582	1.13
313	2.26	3533	4.66	651	13,938	139	547	2.16
335	5	3633	4.34	608	35,534	141		
331	8	3733	4.39	614	47,677	143		
331	15	3833	4.4	615	48,844	145		
376	0.98	3531	3.88	547	2,003	123		
372	1.10	3433	3.91	547	11,950	137	651	1.06
358	2.42	3533	4.07	569	13,487	139	626	2.31
375	5	3633	3.88	543	35,715	141		
372	9	3733	3.91	547	47,836	143		
357	15	3833	4.08	570	48,829	145		
410	1.08	3531	3.55	501	1,988	123		
414	9	3733	3.52	492	47,965	143		
417	16	3833	3.49	488	48,802	145		
474	1.09	3531	3.07	434	2,496	123		
472	11	3733	3.08	431	48,109	143		
458	13	3833	3.18	445	48,787	145		
514	0.81	3431 MU	2.83	400	15	121		
525	1.21	3531	2.77	392	2,453	123	918	1.02
506	15	3833	2.88	402	48,773	145		
574	0.88	3431 MU	2.54	359	15	121		
596	1.29	3531	2.44	345	2,804	123	1043	1.08
670	0.98	3431 MU	2.17	307	418	121		
647	1.33	3531	2.25	318	2,876	123	1132	1.11
740	1.04	3431	1.97	278	622	121	1294	1.00
728	1.40	3531	2	283	2,944	123	1273	1.17
839	1.02	3431	1.74	245	835	121	1467	0.98
815	1.45	3531	1.79	252	3,000	123	1426	1.22
936	1.20	3431	1.56	220	970	121	1637	1.15
910	1.51	3531	1.6	226	3,015	123	1591	1.26
1052	1.18	3431	1.38	196	1,085	121	1839	1.13
998	1.56	3531	1.46	206	3,019	123	1744	1.30
1176	1.10	3431	1.24	175	1,179	121	2056	1.06
1142	1.62	3531	1.28	180	2,998	123	1997	1.35

87Hz\* 400VY triangle-coupled motor supplied by drive

Selection tables

Compabloc: Cb / LS, LSES motors / 4 poles

LS, LSES 1500 min <sup>-1</sup> - 50 Hz		Cb - Gearbox					LS, LSES 2600 min <sup>-1</sup> - 87 Hz	
N <sub>S</sub> (min <sup>-1</sup> )	Kp	Cb / MI-MU	i	M (Nm)	F <sub>R</sub> E/2 (N)	Dim. MI < ——— > page	N <sub>S</sub> (min <sup>-1</sup> )	Kp
<b>30 kW - 50 Hz</b>		<i>LSES 200 LU IFT/IE3 LS 200 LT FCPL 54H1D + CDF7</i>					<b>52.2 kW - 87 Hz*</b>	
15.9	0.87	3833	92	17313	38,479	145		
17.9	0.98	3833	81.5	15343	41,340	145		
20.4	1.11	3833	71.7	13494	43,626	145		
23.8	0.79	3733	61.2	11524	21,960	143		
23.1	1.25	3833	63.1	11882	45,305	145		
26.4	0.83	3733	55.4	10421	24,562	143		
26.2	1.42	3833	55.7	10480	46,526	145		
29.9	0.89	3733	48.8	9194	27,453	143		
28.9	1.56	3833	50.5	9505	47,244	145		
33.8	0.96	3733	43.2	8139	29,940	143		
33.1	1.78	3833	44.1	8297	47,985	145		
37.8	1.03	3733	38.7	7275	31,977	143		
37.1	1.98	3833	39.4	7416	48,422	145		
40.3	1.05	3733	36.3	6827	33,032	143		
41.6	2.22	3833	35.1	6605	48,747	145		
45.6	1.13	3733	32	6022	34,931	143		
47.5	1.93	3833	30.8	5848	48,982	145		
51.4	1.64	3733	28.4	5403	36,389	143		
53.1	2.24	3833	27.5	5227	49,128	145		
58.0	1.81	3733	25.2	4790	37,835	143		
59.5	2.66	3833	24.5	4665	49,221	145		
66.8	0.96	3633	21.9	4157	25,553	141		
64.7	1.99	3733	22.6	4292	39,008	143		
66.6	2.96	3833	21.9	4170	49,275	145		
72.8	1.04	3633	20	3813	26,521	141		
72.6	2.20	3733	20.1	3827	40,104	143		
74.8	3.11	3833	19.5	3715	49,299	145		
84.7	0.89	3533	17.2	3279	12,901	139	148	0.78
82.4	1.15	3633	17.7	3372	27,761	141		
81.9	2.44	3733	17.8	3391	41,131	143		
84.0	3.57	3833	17.4	3306	49,301	145		
96.2	0.97	3533	15.2	2885	15,388	139	168	0.85
96.5	1.32	3633	15.1	2879	29,147	141		
93.1	2.73	3733	15.7	2983	42,094	143		
94.9	3.79	3833	15.4	2927	49,286	145		
104	1.02	3533	14	2659	15,542	139	183	0.90
108	1.47	3633	13.5	2561	30,041	141		
106	3.04	3733	13.8	2626	42,934	143		
107	4	3833	13.7	2606	49,261	145		
117	1.13	3533	12.4	2364	15,480	139	206	0.98
121	1.61	3633	12.1	2296	30,785	141		
120	3.39	3733	12.2	2316	43,664	143		
117	4	3833	12.5	2373	49,235	145		
132	1.20	3533	11.1	2111	15,368	139	230	1.05
134	1.76	3633	10.9	2076	31,404	141		
132	3.69	3733	11	2101	44,172	143		
132	5	3833	11	2099	49,197	145		

87Hz\* 400VY triangle-coupled motor supplied by drive

LS, LSES 1500 min <sup>-1</sup> - 50 Hz		Cb - Gearbox					LS, LSES 2600 min <sup>-1</sup> - 87 Hz	
N <sub>S</sub> (min <sup>-1</sup> )	Kp	Cb / MI-MU	i	M (Nm)	F <sub>R</sub> E/2 (N)	Dim. MI < — > page	N <sub>S</sub> (min <sup>-1</sup> )	Kp
<b>30 kW - 50 Hz</b>		<i>LSES 200 LU IFT/IE3 LS 200 LT FCPL 54H1D + CDF7</i>					<b>52.2 kW - 87 Hz*</b>	
147	1.33	3533	9.94	1891	15,217	139	257	1.13
152	1.97	3633	9.63	1832	32,091	141		
151	4.16	3733	9.64	1834	44,802	143		
147	5	3833	9.96	1895	49,163	145		
161	1.41	3533	9.07	1725	15,060	139	282	1.20
171	2.19	3633	8.53	1622	32,682	141		
169	4.58	3733	8.62	1639	45,260	143		
167	6	3833	8.75	1665	49,119	145		
184	1.54	3533	7.92	1507	14,793	139	323	1.31
192	2.42	3633	7.62	1450	33,166	141		
189	5	3833	7.73	1471	49,078	145		
190	5	3733	7.68	1460	45,683	143		
203	1.02	3533	7.18	1365	14,219	139	356	0.98
204	2.56	3633	7.15	1360	33,417	141		
207	3.58	3733	7.04	1338	45,970	143		
212	8	3833	6.88	1309	49,040	145		
229	1.13	3533	6.38	1214	13,970	139	401	1.08
237	2.83	3633	6.15	1170	33,952	141		
235	4	3733	6.21	1180	46,342	143		
233	8	3833	6.27	1192	49,011	145		
256	1.20	3533	5.7	1084	13,712	139	449	1.15
262	3.06	3633	5.56	1058	34,267	141		
259	4	3733	5.63	1071	46,601	143		
263	9	3833	5.55	1055	48,974	145		
286	1.58	3533	5.1	971	13,445	139	501	1.51
297	3.36	3633	4.91	934	34,617	141		
297	5	3733	4.91	935	46,922	143		
292	10	3833	5.01	952	48,946	145		
314	1.66	3533	4.66	886	13,208	139	549	1.59
336	3.68	3633	4.34	826	34,918	141		
332	6	3733	4.39	835	47,156	143		
332	11	3833	4.4	836	48,912	145		
359	1.78	3533	4.07	774	12,849	139	628	1.70
376	3.70	3633	3.88	739	35,165	141		
373	6	3733	3.91	744	47,371	143		
401	3.48	3633	3.64	693	35,293	141		
454	3.43	3633	3.21	611	35,523	141		
526	0.89	3531	2.77	533	359	123		
598	0.95	3531	2.44	469	962	123	1047	0.79
649	0.98	3531	2.25	432	1,139	123	1136	0.82
730	1.02	3531	2	384	1,347	123	1278	0.86
818	1.07	3531	1.79	343	1,503	123	1431	0.89
913	1.11	3531	1.6	307	1,627	123	1598	0.93
1000	1.14	3531	1.46	280	1,704	123	1751	0.96
1145	1.19	3531	1.28	245	1,775	123	2005	0.99

87Hz\* 400VY triangle-coupled motor supplied by drive

LS, LSES 1500 min <sup>-1</sup> - 50 Hz		Cb - Gearbox					LS, LSES 2600 min <sup>-1</sup> - 87 Hz	
N <sub>S</sub> (min <sup>-1</sup> )	Kp	Cb / MI-MU	i	M (Nm)	F <sub>R</sub> E/2 (N)	Dim. MI < ——— > page	N <sub>S</sub> (min <sup>-1</sup> )	Kp
<b>37 kW - 50 Hz</b>		<i>LSES 225 SR IFT/IE3 LS 225 ST FCPL 54H1D + CDF7</i>					<b>64.4 kW - 87 Hz</b>	
18.0	0.80	3833	81.5	18822	35,990	145		
20.5	0.90	3833	71.7	16554	39,632	145		
23.3	1.02	3833	63.1	14576	42,335	145		
26.4	1.15	3833	55.7	12856	44,325	145		
29.1	1.27	3833	50.5	11661	45,512	145		
34.0	0.78	3733	43.2	9985	25,589	143		
33.3	1.45	3833	44.1	10178	46,759	145		
38.0	0.84	3733	38.7	8925	28,088	143		
37.3	1.62	3833	39.4	9098	47,512	145		
40.5	0.86	3733	36.3	8375	29,382	143		
41.8	1.81	3833	35.1	8103	48,089	145		
45.9	0.92	3733	32	7387	31,712	143		
46.5	2.01	3833	31.6	7288	48,478	145		
53.1	2.28	3833	27.7	6387	48,821	145		
59.8	2.17	3833	24.5	5723	49,015	145		
65.1	1.62	3733	22.6	5265	36,713	143		
67.0	2.41	3833	21.9	5116	49,149	145		
73.0	1.79	3733	20.1	4695	38,058	143		
75.2	2.53	3833	19.5	4557	49,235	145		
82.8	0.94	3633	17.7	4137	25,610	141		
82.3	1.99	3733	17.8	4161	39,318	143		
84.5	2.90	3833	17.4	4055	49,283	145		
97.0	1.08	3633	15.1	3532	27,311	141		
93.6	2.22	3733	15.7	3659	40,499	143		
95.4	3.09	3833	15.4	3591	49,302	145		
109	1.20	3633	13.5	3142	28,408	141		
106	2.48	3733	13.8	3222	41,530	143		
107	3.46	3833	13.7	3197	49,298	145		
122	1.32	3633	12.1	2817	29,321	141		
121	2.76	3733	12.2	2842	42,426	143		
118	3.61	3833	12.5	2911	49,285	145		
134	1.44	3633	10.9	2547	30,080	141		
133	3.01	3733	11	2578	43,049	143		
133	4	3833	11	2575	49,258	145		
152	1.61	3633	9.63	2247	30,923	141		
152	3.39	3733	9.64	2250	43,821	143		
147	4	3833	9.96	2324	49,229	145		
172	1.79	3633	8.53	1989	31,648	141		
170	3.73	3733	8.62	2011	44,384	143		
168	5	3833	8.75	2042	49,188	145		
193	1.97	3633	7.62	1778	32,242	141		
191	4.13	3733	7.68	1791	44,903	143		
181	5	3833	8.11	1892	49,163	145		
205	2.09	3633	7.15	1669	32,550	141		
213	4.54	3733	6.9	1611	45,327	143		
211	6	3833	6.95	1620	49,110	145		

LS, LSES 1500 min <sup>-1</sup> - 50 Hz		Cb - Gearbox					LS, LSES 2600 min <sup>-1</sup> - 87 Hz	
N <sub>S</sub> (min <sup>-1</sup> )	Kp	Cb / MI-MU	i	M (Nm)	F <sub>R</sub> E/2 (N)	Dim. MI < — > page	N <sub>S</sub> (min <sup>-1</sup> )	Kp
<b>37 kW - 50 Hz</b>		<i>LSES 225 SR IFT/E3 LS 225 ST FCPL 54H1D + CDF7</i>					<b>64.4 kW - 87 Hz</b>	
239	2.30	3633	6.15	1436	33,206	141		
237	3.29	3733	6.21	1448	45,711	143		
232	6	3833	6.33	1477	49,079	145		
264	2.49	3633	5.56	1298	33,592	141		
261	3.61	3733	5.63	1313	46,029	143		
265	7	3833	5.55	1294	49,036	145		
299	2.74	3633	4.91	1145	34,022	141		
299	4	3733	4.91	1146	46,422	143		
293	8	3833	5.01	1168	49,004	145		
338	3	3633	4.34	1014	34,391	141		
334	5	3733	4.39	1025	46,709	143		
334	9	3833	4.4	1026	48,966	145		
378	3.02	3633	3.88	906	34,694	141		
375	5	3733	3.91	913	46,973	143		
360	9	3833	4.08	951	48,945	145		
403	2.83	3633	3.64	850	34,851	141		
417	6	3733	3.52	821	47,190	143		
421	9	3833	3.49	814	48,905	145		
457	2.80	3633	3.21	750	35,133	141		
476	6	3733	3.08	719	47,429	143		
461	8	3833	3.18	742	48,884	145		
510	9	3833	2.88	671	48,862	145		



LS, LSES 1500 min <sup>-1</sup> - 50 Hz		Cb - Gearbox					LS, LSES 2600 min <sup>-1</sup> - 87 Hz	
N <sub>S</sub> (min <sup>-1</sup> )	Kp	Cb / MI-MU	i	M (Nm)	F <sub>R</sub> E/2 (N)	Dim. MI < ——— > page	N <sub>S</sub> (min <sup>-1</sup> )	Kp
<b>45 kW - 50 Hz</b>		<i>LSES 225 MG IFT/IE3 LS 225 MR FCPL 54H1D + CDF7</i>					<b>78.3 kW - 87 Hz</b>	
23.3	0.84	3833	63.1	17730	37,817	145		
26.4	0.95	3833	55.7	15638	40,939	145		
29.1	1.04	3833	50.5	14184	42,818	145		
33.3	1.19	3833	44.1	12380	44,817	145		
37.3	1.33	3833	39.4	11067	46,041	145		
41.8	1.49	3833	35.1	9856	46,998	145		
46.5	1.65	3833	31.6	8865	47,657	145		
53.1	1.87	3833	27.7	7769	48,258	145		
59.8	1.78	3833	24.5	6962	48,613	145		
65.1	1.33	3733	22.6	6405	34,028	143		
67.0	1.98	3833	21.9	6223	48,874	145		
73.0	1.47	3733	20.1	5711	35,664	143		
75.2	2.08	3833	19.5	5543	49,059	145		
82.3	1.63	3733	17.8	5061	37,196	143		
84.5	2.39	3833	17.4	4933	49,181	145		
97.0	0.89	3633	15.1	4296	25,162	141		
93.6	1.83	3733	15.7	4451	38,633	143		
95.4	2.54	3833	15.4	4368	49,257	145		
109	0.98	3633	13.5	3821	26,497	141		
106	2.04	3733	13.8	3919	39,887	143		
107	2.85	3833	13.7	3888	49,293	145		
122	1.08	3633	12.1	3427	27,607	141		
121	2.27	3733	12.2	3457	40,977	143		
118	2.97	3833	12.5	3541	49,302	145		
134	1.18	3633	10.9	3098	28,530	141		
133	2.47	3733	11	3135	41,734	143		
133	3.35	3833	11	3132	49,296	145		
152	1.32	3633	9.63	2734	29,555	141		
152	2.78	3733	9.64	2737	42,674	143		
147	3.62	3833	9.96	2827	49,280	145		
172	1.47	3633	8.53	2420	30,438	141		
170	3.07	3733	8.62	2446	43,358	143		
168	3.98	3833	8.75	2484	49,248	145		
193	1.62	3633	7.62	2163	31,160	141		
191	3.40	3733	7.68	2179	43,990	143		
181	4	3833	8.11	2302	49,226	145		
205	1.72	3633	7.15	2030	31,534	141		
213	3.73	3733	6.9	1960	44,506	143		
211	5	3833	6.95	1971	49,176	145		
239	1.89	3633	6.15	1746	32,332	141		
237	2.70	3733	6.21	1761	44,973	143		
232	5	3833	6.33	1797	49,145	145		
264	2.05	3633	5.56	1579	32,803	141		
261	2.97	3733	5.63	1598	45,359	143		
265	6	3833	5.55	1574	49,100	145		

LS, LSES 1500 min <sup>-1</sup> - 50 Hz		Cb - Gearbox					LS, LSES 2600 min <sup>-1</sup> - 87 Hz	
N <sub>S</sub> (min <sup>-1</sup> )	Kp	Cb / MI-MU	i	M (Nm)	F <sub>R</sub> E/2 (N)	Dim. MI < — > page	N <sub>S</sub> (min <sup>-1</sup> )	Kp
<b>45 kW - 50 Hz</b>		<i>LSES 225 MG IFT/E3 LS 225 MR FCPL 54H1D + CDF7</i>					<b>78.3 kW - 87 Hz</b>	
299	2.25	3633	4.91	1393	33,325	141		
299	3.37	3733	4.91	1395	45,838	143		
293	7	3833	5.01	1421	49,066	145		
338	2.46	3633	4.34	1233	33,775	141		
334	3.75	3733	4.39	1247	46,186	143		
334	7	3833	4.4	1248	49,025	145		
378	2.48	3633	3.88	1102	34,143	141		
375	4.18	3733	3.91	1110	46,508	143		
360	7	3833	4.08	1157	49,001	145		
403	2.33	3633	3.64	1034	34,334	141		
417	4.62	3733	3.52	999	46,771	143		
421	8	3833	3.49	990	48,956	145		
457	2.30	3633	3.21	912	34,677	141		
476	5	3733	3.08	875	47,062	143		
461	7	3833	3.18	903	48,932	145		
510	7	3833	2.88	817	48,906	145		

LS, LSES 1500 min <sup>-1</sup> - 50 Hz		Cb - Gearbox					LS, LSES 2600 min <sup>-1</sup> - 87 Hz	
N <sub>S</sub> (min <sup>-1</sup> )	K <sub>p</sub>	Cb / MI-MU	i	M (Nm)	F <sub>R</sub> E/2 (N)	Dim. MI-MU* < — > page	N <sub>S</sub> (min <sup>-1</sup> )	K <sub>p</sub>
<b>55 kW - 50 Hz</b>		<i>LSES 250 ME IFT/IE3 MU - LS 250 ME FCPL 60H2D</i>					<b>95.7 kW - 87 Hz</b>	
29.3	0.86	3833	50.5	17220	38,623	145+148		
33.5	0.98	3833	44.1	15031	41,753	145+148		
37.5	1.09	3833	39.4	13436	43,691	145+148		
42.1	1.22	3833	35.1	11966	45,225	145+148		
46.8	1.36	3833	31.6	10763	46,297	145+148		
53.4	1.54	3833	27.7	9432	47,294	145+148		
60.3	1.46	3833 MU	24.5	8452	47,899	145+148		
65.5	1.10	3733 MU	22.6	7776	30,796	143+148		
67.4	1.63	3833 MU	21.9	7555	48,359	145+148		
73.5	1.21	3733 MU	20.1	6933	32,782	143+148		
75.7	1.71	3833	19.5	6730	48,701	145+148		
82.9	1.34	3733 MU	17.8	6144	34,642	143+148		
85.0	1.96	3833	17.4	5989	48,943	145+148		
94.2	1.50	3733 MU	15.7	5404	36,387	143+148		
96.0	2.08	3833	15.4	5303	49,112	145+148		
110	0.81	3633 MU	13.5	4639	24,197	141+148		
107	1.68	3733 MU	13.8	4758	37,909	143+148		
108	2.34	3833	13.7	4721	49,214	145+148		
122	0.89	3633 MU	12.1	4160	25,545	141+148		
121	1.87	3733 MU	12.2	4197	39,233	143+148		
118	2.44	3833	12.5	4299	49,263	145+148		
135	0.97	3633 MU	10.9	3762	26,665	141+148		
134	2.03	3733	11	3806	40,152	143+148		
134	2.75	3833	11	3803	49,296	145+148		
153	1.09	3633 MU	9.63	3319	27,910	141+148		
153	2.29	3733	9.64	3322	41,293	143+148		
148	2.97	3833	9.96	3433	49,303	145+148		
173	1.21	3633 MU	8.53	2938	28,981	141+148		
171	2.53	3733	8.62	2970	42,124	143+148		
169	3.27	3833	8.75	3016	49,291	145+148		
194	1.34	3633 MU	7.62	2626	29,858	141+148		
193	2.80	3733	7.68	2645	42,890	143+148		
182	3.36	3833	8.11	2795	49,277	145+148		
207	1.41	3633 MU	7.15	2464	30,313	141+148		
214	3.07	3733	6.9	2379	43,517	143+148		
213	3.96	3833	6.95	2393	49,238	145+148		
240	1.56	3633 MU	6.15	2120	31,281	141+148		
244	3.45	3733	6.05	2085	44,211	143+148		
233	4	3833	6.33	2182	49,209	145+148		
266	1.68	3633 MU	5.56	1917	31,852	141+148		
263	2.44	3733	5.63	1940	44,553	143+148		
267	5	3833	5.55	1911	49,166	145+148		
301	1.85	3633 MU	4.91	1691	32,487	141+148		
301	2.78	3733	4.91	1693	45,134	143+148		
295	5	3833	5.01	1725	49,131	145+148		

\* 1<sup>st</sup> page for gearbox MI, 2<sup>nd</sup> page for motor B35 + MU

LS, LSES 1500 min <sup>-1</sup> - 50 Hz		Cb - Gearbox					LS, LSES 2600 min <sup>-1</sup> - 87 Hz	
N <sub>S</sub> (min <sup>-1</sup> )	Kp	Cb / MI-MU	i	M (Nm)	F <sub>R</sub> E/2 (N)	Dim. MI-MU* < — > page	N <sub>S</sub> (min <sup>-1</sup> )	Kp
<b>55 kW - 50 Hz</b>		<i>LSES 250 ME IFT/E3 MU - LS 250 ME FCPL 60H2D</i>					<b>95.7 kW - 87 Hz</b>	
340	2.03	3633 MU	4.34	1497	33,032	141+148		
336	3.09	3733	4.39	1513	45,557	143+148		
336	6	3833	4.4	1515	49,088	145+148		
381	2.04	3633 MU	3.88	1338	33,479	141+148		
378	3.44	3733	3.91	1348	45,948	143+148		
363	6	3833	4.08	1404	49,062	145+148		
406	1.92	3633 MU	3.64	1256	33,711	141+148		
420	3.80	3733	3.52	1212	46,267	143+148		
424	6	3833	3.49	1202	49,013	145+148		
460	1.89	3633 MU	3.21	1108	34,128	141+148		
479	4	3733	3.08	1062	46,621	143+148		
465	5	3833	3.18	1096	48,985	145+148		
514	6	3833	2.88	992	48,957	145+148		

\* 1<sup>st</sup> page for gearbox MI, 2<sup>nd</sup> page for motor B35 + MU

LS, LSES 1500 min <sup>-1</sup> - 50 Hz		Cb - Gearbox					LS, LSES 2600 min <sup>-1</sup> - 87 Hz	
N <sub>S</sub> (min <sup>-1</sup> )	Kp	Cb / MI-MU	i	M (Nm)	F <sub>R</sub> E/2 (N)	Dim. MI-MU* < — > page	N <sub>S</sub> (min <sup>-1</sup> )	Kp
<b>75 kW - 50 Hz</b>		<i>LSES 280 SD IFT/E3 MU - LS 280 SC FCPL 60H2D</i>					<b>130 kW - 87 Hz</b>	
37.5	0.80	3833	39.4	18324	36,840	145+148		
42.1	0.90	3833	35.1	16319	39,977	145+148		
46.8	1.00	3833	31.6	14678	42,206	145+148		
53.4	1.13	3833	27.7	12863	44,318	145+148		
75.7	1.25	3833	19.5	9178	47,461	145+148		
85.0	1.44	3833	17.4	8167	48,055	145+148		
96.0	1.53	3833	15.4	7232	48,502	145+148		
108	1.71	3833	13.7	6438	48,804	145+148		
118	1.79	3833	12.5	5864	48,978	145+148		
134	1.49	3733	11	5191	36,888	143+148		
134	2.02	3833	11	5186	49,136	145+148		
153	1.68	3733	9.64	4531	38,444	143+148		
148	2.18	3833	9.96	4681	49,219	145+148		
171	1.85	3733	8.62	4050	39,577	143+148		
169	2.40	3833	8.75	4113	49,279	145+148		
193	2.05	3733	7.68	3607	40,622	143+148		
182	2.47	3833	8.11	3811	49,296	145+148		
214	2.25	3733	6.9	3244	41,477	143+148		
213	2.90	3833	6.95	3264	49,300	145+148		
244	2.53	3733	6.05	2843	42,423	143+148		
233	3.11	3833	6.33	2975	49,289	145+148		
263	1.79	3733	5.63	2645	42,889	143+148		
267	3.66	3833	5.55	2606	49,261	145+148		
301	2.04	3733	4.91	2309	43,682	143+148		
295	3.97	3833	5.01	2352	49,232	145+148		
336	2.26	3733	4.39	2064	44,260	143+148		
336	4.41	3833	4.4	2067	49,192	145+148		
378	2.53	3733	3.91	1838	44,792	143+148		
363	4.43	3833	4.08	1915	49,167	145+148		
420	2.79	3733	3.52	1653	45,228	143+148		
424	4.61	3833	3.49	1640	49,114	145+148		
479	3.16	3733	3.08	1449	45,710	143+148		
465	3.97	3833	3.18	1495	49,083	145+148		
514	4.51	3833	2.88	1352	49,050	145+148		

\* 1<sup>st</sup> page for gearbox MI, 2<sup>nd</sup> page for motor B35 + MU

LS, LSES 1500 min <sup>-1</sup> - 50 Hz		Cb - Gearbox					LS, LSES 2600 min <sup>-1</sup> - 87 Hz	
N <sub>S</sub> (min <sup>-1</sup> )	Kp	Cb / MI-MU	i	M (Nm)	F <sub>R</sub> E/2 (N)	Dim. MI-MU* < ——— > page	N <sub>S</sub> (min <sup>-1</sup> )	Kp
<b>90 kW - 50 Hz</b>		<i>LSES 280 MD IFT/IE3 MU - LS 280 MD FCPL 60H2D + CDF7</i>					<b>157 kW - 87 Hz</b>	
46,8	0,83	3833	31,6	17615	38 002	145+148		
53,4	0,94	3833	27,7	15436	41 214	145+148		
75,7	1,04	3833	19,5	11014	46 087	145+148		
85,0	1,20	3833	17,4	9801	47 037	145+148		
96,0	1,27	3833	15,4	8679	47 769	145+148		
108	1,43	3833	13,7	7726	48 278	145+148		
118	1,49	3833	12,5	7037	48 583	145+148		
134	1,25	3733	11	6205	39 628	143+148		
134	1,68	3833	11	6224	48 873	145+148		
154	1,40	3733	9,64	5416	39 763	143+148		
148	1,82	3833	9,96	5618	49 041	145+148		
172	1,55	3733	8,62	4841	39 803	143+148		
169	2,00	3833	8,75	4936	49 181	145+148		
193	1,71	3733	7,68	4311	39 843	143+148		
182	2,06	3833	8,11	4574	49 233	145+148		
215	1,88	3733	6,9	3878	39 887	143+148		
213	2,42	3833	6,95	3916	49 291	145+148		
245	2,11	3733	6,05	3398	41 110	143+148		
233	2,59	3833	6,33	3571	49 302	145+148		
264	1,5	3733	5,63	3162	44 536	143+148		
267	3,05	3833	5,55	3127	49 296	145+148		
302	1,7	3733	4,91	2760	44 519	143+148		
295	3,31	3833	5,01	2823	49 279	145+148		
338	1,89	3733	4,39	2467	44 488	143+148		
336	3,67	3833	4,4	2480	49 248	145+148		
379	2,11	3733	3,91	2197	44 465	143+148		
363	3,70	3833	4,08	2298	49 226	145+148		
422	2,33	3733	3,52	1976	44 417	143+148		
424	3,84	3833	3,49	1968	49 176	145+148		
481	2,64	3733	3,08	1732	45 000	143+148		
465	3,31	3833	3,18	1794	49 145	145+148		
514	3,76	3833	2,88	1623	49 111	145+148		

\* 1<sup>st</sup> page for gearbox MI, 2<sup>nd</sup> page for motor B35 + MU

# Geared Motors 3000 Range - IMfinity®

## Compabloc

### Selection tables

### Compabloc: Cb / LS, LSES motors / 4 poles

LS, LSES 1500 min <sup>-1</sup> - 50 Hz		Cb - Gearbox					LS, LSES 2600 min <sup>-1</sup> - 87 Hz	
N <sub>S</sub> (min <sup>-1</sup> )	Kp	Cb / MU	i	M (Nm)	F <sub>R</sub> E/2 (N)	Dim. MU* < ——— > page	N <sub>S</sub> (min <sup>-1</sup> )	Kp
<b>110 kW - 50 Hz</b>		<i>LSES 315 SP IFT/IE3 LS 315 SN FCPL 60H2D + CDF7</i>					<b>191 kW - 87 Hz</b>	
53.8	0.78	3833	27.7	18740	36133	145+148		
76.2	0.86	3833	19.5	13372	43764	145+148		
85.6	0.98	3833	17.4	11899	45288	145+148		
96.7	1.05	3833	15.4	10536	46481	145+148		
109	1.17	3833	13.7	9380	47328	145+148		
119	1.23	3833	12.5	8543	47848	145+148		
135	1.38	3833	11	7556	48358	145+148		
149	1.49	3833	9.96	6821	48667	145+148		
170	1.64	3833	8.75	5993	48942	145+148		
183	1.69	3833	8.11	5553	49057	145+148		
214	1.99	3833	6.95	4755	49209	145+148		
235	2.13	3833	6.33	4335	49260	145+148		
268	2.51	3833	5.55	3797	49296	145+148		
297	2.72	3833	5.01	3427	49302	145+148		
338	3.02	3833	4.4	3011	49291	145+148		
365	3.04	3833	4.08	2790	49277	145+148		
426	3.16	3833	3.49	2389	49237	145+148		
468	2.72	3833	3.18	2178	49209	145+148		
517	3.10	3833	2.88	1970	49176	145+148		

\* 1<sup>st</sup> page for gearbox only, 2<sup>nd</sup> page for motor B35 + MU

Dimensions in millimetres

**Tapped form BT**



Cb: 2.3 kg + Motor

1. for self-threading screw

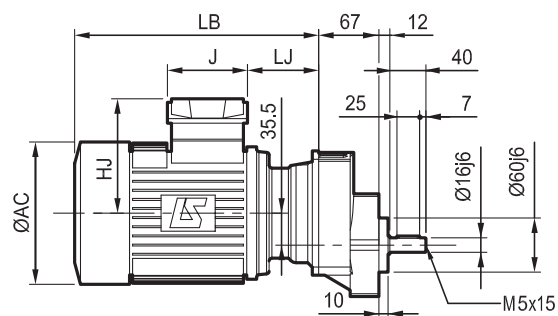
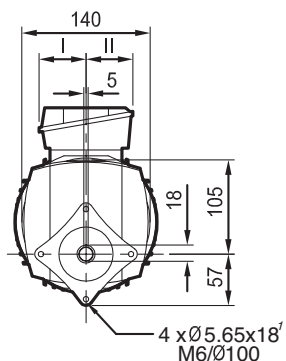

**Flange BD1**



Cb: 2.5 kg + Motor

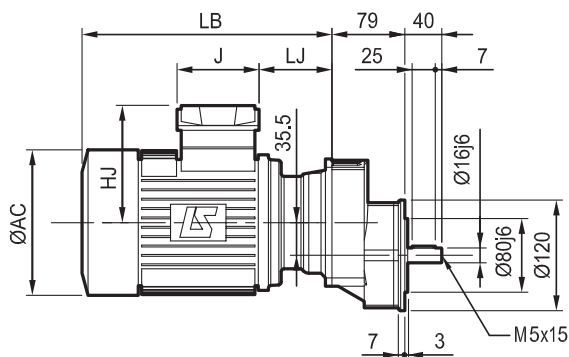
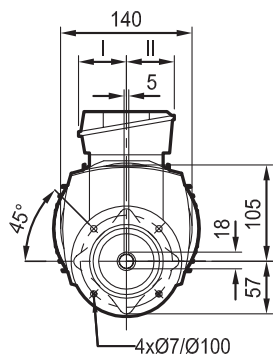

**Flange BD2**



Cb: 2.5 kg + Motor

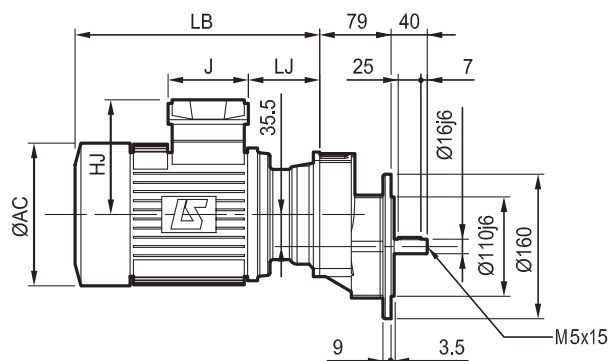
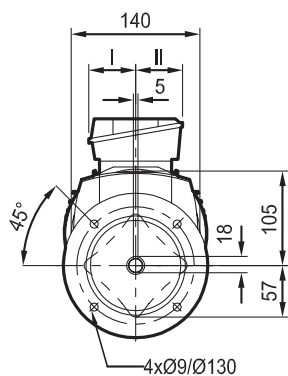

**Flange BD3**



Cb: 2.4 kg + Motor

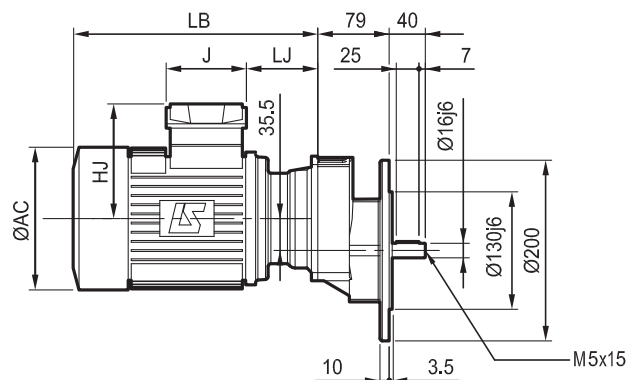
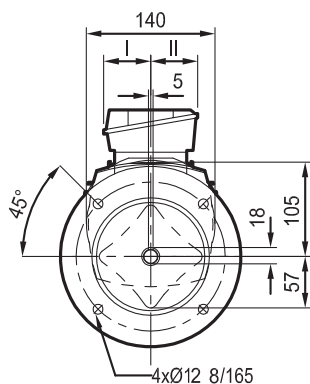





Dimensions in millimetres

**Feet S**

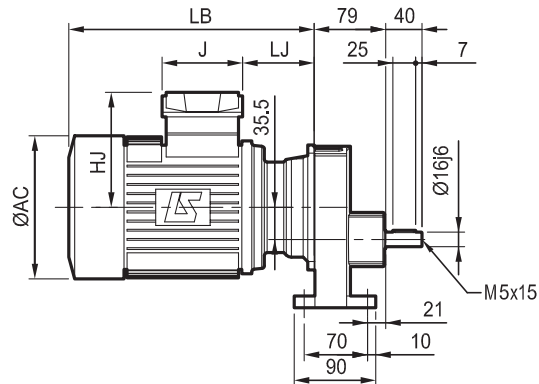
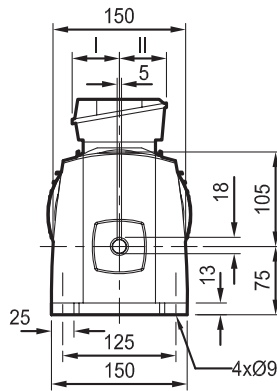
 Cb: 2.3 kg + Motor



**Standard flange BS**

 Cb: 2.5 kg + Motor

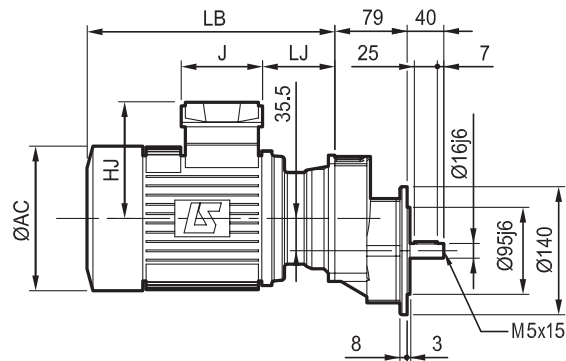
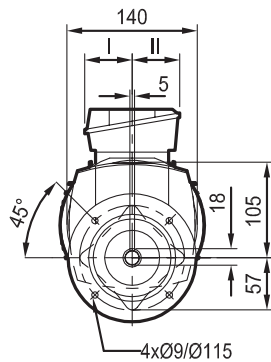

**Cb 30 MI 1-ph**

Motor type	Single phase 4-pole motors							
	AC	HJ	J	LB1 / LB2	LJ	I	II	
LS 56 M_P	110	92	100	167 / 146	17	90	44	3.5
LS 63 M_P	124	97	100	183 / 162	27	100	103	5
LS 71 L_P	140	107	100	205 / 184	34.5	100	103	7.5

LB1: ventilated motor

LB2: not ventilated motor

Motor type	Brake type	Single phase 4-pole motors and brake							
		AC	HJ	J	LB1 / LB2	LJ	I	II	
LS 56 M_P	FMD	110	114	138	217 / 196	24.5	90	44	4.7
LS 63 M_P	FMD	124	119	138	233 / 212	34.5	100	103	5.7
LS 71 L_P	FMD	140	129	138	251 / 230	34.5	100	103	8.9

**Cb 30 MI 3-ph**

Motor type	IMfinity® three-phase 4-pole motors							
	AC	HJ	J	LB	LJ	I	II	
LS 56 M	110	85	80	167	28	40	40	4
LSES 63 M	124	90	80	183	38	40	40	5
LSES 71 M	140	100	80	219,5	60,5	40	40	7,3
LSES 71 LR	140	109	80	265	57	43	43	8,3
LSES 80 LG	190	135	87	308	87,5	43	43	14,1

Motor type	Brake type	IMfinity® three-phase 4-pole motors and brake							
		AC	HJ	J	LB	LJ	I	II	
LS 56 M	FMD	110	90	85	206	13.5	43	43	4.9
LS 63 M	FMD	124	96	85	222	23.5	43	43	5.9
LS 71 M	FFB 1	140	130	160	319.5	45.5	55	55	10.3
LS 71 L	FFB 1	140	130	160	319.5	45.5	55	55	11.3
LS 80 L	FFB 1	170	141	160	367	69.5	55	55	13.9
LSES 80 LG	FFB 1	190	151	160	450	74.5	55	55	18

Dimensions

**Cb 3131 - Built-in mounting MI**

Dimensions in millimetres

**Tapped form BT**



Cb: 6.9 kg + Motor

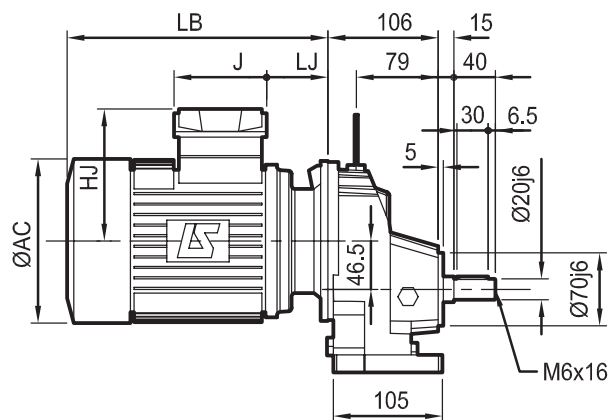
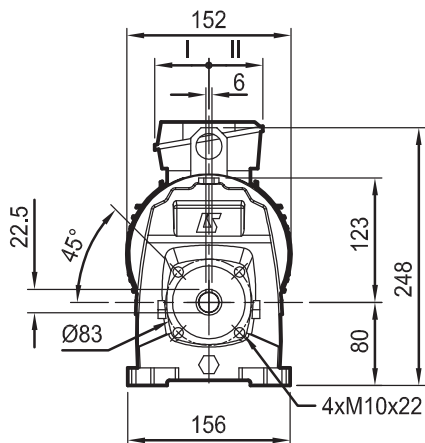

**Flange BD1**



Cb: 7.9 kg  
+ Motor

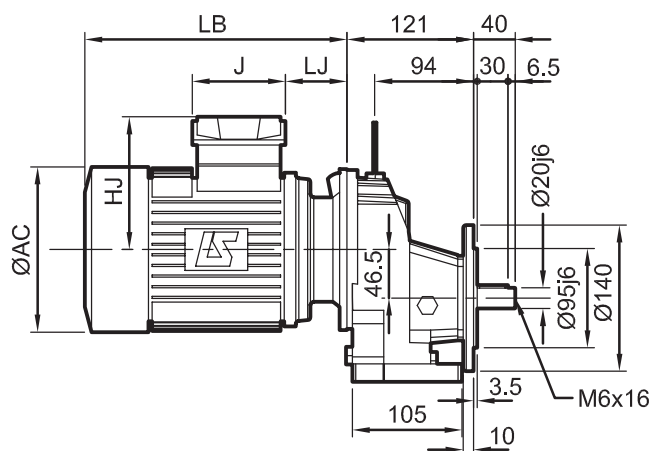
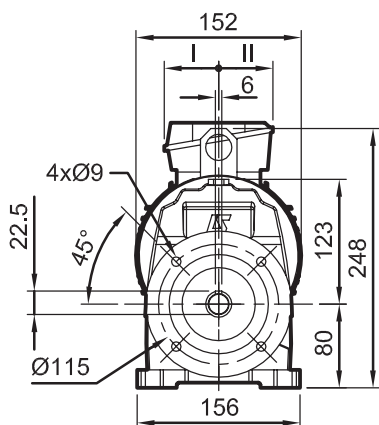

**Flange BD2**



Cb: 7.8 kg  
+ Motor

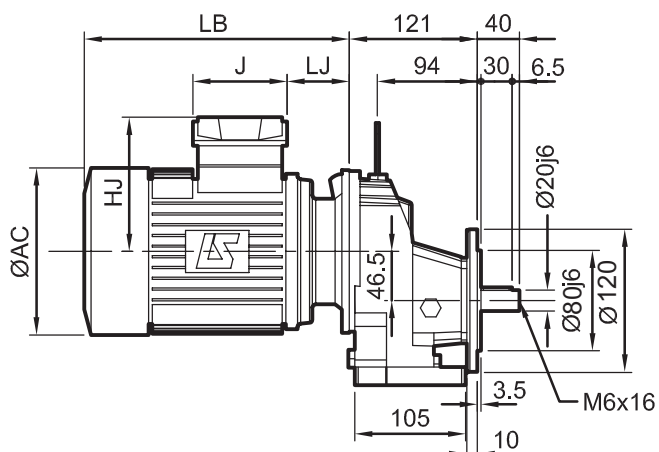
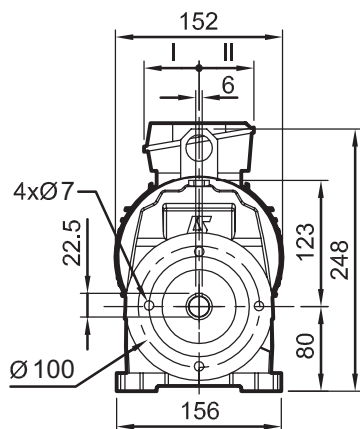

Dimensions  
**Cb 3131 - Built-in mounting MI**

Dimensions in millimetres

**Feet S**

  
Cb: 6.9 kg  
+ Motor

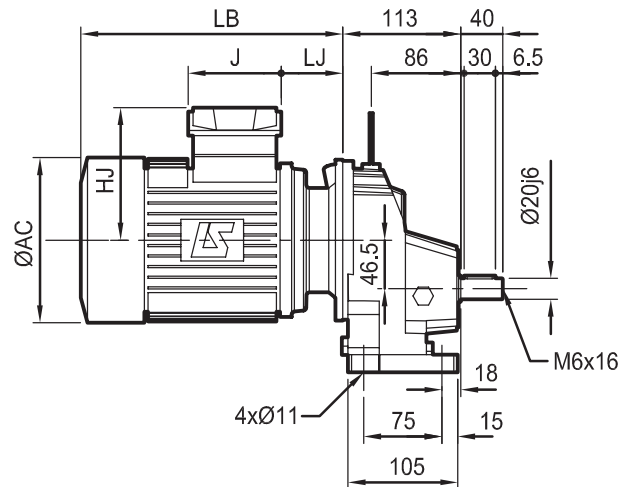
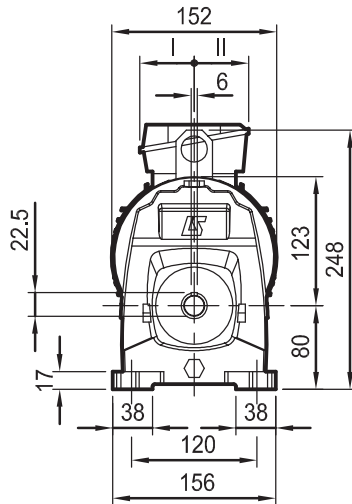

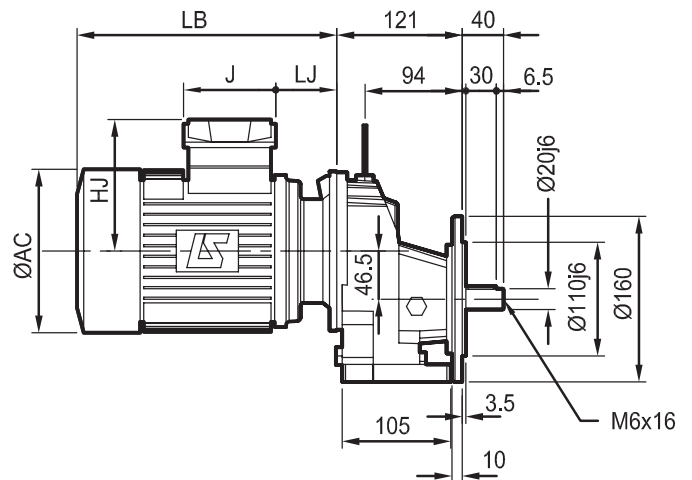
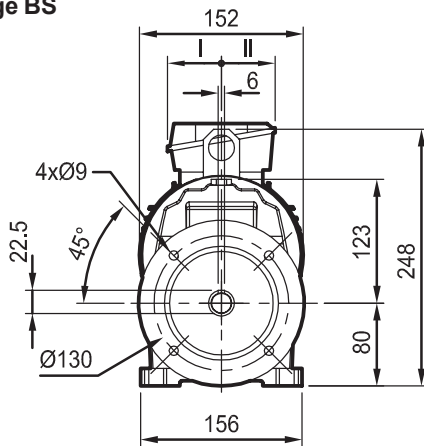

**Standard flange BS**

  
Cb: 8.1 kg  
+ Motor



**Cb 31**

Motor type	IMfinity® three-phase 4-pole motors							 kg
	AC	HJ	J	LB	LJ	I	II	
LSES 71 M	140	109	87	199,5	37	43,5	43,5	7,3
LSES 71 LR	140	109	87	247	41	43,5	43,5	8,3
LSES 80 LG	190	135	87	288	67,5	43,5	43,5	14,1
LSES 90 SL	190	135	87	290	71	43,5	43,5	16,2
LSES 90 LU	190	135	87	321,5	71	43,5	43,5	20,4
LSES 100 L	200	140	87	335,5	72	43,5	43,5	23
LSES 100 LR	200	140	87	354,5	72	43,5	43,5	25,8
LSES 100 LG	235	149	87	350,5	71	43,5	43,5	31

Motor type	Brake type	IMfinity® three-phase 4-pole motors and brak							 kg
		AC	HJ	J	LB	LJ	I	II	
LS 71 M	FFB 1	140	130	160	299,5	25,5	55	55	11,3
LS 71 L	FFB 1	140	130	160	305,5	25,5	55	55	11,3
LS 80 L	FFB 1	170	141	160	347	49,5	55	55	13,9
LSES 80 LG	FFB 1	190	151	160	430	55,5	55	55	18
LS 90 SL	FFB 2	190	151	160	434,5	59	55	55	18,2
LSES 90 SL	FFB 2	190	151	160	434,5	59	55	55	22,4
LS 90 L	FFB 2	190	151	160	434,5	59	55	55	21
LSES 90 LU	FFB 2	190	151	160	434,5	59	55	55	26,6
LS 100 L	FFB 2	200	156	160	482,5	60	55	55	29,6
LSES 100 L	FFB 2	200	156	160	482,5	60	55	55	29,6
LSES 100 LR	FFB 2	200	156	160	482,5	60	55	55	32
LSES 100 LG	FFB 3	235	165	160	458,5	59	55	55	37,6

Dimensions

**Cb 3231 - Built-in mounting MI**

Dimensions in millimetres

**Tapped form BT**

  
Cb: 8.3 kg  
+ Motor

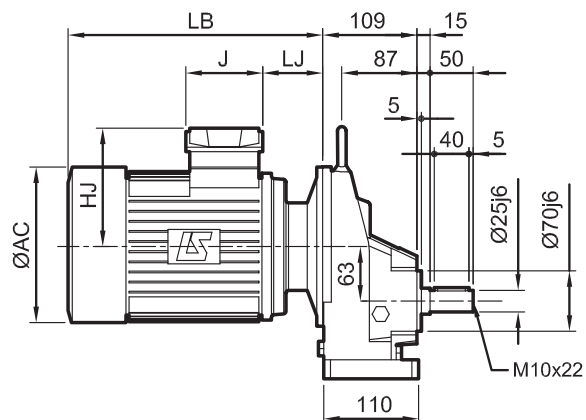
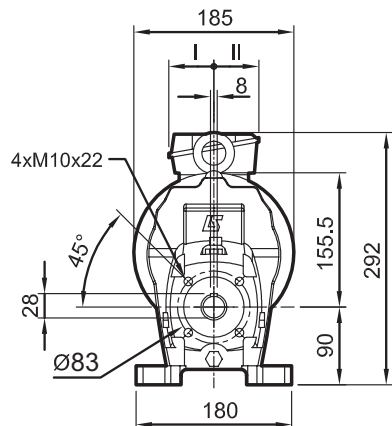

**Flange BD1**

  
Cb: 9.5 kg  
+ Motor

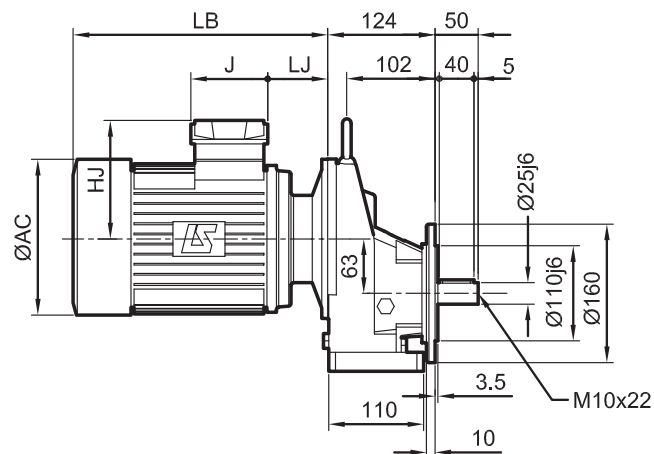
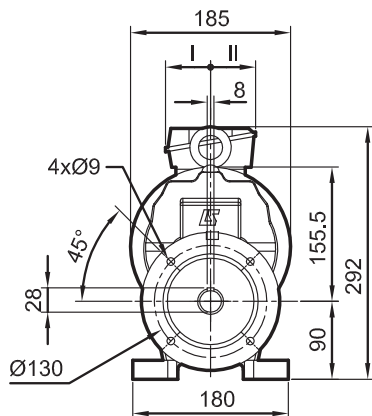

Dimensions

**Cb 3231 - Built-in mounting MI**

Dimensions in millimetres

**Feet S**

 Cb: 8.3 kg  
+ Motor

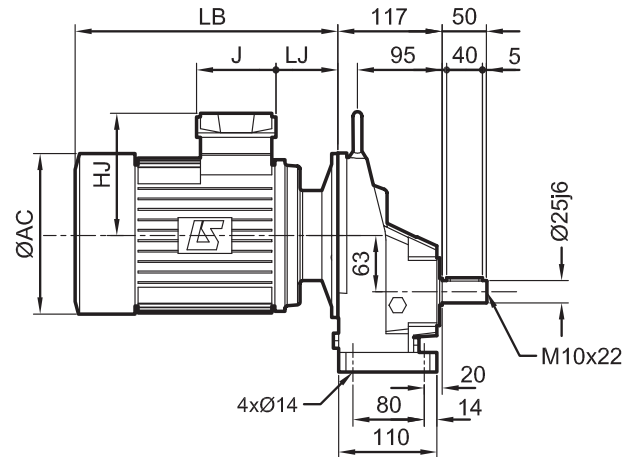
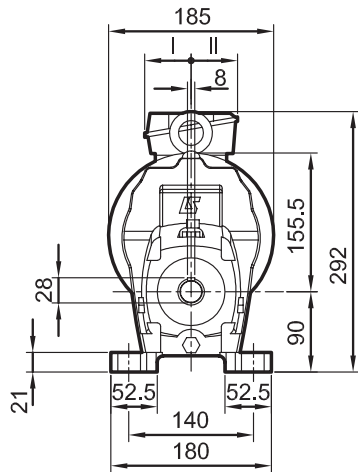

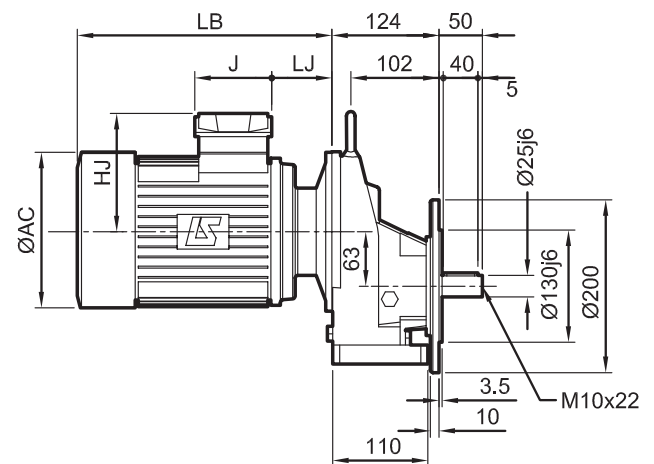
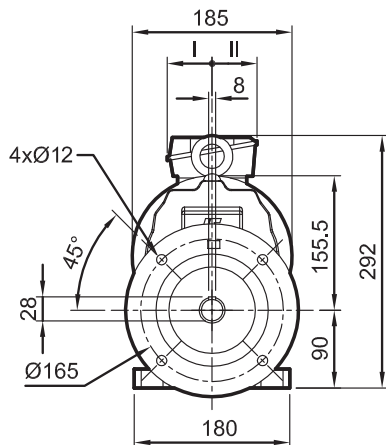

**Standard flange BS**

 Cb: 10.3 kg  
+ Motor



**Cb 32**

Motor type	IMfinity® three-phase 4-pole motors							 kg
	AC	HJ	J	LB	LJ	I	II	
LSES 71 M	140	109	87	199,5	37	43,5	43,5	7,3
LSES 71 LR	140	109	87	247	41	43,5	43,5	8,3
LSES 80 LG	190	135	87	288	67,5	43,5	43,5	14,1
LSES 90 SL	190	135	87	290	71	43,5	43,5	16,2
LSES 90 LU	190	135	87	321,5	71	43,5	43,5	20,4
LSES 100 L	200	140	87	335,5	72	43,5	43,5	22,6
LSES 100 LR	200	140	87	354,5	72	43,5	43,5	25,8
LSES 100 LG	235	149	87	350,5	71	43,5	43,5	31
LSES 112 MU	235	149	87	368,5	71	43	43	37
LSES 132 SM	272	190	126	437	69	63	63	52

Motor type	Brake type	IMfinity® three-phase 4-pole motors and brake						 kg
		AC	HJ	J	LB	LJ	I	
LS 71 M	FFB 1	140	130	160	295,5	21,5	55	10,3
LS 71 L	FFB 1	140	130	160	295,5	21,5	55	11,3
LS 80 L	FFB 1	170	141	160	347	49,5	55	13,9
LSES 80 LG	FFB 1	190	151	160	430	55,5	55	17,1
LS 90 SL	FFB 2	190	151	160	434,5	59	55	18,2
LSES 90 SL	FFB 2	190	151	160	434,5	59	55	22,4
LS 90 L	FFB 2	190	151	160	434,5	59	55	21
LSES 90 LU	FFB 2	190	151	160	434,5	59	55	26,6
LS 100 L	FFB 2	200	156	160	482,5	60	55	29,1
LSES 100 L	FFB 2	200	156	160	482,5	60	55	29,6
LSES 100 LR	FFB 2	200	156	160	482,5	60	55	32
LSES 100 LG	FFB 3	235	165	160	458,5	59	55	37,6
LS 112 MG	FFB 3	235	165	160	486	61,5	55	37,6
LSES 112 MU	FFB 3	235	165	160	483,5	59	55	40,9
LS 132 S	FFB 3	227	168	160	509	60,5	55	44,6
LSES 132 SM	FFB 4	272	186	160	648	77,5	55	66,5

Dimensions

**Cb 3331 - Built-in mounting MI**

Dimensions in millimetres

**Tapped form BT**

  
Cb: 15.5 kg  
+ Motor

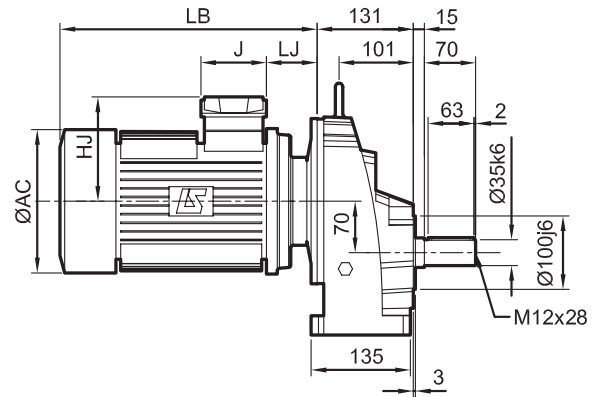
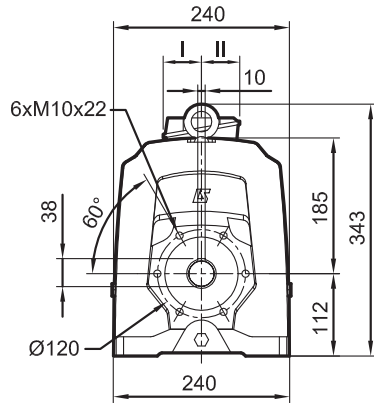

**Flange BD1**

  
Cb: 18.3 kg  
+ Motor

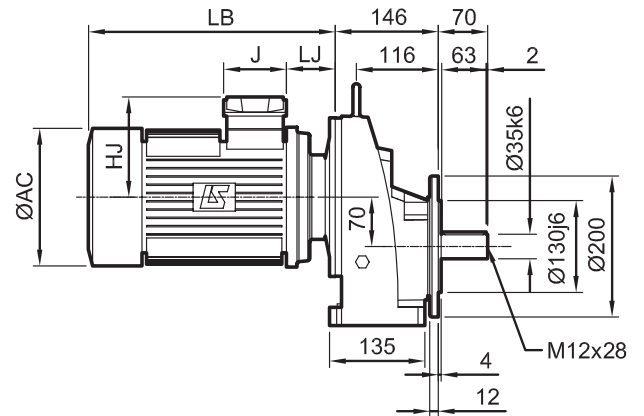
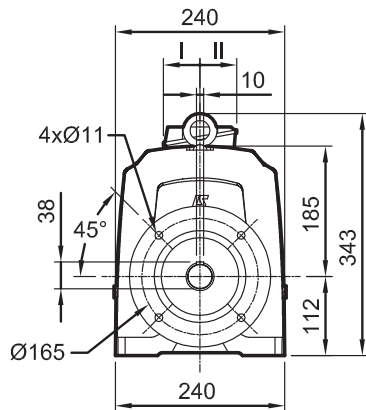

Dimensions

**Cb 3331 - Built-in mounting MI**

Dimensions in millimetres

**Feet S**

  
Cb: 15.5 kg  
+ Motor

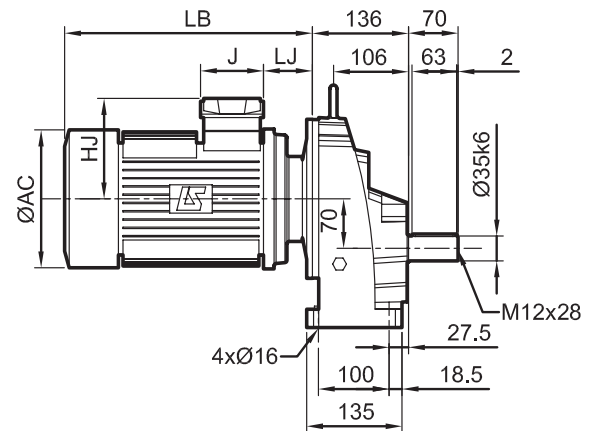
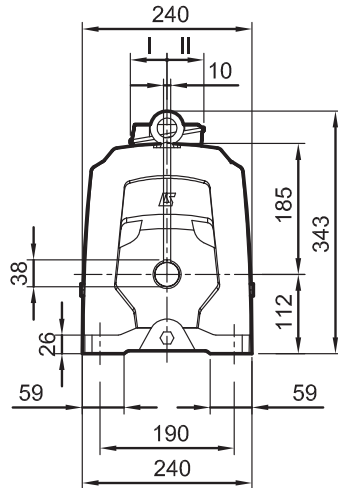

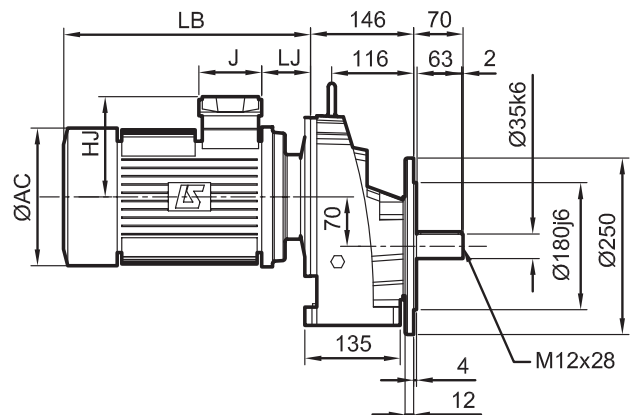
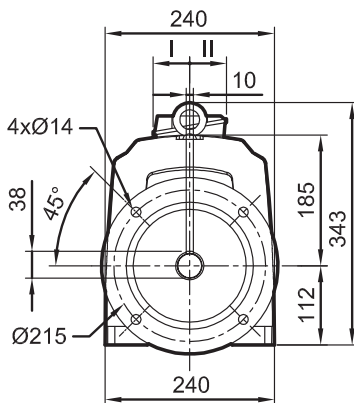

**Standard flange BS**

  
Cb: 19.4 kg  
+ Motor



**Cb 33**

Motor type	IMfinity® three-phase 4-pole motors							 kg
	AC	HJ	J	LB	LJ	I	II	
LSES 71 M	140	109	87	195,5	33	43	43	7,3
LSES 71 LR	140	109	87	243	37	43	43	9
LSES 80 LG	190	135	87	284	63,5	43	43	15
LSES 90 SL	190	135	87	286	67	43	43	16,2
LSES 90 LU	190	135	87	317,5	67	43	43	20,4
LSES 100 L	200	140	87	331,5	68	43	43	23
LSES 100 LR	200	140	87	331,5	68	43	43	25,8
LSES 100 LG	235	149	87	346,5	67	43	43	31
LSES 112 MU	235	149	87	364,5	67	43	43	37
LSES 132 SM	272	190	126	433	65	63	63	52
LSES 132 MU	272	190	126	460	65	63	63	62,6

Motor type	Brake type	IMfinity® three-phase 4-pole motors and brake								 kg
		AC	HJ	J	LB	LJ	I	II		
LS 71 M	FFB 1	140	130	160	295,5	21,5	55	55	10,3	
LS 71 L	FFB 1	140	130	160	295,5	21,5	55	55	11,3	
LS 80 L	FFB 1	170	141	160	343	45,5	55	55	13,9	
LSES 80 LG	FFB 1	190	151	160	426	51,5	55	55	18	
LS 90 SL	FFB 2	190	151	160	430,5	55	55	55	18,2	
LSES 90 SL	FFB 2	190	151	160	430,5	55	55	55	22,4	
LS 90 L	FFB 2	190	151	160	430,5	55	55	55	21	
LSES 90 LU	FFB 2	190	151	160	430,5	55	55	55	26,6	
LS 100 L	FFB 2	200	156	160	478,5	56	55	55	29,1	
LSES 100 L	FFB 2	200	156	160	478,5	56	55	55	29,6	
LSES 100 LR	FFB 2	200	156	160	478,5	56	55	55	32	
LSES 100 LG	FFB 3	235	165	160	454,5	55	55	55	37,6	
LS 112 MG	FFB 3	235	165	160	448	28,5	55	55	37,6	
LSES 112 MU	FFB 3	235	165	160	479,5	55	55	55	40,9	
LS 132 S	FFB 3	227	168	160	505	56,5	55	55	44,6	
LSES 132 SM	FFB 4	272	186	160	644	73,5	55	55	66,5	
LS 132 M	FFB 4	272	186	160	644	73,5	55	55	67,4	
LSES 132 MU	FFB 4	272	186	160	644	73,5	55	55	77,1	

Dimensions

**Cb 3431 - Built-in mounting MI**

**Tapped form BT**

Dimensions in millimetres

 Cb: 25 kg  
+ Motor

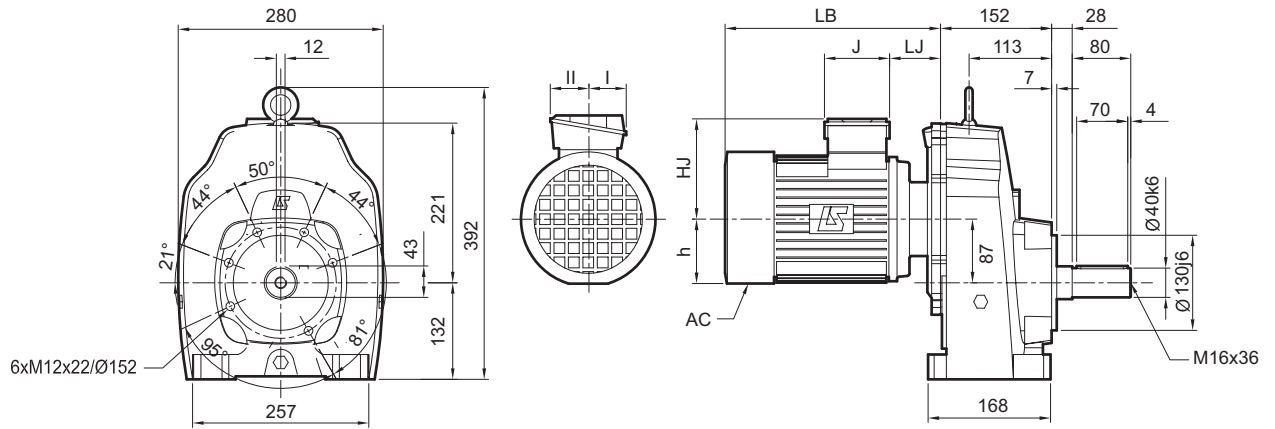

**Flange BD1**

 Cb: 29.5 kg  
+ Motor

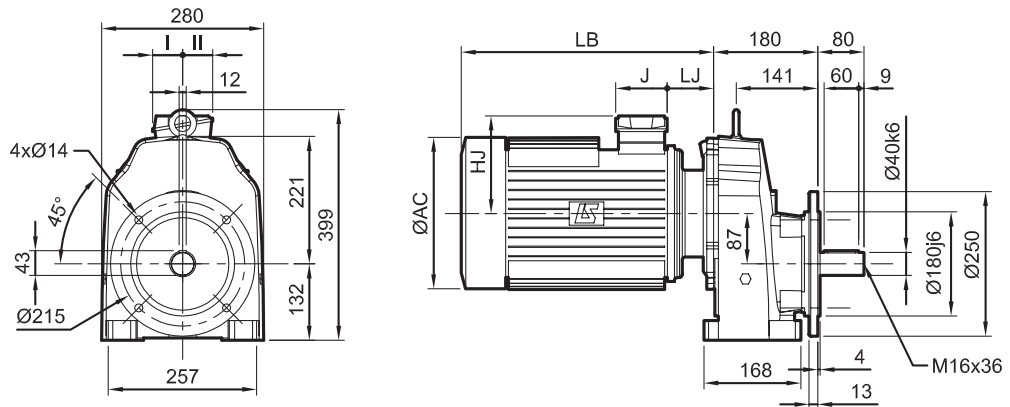



Dimensions

Cb 3431 - Built-in mounting MI

Feet S

 Cb: 25 kg  
+ Motor

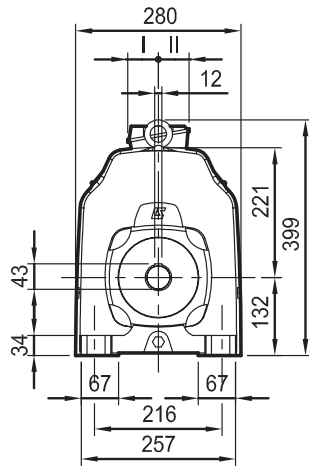

Dimensions in millimetres

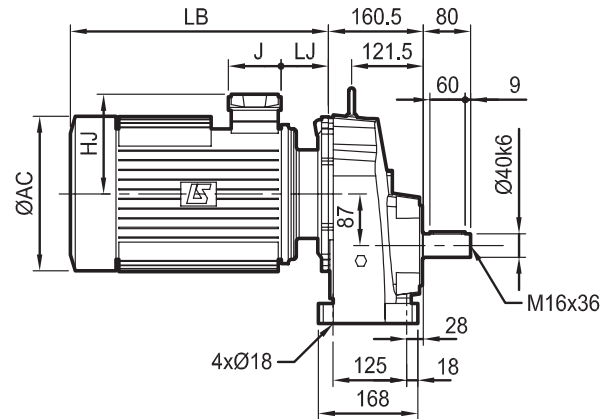

Standard flange BS

 Cb: 31 kg  
+ Motor

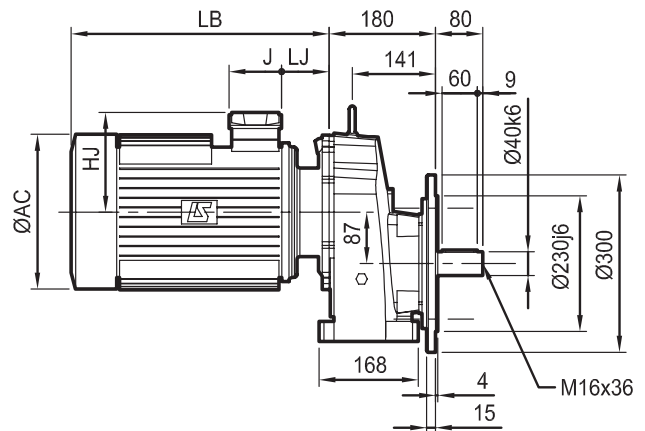
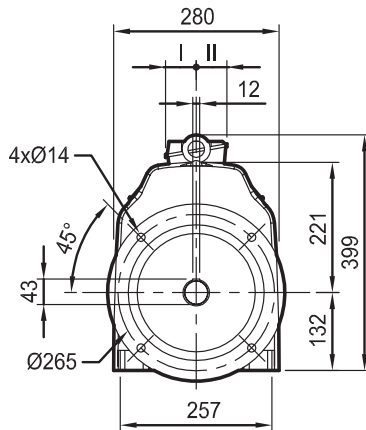

Cb 34

Motor type	IMfinity® three-phase 4-pole motors							kg
	AC	HJ	J	LB	LJ	I	II	
LSES 80 LG	190	135	87	288,5	68	43	43	15
LSES 90 SL	190	135	87	286	67	43	43	16,2
LSES 90 LU	190	135	87	317,5	67	43	43	20,4
LSES 100 L	200	140	87	331,5	68	43	43	23
LSES 100 LR	200	140	87	350,5	68	43	43	25,8
LSES 100 LG	235	149	87	346,5	67	43	43	31
LSES 112 MU	235	149	87	364,5	67	43	43	37
LSES 132 SM	272	190	126	437	69	63	63	52
LSES 132 MU	272	190	126	464	69	63	63	62,6
LSES 160 MR	272	190	126	506	69,5	63	63	78
LSES 160 M	312	235	135	508	55,8	88	64	93
LSES 160 LUR	312	235	135	523	55,8	88	64	100
LSES 180 M	350	256	186	565	76,5	112	98	130
LSES 180 LUR	350	256	186	627	76,5	112	98	155

Motor type	Brake type	IMfinity® three-phase 4-pole motors and brake <sup>1</sup>							kg
		AC	HJ	J	LB	LJ	I	II	
LS 80 L	FFB 1	170	141	160	347,5	50	55	55	13,9
LSES 80 LG	FFB 1	190	151	160	430,5	56	55	55	18
LS 90 SL	FFB 2	190	151	160	430,5	55	55	55	18,2
LSES 90 SL	FFB 2	190	151	160	430,5	55	55	55	22,4
LS 90 L	FFB 2	190	151	160	430,5	55	55	55	21
LSES 90 LU	FFB 2	190	151	160	430,5	55	55	55	26,6
LS 100 L	FFB 2	200	156	160	478,5	56	55	55	29,1
LSES 100 L	FFB 2	200	156	160	478,5	55	55	55	29,6
LSES 100 LR	FFB 2	200	156	160	478,5	55	55	55	32
LSES 100 LG	FFB 3	235	165	160	454,5	55	55	55	37,6
LS 112 MG	FFB 3	235	165	160	482	28,5	55	55	37,6
LSES 112 MU	FFB 3	235	165	160	479,5	55	55	55	40,9
LS 132 S	FFB 3	227	168	160	509	60,5	55	55	44,6
LSES 132 SM	FFB 4	272	186	160	648	77,5	55	55	66,5
LS 132 M	FFB 4	272	186	160	648	77,5	55	55	67,4
LSES 132 MU	FFB 4	272	186	160	648	77,5	55	55	77,1
LSES 160 MR	FFB 4	272	186	160	683	77	55	55	92,3
LS 160 MP	FFB 5	272	186	160	682	77	55	55	83,2
LS 160 LR	FFB 5	272	186	160	682	77	55	55	96,1
LSES 160 M	FFB 5	312	248	186	695	59	112	98	110
LSES 160 LUR	FFB 5	312	248	186	690	59	112	98	117
LS 180 MT	FFB 5	312	248	186	695	59	112	98	117
LS 180 LR	FCPL 54HID	312	235	134	696	57	92	63	152

<sup>1</sup> except brake motor in italics

Dimensions in millimetres

**Tapped form BT**

 Cb: 41 kg  
+ Motor

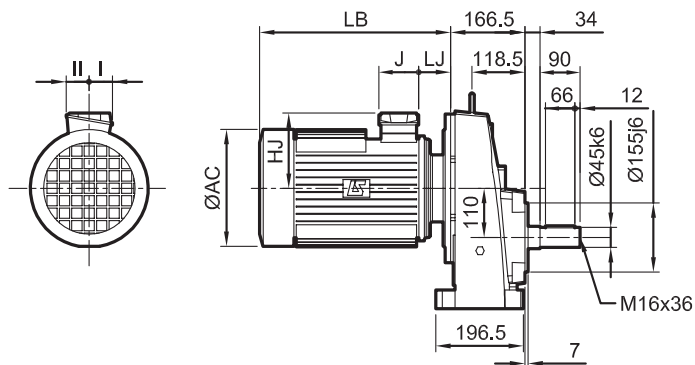
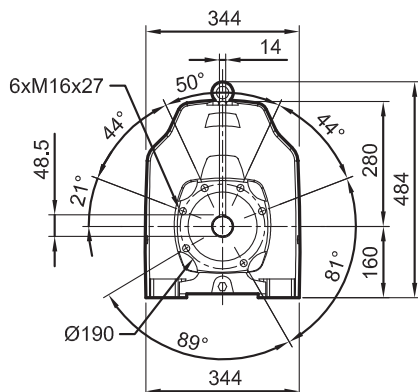

**Flange BD1**

 Cb: 46 kg  
+ Motor

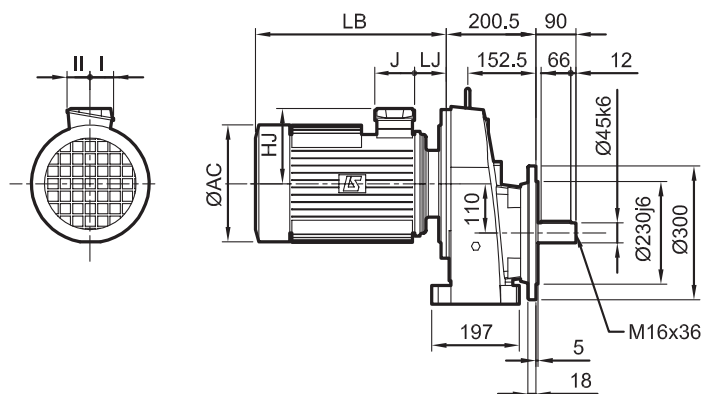
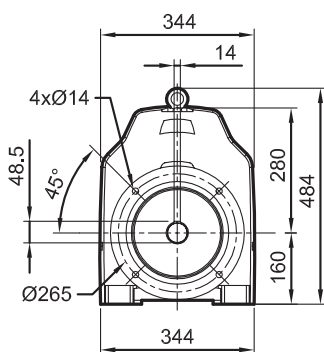

Dimensions

Cb 3531 - Built-in mounting MI

Dimensions in millimetres

Feet S

 Cb: 41 kg  
+ Motor

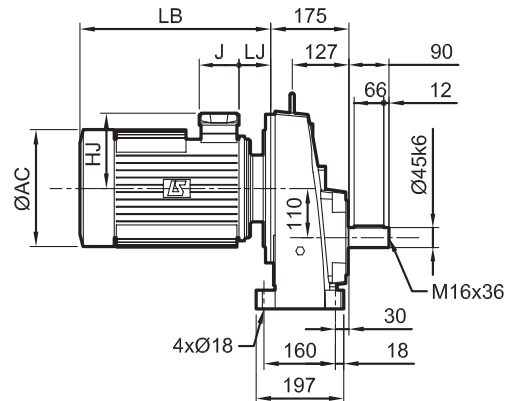
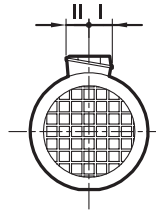
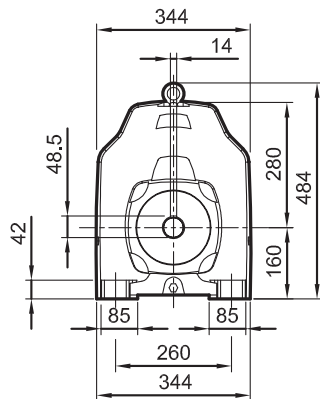

Standard flange BS

 Cb: 48 kg  
+ Motor

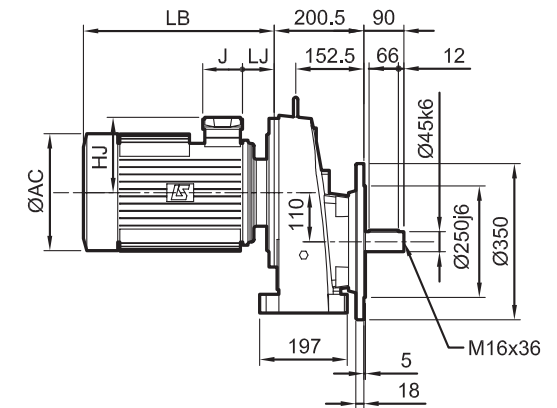
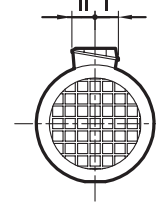
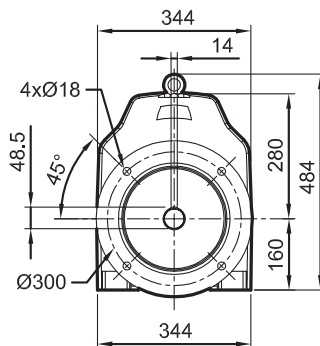

Cb 35

Motor type	IMfinity® three-phase 4-pole motors							kg
	AC	HJ	J	LB	LJ	I	II	
LSES 90 SL	190	135	87	281	62	43	43	16,2
LSES 90 LU	190	135	87	312,5	62	43	43	20,4
LSES 100 L	200	140	87	326,5	63	43	43	22,6
LSES 100 LR	200	140	87	345,5	63	43	43	25,8
LSES 100 LG	235	149	87	341,5	62	43	43	31
LSES 112 MU	235	149	87	359,5	62	43	43	37
LSES 132 SM	272	190	126	428	60	63	63	52
LSES 132 MU	272	190	126	455	60	63	63	62,6
LSES 160 MR	272	190	126	498	61,5	63	63	77,8
LSES 160 M	312	235	135	499	46,8	88	64	93
LSES 160 LUR	312	235	135	514	46,8	88	64	100
LSES 180 M	350	256	186	556	67,5	112	98	130
LSES 180 LUR	350	256	186	618	67,5	112	98	155
LSES 200 LU	390	276	186	683	91	112	98	225

Motor type	Brake type	IMfinity® three-phase 4-pole motors and brake <sup>1</sup>							kg
		AC	HJ	J	LB	LJ	I	II	
LS 90 SL	FFB 2	190	151	160	425,5	50	55	55	18,2
LSES 90 SL	FFB 2	190	151	160	425,5	50	55	55	22,4
LS 90 L	FFB 2	190	151	160	425,5	50	55	55	21
LSES 90 LU	FFB 2	190	151	160	425,5	50	55	55	26,6
LS 100 L	FFB 2	200	156	160	473,5	51	55	55	29,1
LSES 100 L	FFB 2	200	156	160	473,5	50	55	55	29,6
LSES 100 LR	FFB 2	200	156	160	473,5	50	55	55	32
LSES 100 LG	FFB 3	235	165	160	449,5	50	55	55	37,6
LS 112 MG	FFB 3	235	165	160	477	52,5	55	55	37,6
LSES 112 MU	FFB 3	235	165	160	474,5	50	55	55	40,9
LS 132 S	FFB 3	227	168	160	500	51,5	55	55	44,6
LSES 132 SM	FFB 4	272	186	160	639	68,5	55	55	66,5
LS 132 M	FFB 4	272	186	160	639	68,5	55	55	67,4
LSES 132 MU	FFB 4	272	186	160	639	68,5	55	55	77,1
LSES 160 MR	FFB 4	272	186	160	674	69,5	55	55	92,3
LS 160 MP	FFB 5	272	186	160	674	69,5	55	55	82,9
LS 160 LR	FFB 5	272	186	160	674	69,5	55	55	96,1
LSES 160 M	FFB 5	312	248	186	686	50	112	98	110
LSES 160 LUR	FFB 5	312	248	186	686	50	112	98	117
LS 180 MT	FFB 5	312	248	186	686	50	112	98	117
LS 180 LR	<i>FCPL 54H1D</i>	312	235	134	687	48	92	63	152
LS 200 LT	<i>FCPL 54H1D<sup>2</sup></i>	350	263	134	783	95	92	63	200

<sup>1</sup> except brake motor in italics

<sup>2</sup> with CDF board

Dimensions

**Cb 15 - Built-in mounting MI**

Dimensions in millimetres

**Tapped form BT**

  
Cb: 2.9 kg  
+ Motor

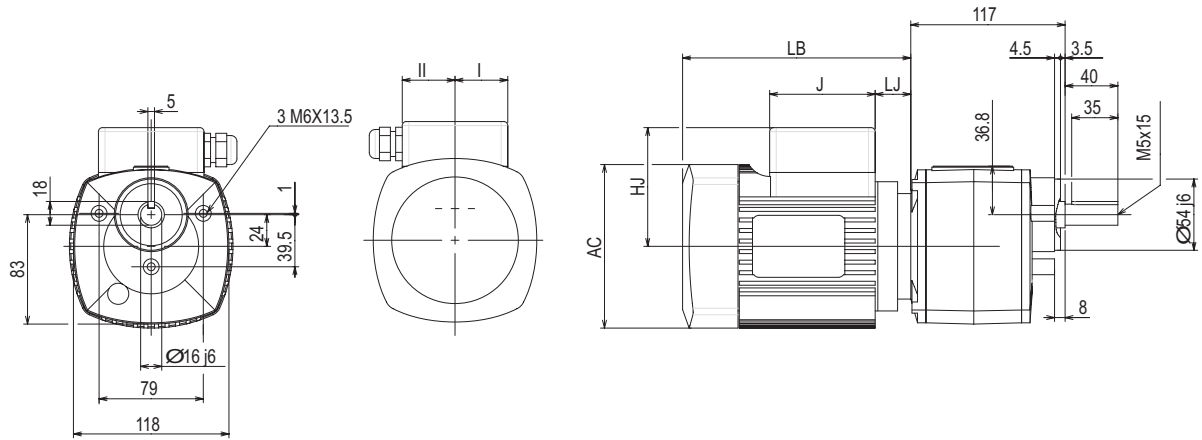

**Flange BD1**

  
Cb: 2.8 kg  
+ Motor

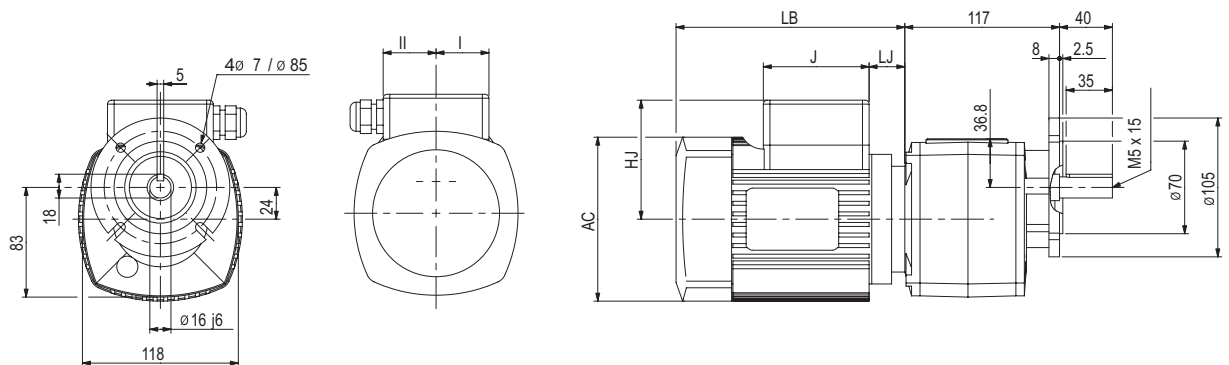

**Flange BD2**

  
Cb: 3 kg  
+ Motor

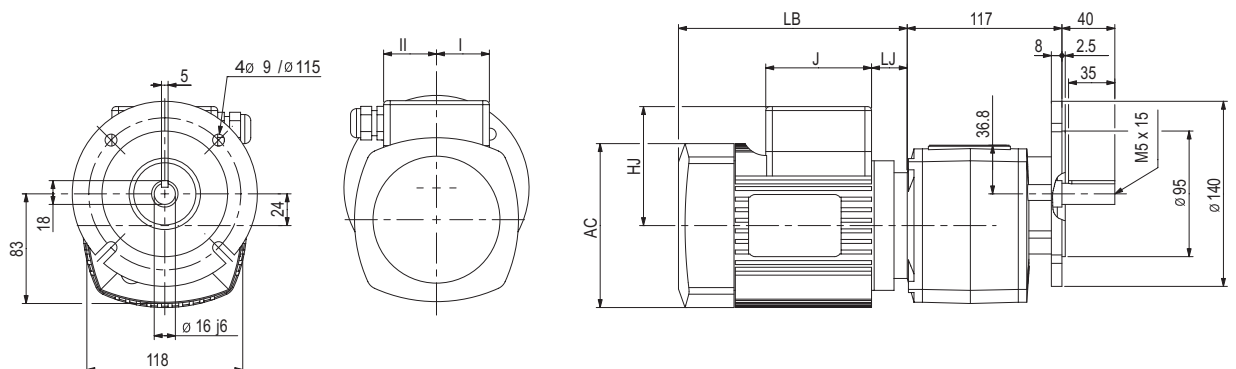

Dimensions

**Cb 15 - Built-in mounting MI**

Dimensions in millimetres

**Feet S**

 Cb: 2.9 kg  
+ Motor

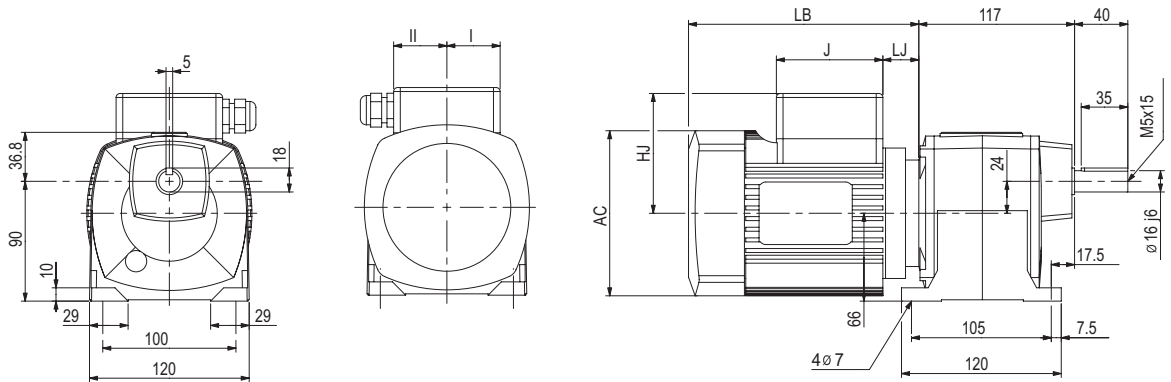

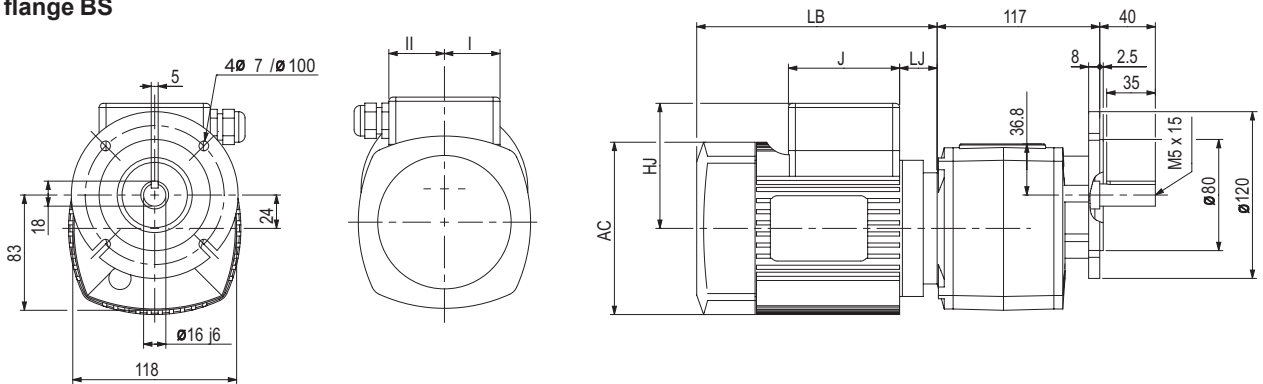

**Standard flange BS**

 Cb: 2.9 kg  
+ Motor



**Cb 15 MI 1-ph**

Motor type	Single phase 4-pole motors							 kg
	AC	HJ	J	LB1 / LB2	LJ	I	II	
LS 56 M_P	110	92	86	156/135	17	90	44	3.5
LS 63 M_P	126	97	138	172/150	27	100	103	5
LS 71 L_P	140	107	100	194	23.5	102	43	7.5

Motor type	Brake type	Single phase 4-pole motors and brake							 kg
		AC	HJ	J	LB1 / LB2	LJ	I	II	
LS 56 M_P	FMD	110	114	136	206	13.5	52	52	4.7
LS 63 M_P	FMD	124	119	136	222	23.5	52	52	5.7
LS 71 L_P	FMD	140	129	136	240	23.5	52	52	9.4

LB1: ventilated motor

LB2: not ventilated motor

**Cb 15 MI 3-ph**

Motor type	IMfinity® three-phase 4-pole motors							 kg
	AC	HJ	J	LB	LJ	I	II	
LS 56 M	110	84	80	156	17	40	40	4
LSES 63 M	124	89	80	172	27	40	40	5
LSES 71 M	140	100	80	186	27	40	40	6.4

Motor type	Brake type	IMfinity® three-phase 4-pole motors and brake							 kg
		AC	HJ	J	LB	LJ	I	II	
LS 56 M	FMD	110	114	85	206	13.5	52	52	5.2
LS 63 M	FMD	124	119	85	222	23.5	52	52	6.2
LS 71 M	FMD	140	129	136	236	23.5	52	52	8.3

Dimensions

**Cb 3032 - Built-in mounting MI**

Dimensions in millimetres

**Tapped form BT**

  
Cb: 4.6 kg  
+ Motor

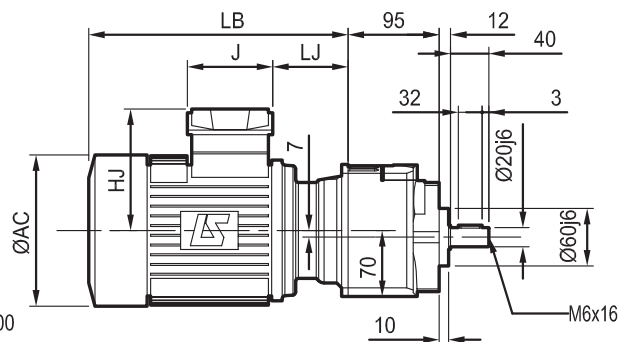
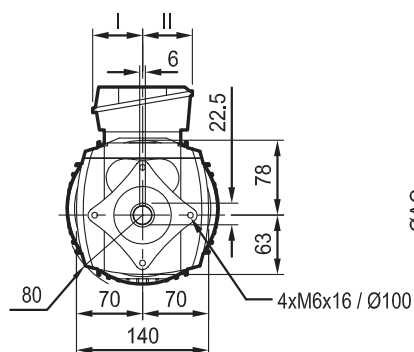

**Flange BD1**

  
Cb: 4.7 kg  
+ Motor

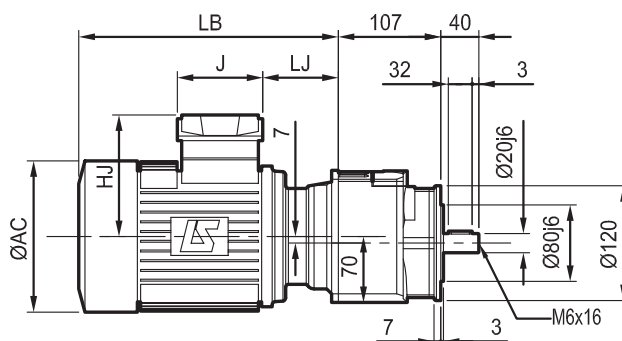
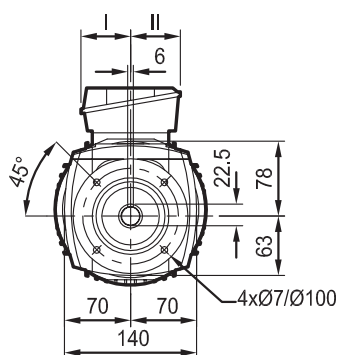

**Flange BD2**

  
Cb: 4.9 kg  
+ Motor

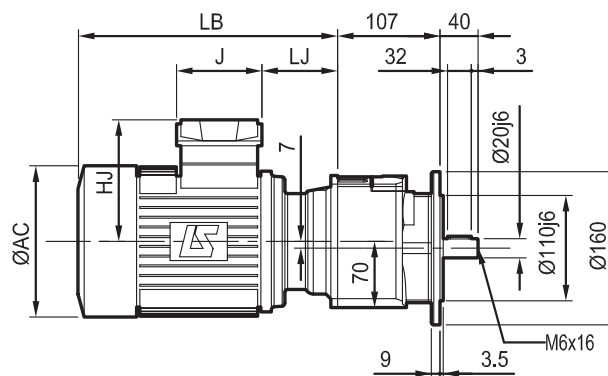
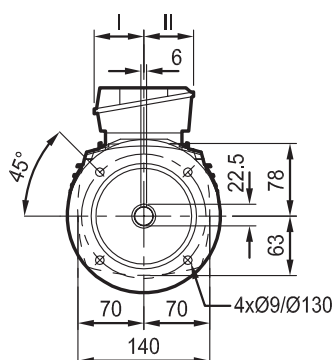

**Flange BD3**

  
Cb: 5 kg  
+ Motor

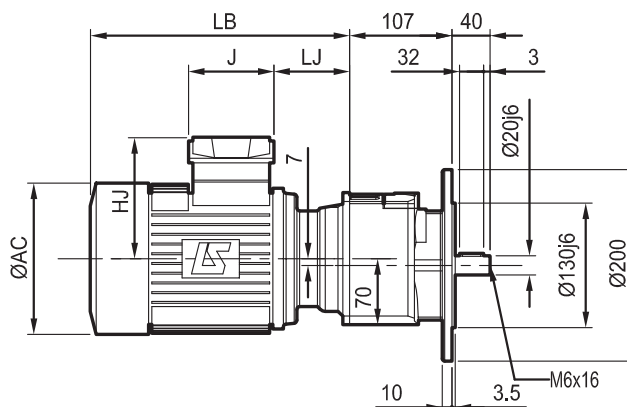
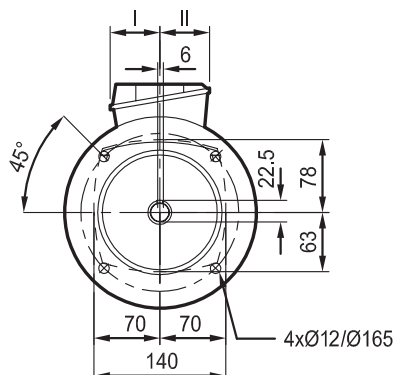

Dimensions

**Cb 3032 - Built-in mounting MI**

Dimensions in millimetres

**Feet S**

  
Cb: 4.8 kg  
+ Motor

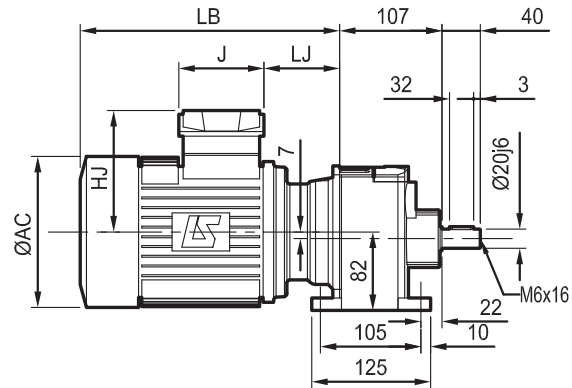
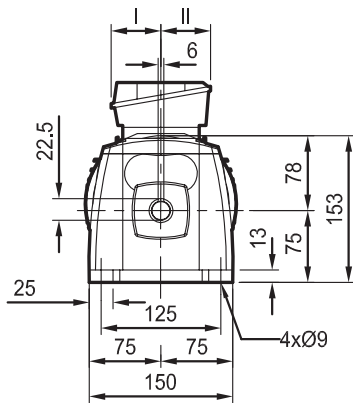

**Standard flange BS**

  
Cb: 4.8 kg  
+ Motor

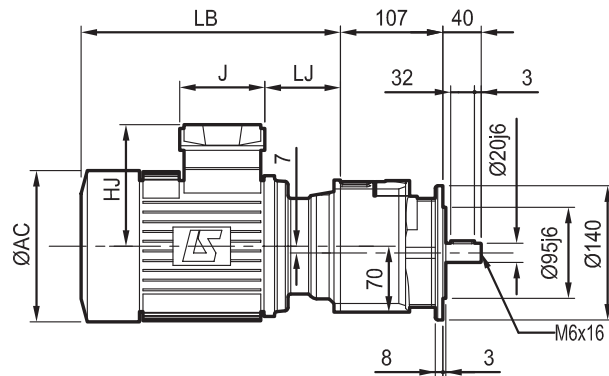
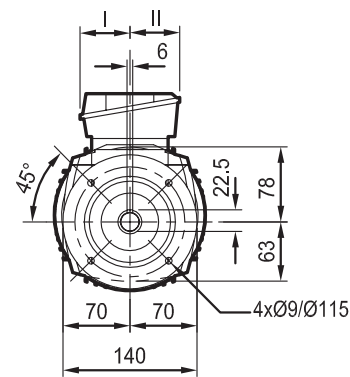

**Cb 30 MI 1-ph**

Motor type	Single phase 4-pole motors							kg
	AC	HJ	J	LB1 / LB2	LJ	I	II	
LS 56 M_P	110	92	100	167 / 146	17	90	44	3.5
LS 63 M_P	124	97	100	183 / 162	27	100	103	5
LS 71 L_P	140	107	100	205 / 184	34.5	100	103	7.5

LB1: ventilated motor

LB2: not ventilated motor

Motor type	Brake type	Single phase 4-pole motors and brake <sup>1</sup>							kg
		AC	HJ	J	LB1 / LB2	LJ	I	II	
LS 56 M_P	FMD	110	114	138	217 / 196	24.5	90	44	4.7
LS 63 M_P	FMD	124	119	138	233 / 212	34.5	100	103	5.7
LS 71 L_P	FMD	140	129	138	251 / 230	34.5	100	103	8.9

**Cb 30 MI 3-ph**

Motor type	IMfinity® three-phase 4-pole motors							kg
	AC	HJ	J	LB	LJ	I	II	
LS 56 M	110	85	80	167	28	40	40	4
LSES 63 M	124	90	80	183	38	40	40	5
LSES 71 M	140	100	80	219,5	60,5	40	40	7,3
LSES 71 LR	140	109	80	265	57	43	43	8,3
LSES 80 LG	190	135	87	308	87,5	43	43	14,1

Motor type	Brake type	IMfinity® three-phase 4-pole motors and brake							kg
		AC	HJ	J	LB	LJ	I	II	
LS 56 M	FMD	110	90	85	206	13.5	43	43	4.9
LS 63 M	FMD	124	96	85	222	23.5	43	43	5.9
LS 71 M	FFB 1	140	130	160	319.5	45.5	55	55	10.3
LS 71 L	FFB 1	140	130	160	319.5	45.5	55	55	11.3
LS 80 L	FFB 1	170	141	160	367	69.5	55	55	13.9
LSES 80 LG	FFB 1	190	151	160	450	74.5	55	55	18

Dimensions in millimetres

**Tapped form BT**

  
Cb: 4.7 kg  
+ Motor

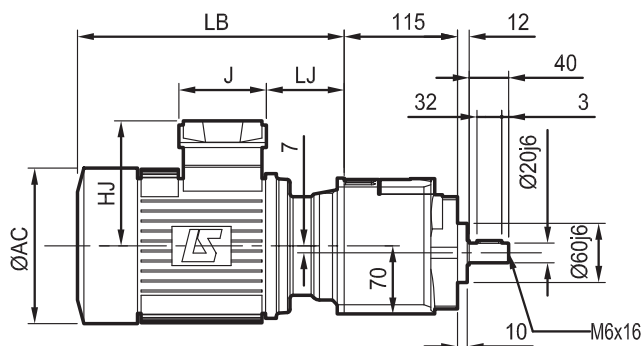
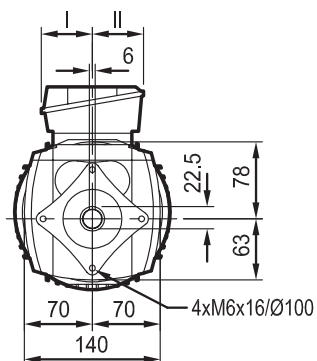

**Flange BD1**

  
Cb: 4.8 kg  
+ Motor

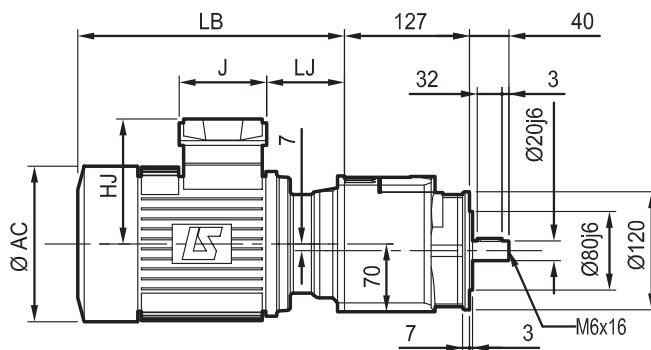
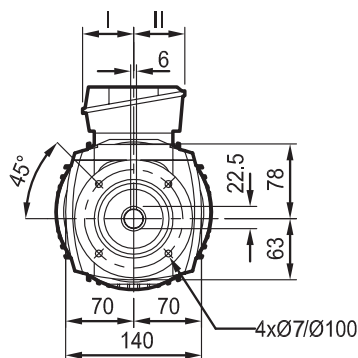

**Flange BD2**

  
Cb: 5 kg  
+ Motor

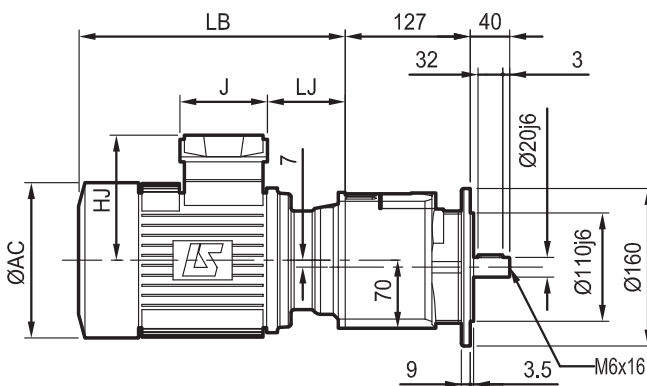
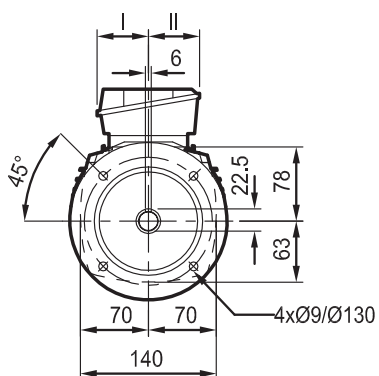

**Flange BD3**

  
Cb: 5.1 kg  
+ Motor

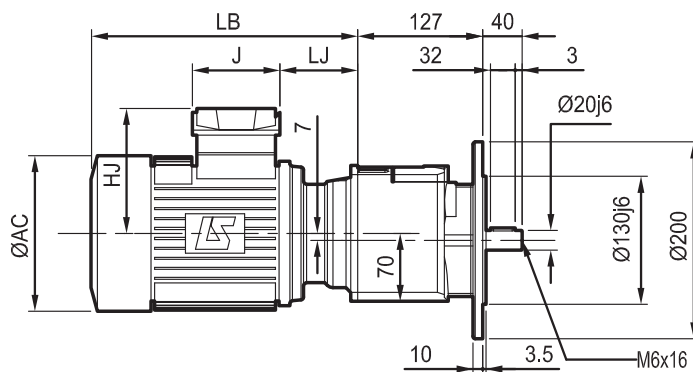
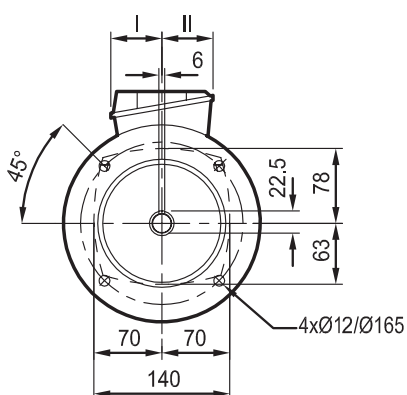



Dimensions

**Cb 3033 - Built-in mounting MI**

Dimensions in millimetres

**Feet S**

 Cb: 4.9 kg  
+ Motor

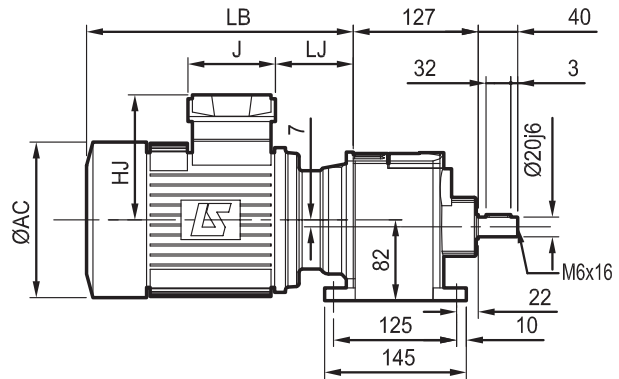
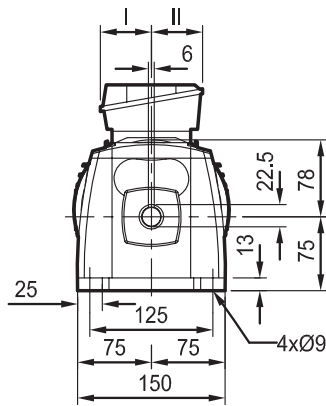

**Standard flange BS**

 Cb: 4.9 kg  
+ Motor

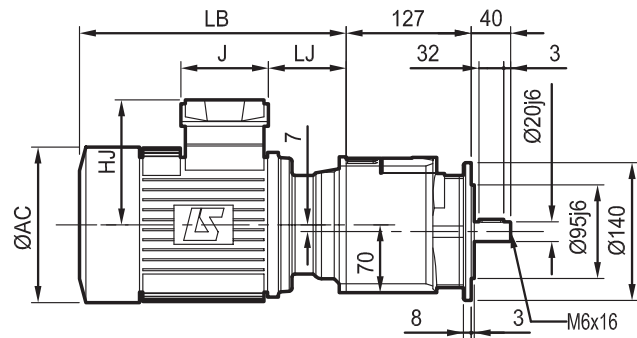
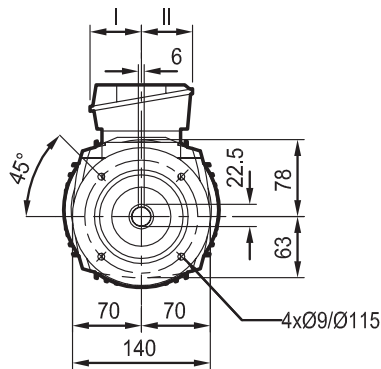

**Cb 30 MI 1-ph**

Motor type	Single phase 4-pole motors							 kg
	AC	HJ	J	LB1 / LB2	LJ	I	II	
LS 56 M_P	110	92	100	167 / 146	17	90	44	3.5
LS 63 M_P	124	97	100	183 / 162	27	100	103	5
LS 71 L_P	140	107	100	205 / 184	34.5	100	103	7.5

LB1: ventilated motor

LB2: not ventilated motor

Motor type	Brake type	Single phase 4-pole motors and brake <sup>1</sup>							 kg
		AC	HJ	J	LB1 / LB2	LJ	I	II	
LS 56 M_P	FMD	110	114	138	217 / 196	24.5	90	44	4.7
LS 63 M_P	FMD	124	119	138	233 / 212	34.5	100	103	5.7
LS 71 L_P	FMD	140	129	138	251 / 230	34.5	100	103	8.9

**Cb 30 MI 3-ph**

Motor type	IMfinity® three-phase 4-pole motors							 kg
	AC	HJ	J	LB	LJ	I	II	
LS 56 M	110	85	80	167	28	40	40	4
LSES 63 M	124	90	80	183	38	40	40	5
LSES 71 M	140	100	80	219,5	60,5	40	40	7,3

Motor type	Brake type	IMfinity® three-phase 4-pole motors and brake							 kg
		AC	HJ	J	LB	LJ	I	II	
LS 56 M	FMD	110	90	85	206	13.5	43	43	4.9
LS 63 M	FMD	124	96	85	222	23.5	43	43	5.9
LS 71 M	FFB 1	140	130	160	319.5	45.5	55	55	10.3

Dimensions in millimetres

**Tapped form BT**

 Cb: 12.7 kg  
+ Motor

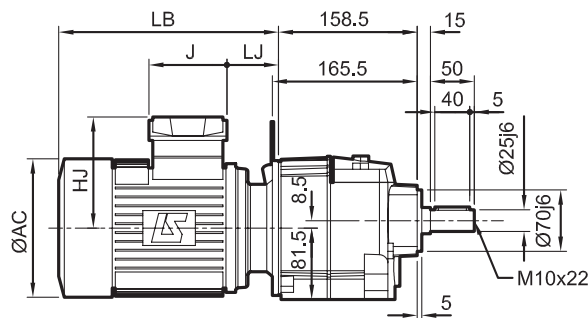
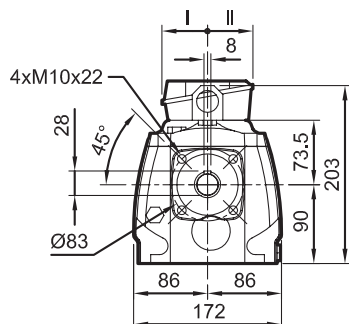

**Flange BD1**

 Cb: 13.3 kg  
+ Motor

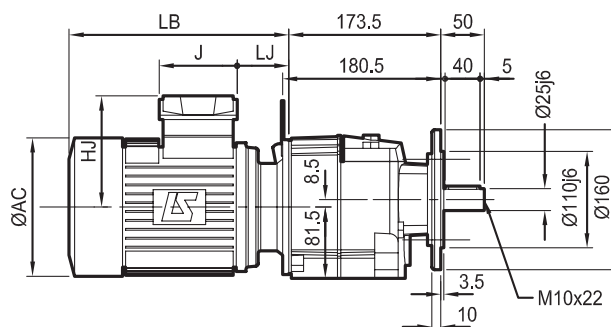
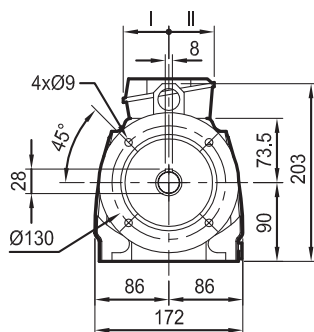

**Flange BD2**

 Cb: 13.2 kg  
+ Motor

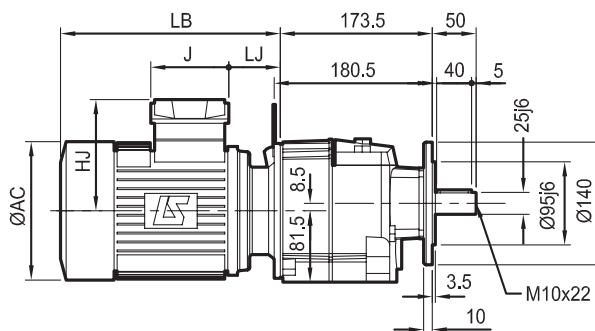
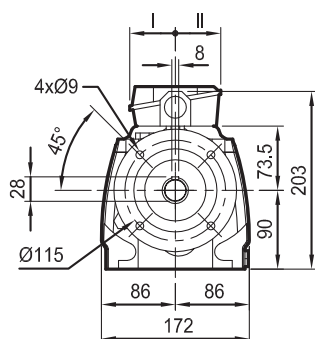

**Flange BD3**

 Cb: 13.1 kg  
+ Motor

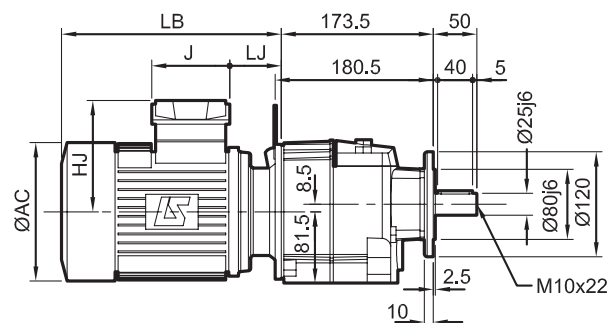
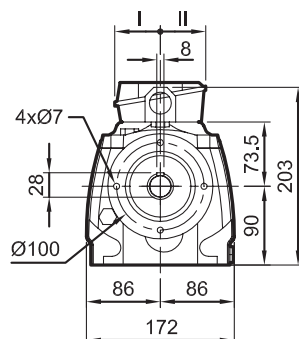

Dimensions

**Cb 3133 - Built-in mounting MI**

Dimensions in millimetres

**Feet S**

 Cb: 13 kg  
+ Motor

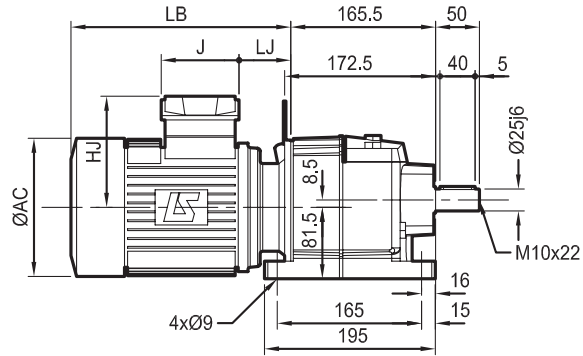
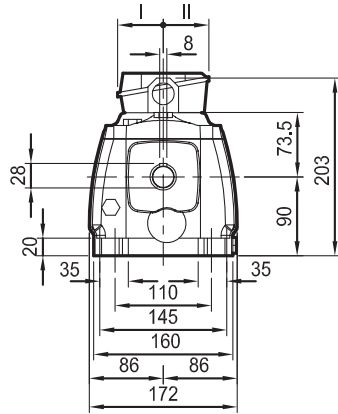

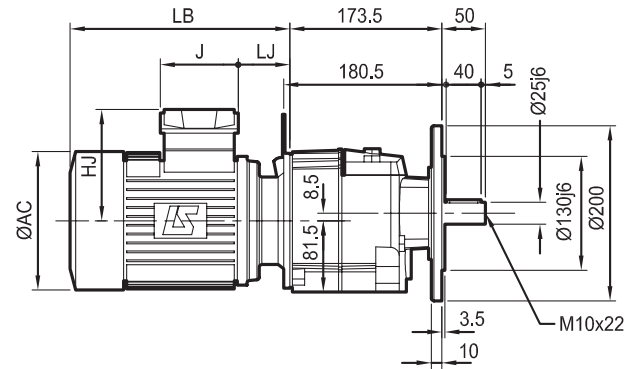
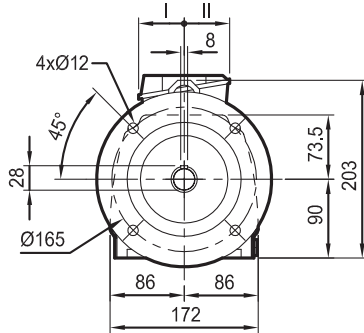

**Standard flange BS**

 Cb: 13.4 kg  
+ Motor



**Cb 31**

Motor type	IMfinity® three-phase 4-pole motors							 kg
	AC	HJ	J	LB	LJ	I	II	
LSES 71 M	140	109	87	199,5	37	43,5	43,5	7,3
LSES 71 LR	140	109	87	247	41	43,5	43,5	8,3
LSES 80 LG	190	135	87	288	67,5	43,5	43,5	14,1
LSES 90 SL	190	135	87	290	71	43,5	43,5	16,2
LSES 90 LU	190	135	87	321,5	71	43,5	43,5	20,4
LSES 100 L	200	140	87	335,5	72	43,5	43,5	23
LSES 100 LR	200	140	87	354,5	72	43,5	43,5	25,8
LSES 100 LG	235	149	87	350,5	71	43,5	43,5	31

Motor type	Brake type	IMfinity® three-phase 4-pole motors and brak							 kg
		AC	HJ	J	LB	LJ	I	II	
LS 71 M	FFB 1	140	130	160	299,5	25,5	55	55	11,3
LS 71 L	FFB 1	140	130	160	305,5	25,5	55	55	11,3
LS 80 L	FFB 1	170	141	160	347	49,5	55	55	13,9
LSES 80 LG	FFB 1	190	151	160	430	55,5	55	55	18
LS 90 SL	FFB 2	190	151	160	434,5	59	55	55	18,2
LSES 90 SL	FFB 2	190	151	160	434,5	59	55	55	22,4
LS 90 L	FFB 2	190	151	160	434,5	59	55	55	21
LSES 90 LU	FFB 2	190	151	160	434,5	59	55	55	26,6
LS 100 L	FFB 2	200	156	160	482,5	60	55	55	29,6
LSES 100 L	FFB 2	200	156	160	482,5	60	55	55	29,6
LSES 100 LR	FFB 2	200	156	160	482,5	60	55	55	32
LSES 100 LG	FFB 3	235	165	160	458,5	59	55	55	37,6

Dimensions in millimetres

**Tapped form BT**

 Cb: 18.2 kg  
+ Motor

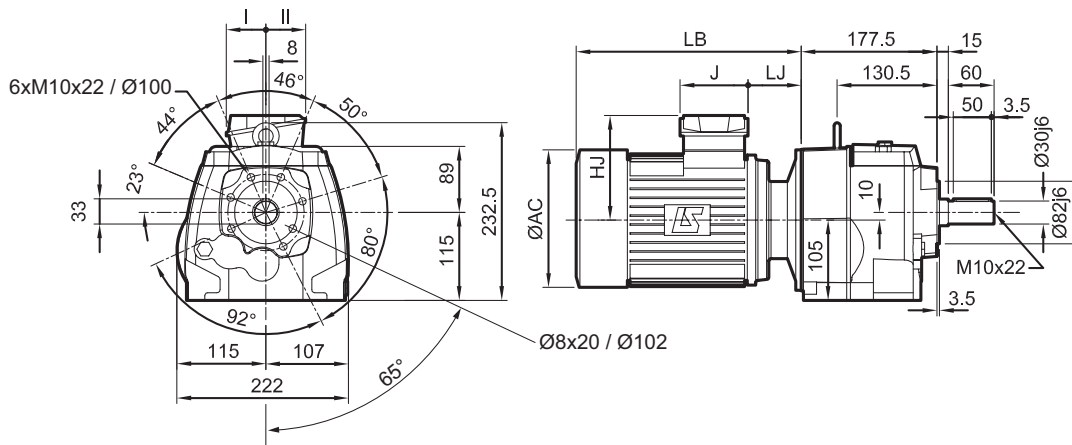

**Flange BD1**

 Cb: 18.7 kg  
+ Motor

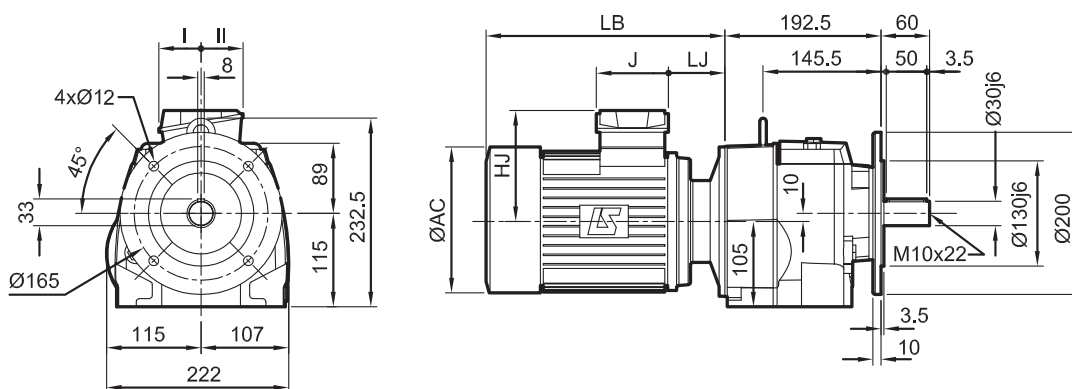

**Flange BD2**

 Cb: 18.6 kg  
+ Motor

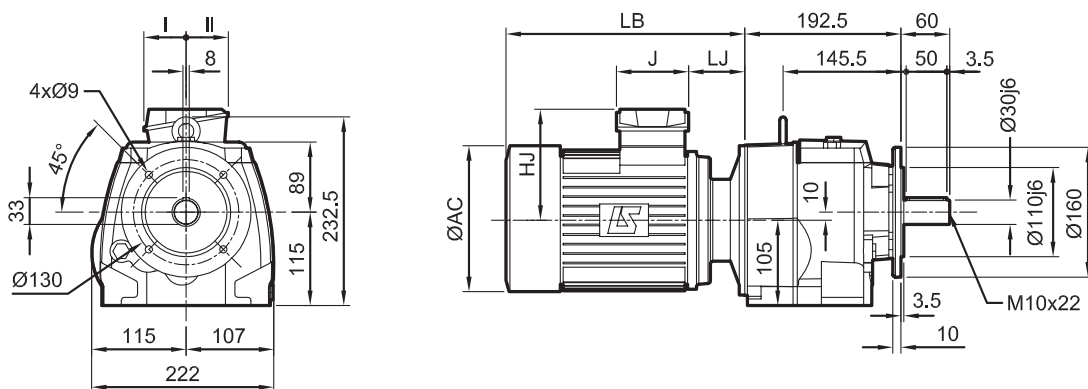

Dimensions

**Cb 3233 - Built-in mounting MI**

Dimensions in millimetres

**Feet S**

 Cb: 18.5 kg  
+ Motor

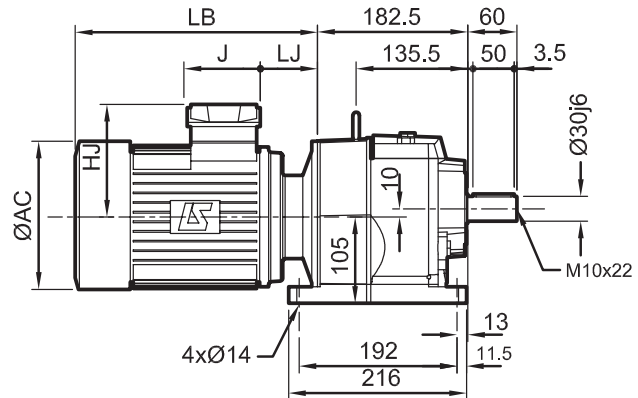
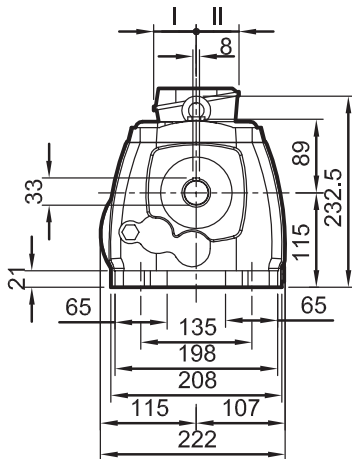

**Standard flange BS**

 Cb: 18.8 kg  
+ Motor

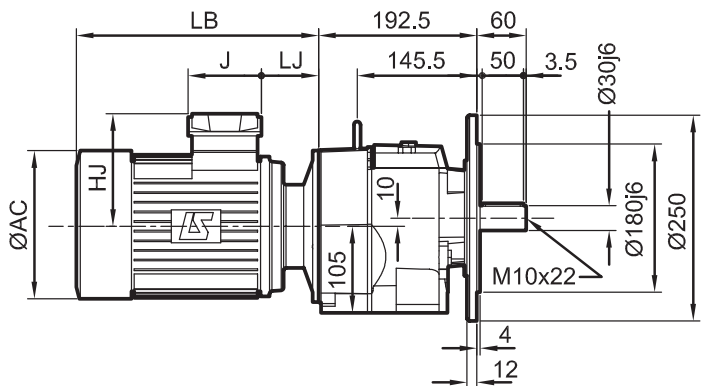
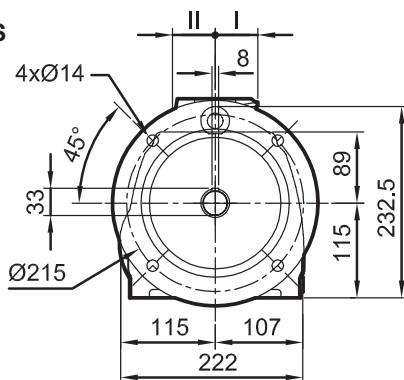

**Cb 32**

Motor type	IMfinity® three-phase 4-pole motors							kg
	AC	HJ	J	LB	LJ	I	II	
LSES 71 M	140	109	87	199,5	37	43,5	43,5	7,3
LSES 71 L	140	109	87	247	41	43,5	43,5	8,3
LSES 80 LG	190	135	87	288	67,5	43,5	43,5	14,1
LSES 90 SL	190	135	87	290	71	43,5	43,5	16,2
LSES 90 LU	190	135	87	321,5	71	43,5	43,5	20,4
LSES 100 L	200	140	87	335,5	72	43,5	43,5	22,6
LSES 100 LR	200	140	87	354,5	72	43,5	43,5	25,8
LSES 100 LG	235	149	87	350,5	71	43,5	43,5	31
LSES 112 MU	235	149	87	368,5	71	43	43	37
LSES 132 SM	272	190	126	437	69	63	63	52

Motor type	Brake type	IMfinity® three-phase 4-pole motors and brake							kg
		AC	HJ	J	LB	LJ	I	II	
LS 71 M	FFB 1	140	130	160	295,5	21,5	55	55	10,3
LS 71 L	FFB 1	140	130	160	295,5	21,5	55	55	11,3
LS 80 L	FFB 1	170	141	160	347	49,5	55	55	13,9
LSES 80 LG	FFB 1	190	151	160	430	55,5	55	55	17,1
LS 90 SL	FFB 2	190	151	160	434,5	59	55	55	18,2
LSES 90 SL	FFB 2	190	151	160	434,5	59	55	55	22,4
LS 90 L	FFB 2	190	151	160	434,5	59	55	55	21
LSES 90 LU	FFB 2	190	151	160	434,5	59	55	55	26,6
LS 100 L	FFB 2	200	156	160	482,5	60	55	55	29,1
LSES 100 L	FFB 2	200	156	160	482,5	60	55	55	29,6
LSES 100 LR	FFB 2	200	156	160	482,5	60	55	55	32
LSES 100 LG	FFB 3	235	165	160	458,5	59	55	55	37,6
LS 112 MG	FFB 3	235	165	160	486	61,5	55	55	37,6
LSES 112 MU	FFB 3	235	165	160	483,5	59	55	55	40,9
LS 132 S	FFB 3	227	168	160	509	60,5	55	55	44,6
LSES 132 SM	FFB 4	272	186	160	648	77,5	55	55	66,5

Dimensions in millimetres

**Tapped form BT**

 Cb: 29 kg  
+ Motor

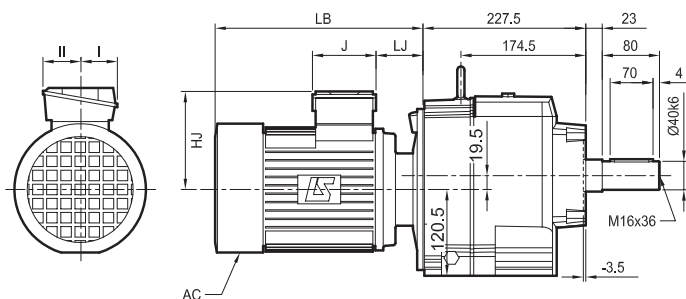
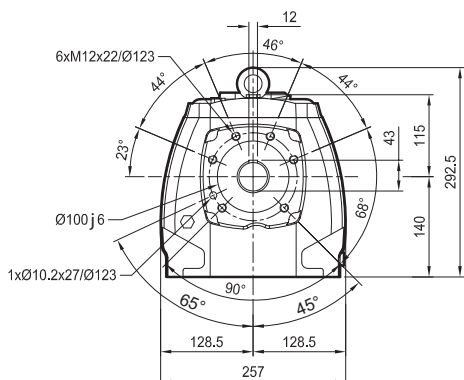

**Flange BD1**

 Cb: 33 kg  
+ Motor

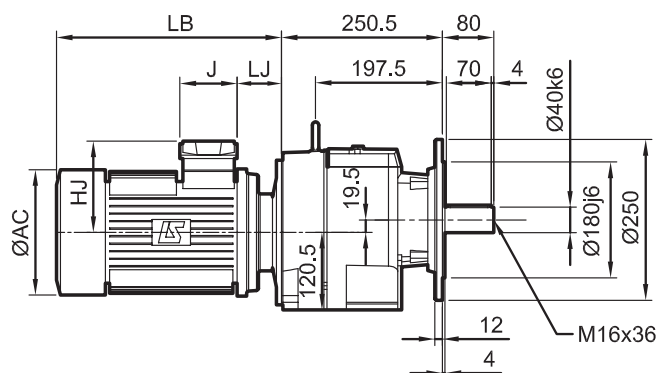
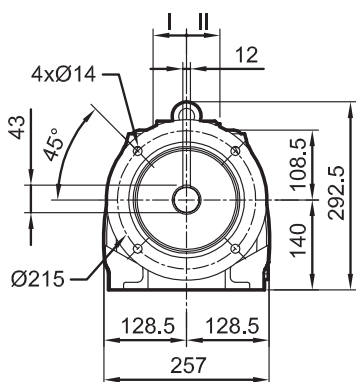

**Flange BD2**

 Cb: 32.5 kg  
+ Motor

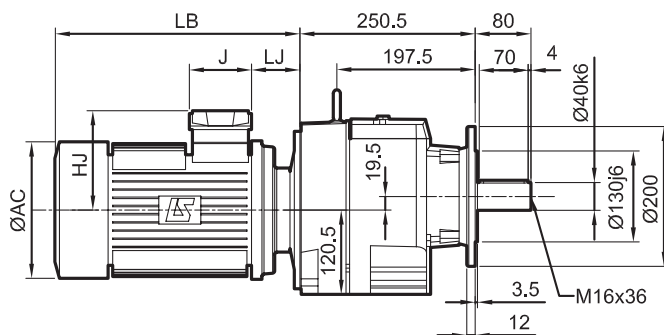
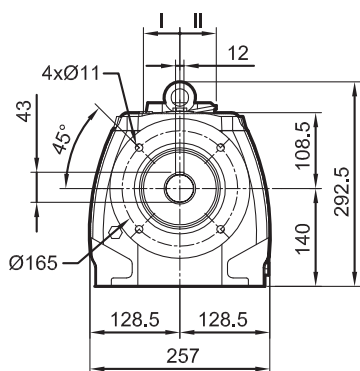

**Flange BR**

 Cb: 44 kg  
+ Motor

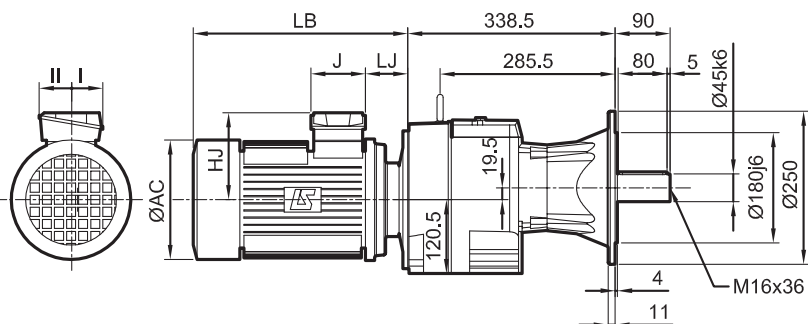
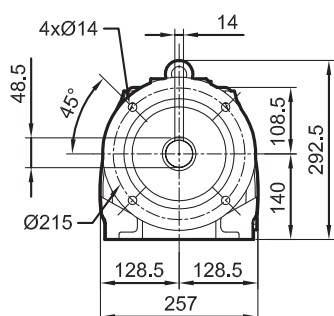

Dimensions  
Cb 3333 - Built-in mounting MI

Dimensions in millimetres

Feet S

 Cb: 30 kg  
+ Motor

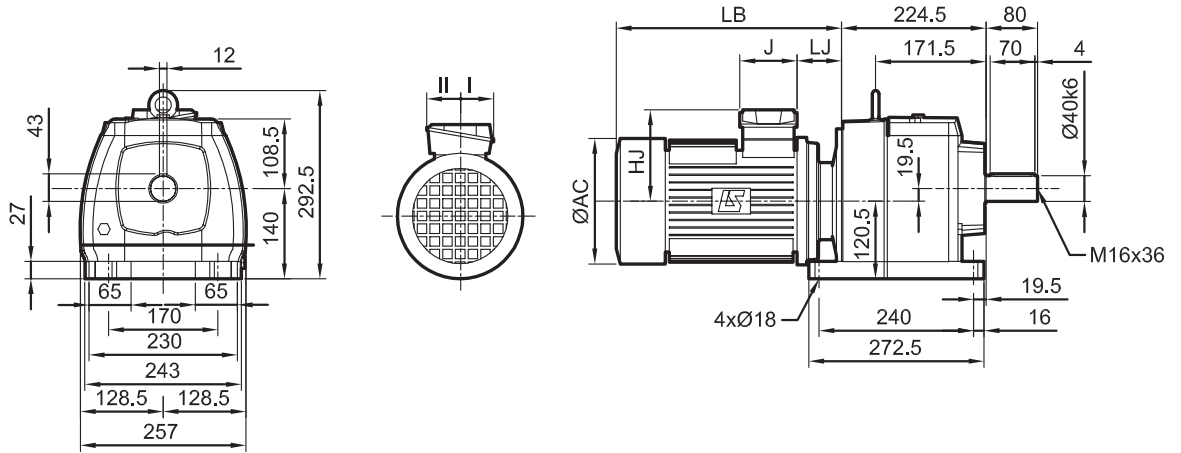

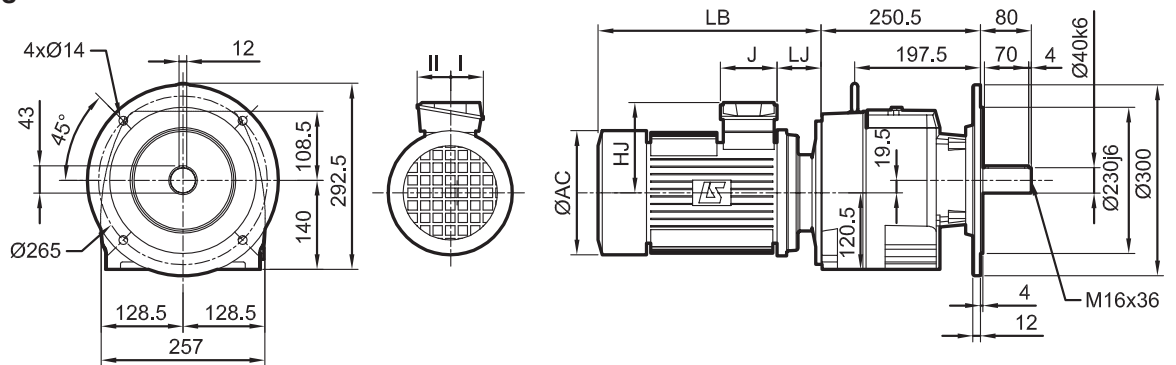

Standard flange BS

 Cb: 34 kg  
+ Motor



Cb 33

Motor type	IMfinity® three-phase 4-pole motors							 kg
	AC	HJ	J	LB	LJ	I	II	
LSES 71 M	140	109	87	195,5	33	43	43	7,3
LSES 71 LR	140	109	87	243	37	43	43	9
LSES 80 LG	190	135	87	284	63,5	43	43	15
LSES 90 SL	190	135	87	286	67	43	43	16,2
LSES 90 LU	190	135	87	317,5	67	43	43	20,4
LSES 100 L	200	140	87	331,5	68	43	43	23
LSES 100 LR	200	140	87	331,5	68	43	43	25,8
LSES 100 LG	235	149	87	346,5	67	43	43	31
LSES 112 MU	235	149	87	364,5	67	43	43	37
LSES 132 SM	272	190	126	433	65	63	63	52
LSES 132 MU	272	190	126	460	65	63	63	62,6

Motor type	Brake type	IMfinity® three-phase 4-pole motors and brake							 kg
		AC	HJ	J	LB	LJ	I	II	
LS 71 M	FFB 1	140	130	160	295,5	21,5	55	55	10,3
LS 71 L	FFB 1	140	130	160	295,5	21,5	55	55	11,3
LS 80 L	FFB 1	170	141	160	343	45,5	55	55	13,9
LSES 80 LG	FFB 1	190	151	160	426	51,5	55	55	18
LS 90 SL	FFB 2	190	151	160	430,5	55	55	55	18,2
LSES 90 SL	FFB 2	190	151	160	430,5	55	55	55	22,4
LS 90 L	FFB 2	190	151	160	430,5	55	55	55	21
LSES 90 LU	FFB 2	190	151	160	430,5	55	55	55	26,6
LS 100 L	FFB 2	200	156	160	478,5	56	55	55	29,1
LSES 100 L	FFB 2	200	156	160	478,5	56	55	55	29,6
LSES 100 LR	FFB 2	200	156	160	478,5	56	55	55	32
LSES 100 LG	FFB 3	235	165	160	454,5	55	55	55	37,6
LS 112 MG	FFB 3	235	165	160	448	28,5	55	55	37,6
LSES 112 MU	FFB 3	235	165	160	479,5	55	55	55	40,9
LS 132 S	FFB 3	227	168	160	505	56,5	55	55	44,6
LSES 132 SM	FFB 4	272	186	160	644	73,5	55	55	66,5
LS 132 M	FFB 4	272	186	160	644	73,5	55	55	67,4
LSES 132 MU	FFB 4	272	186	160	644	73,5	55	55	77,1

Dimensions

**Cb 3433 - Built-in mounting MI**

Dimensions in millimetres

**Tapped form BT**



Cb: 48 kg  
+ Motor

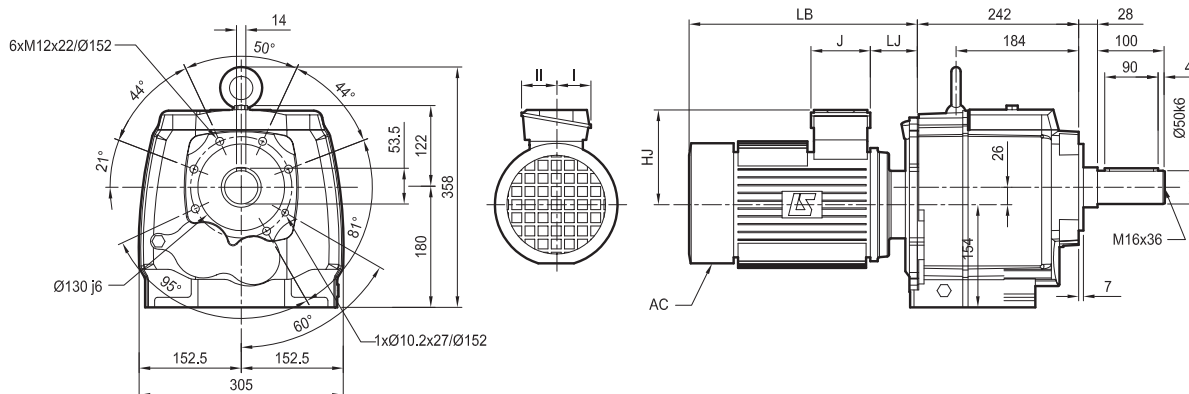

**Flange BD1**



Cb: 55 kg  
+ Motor

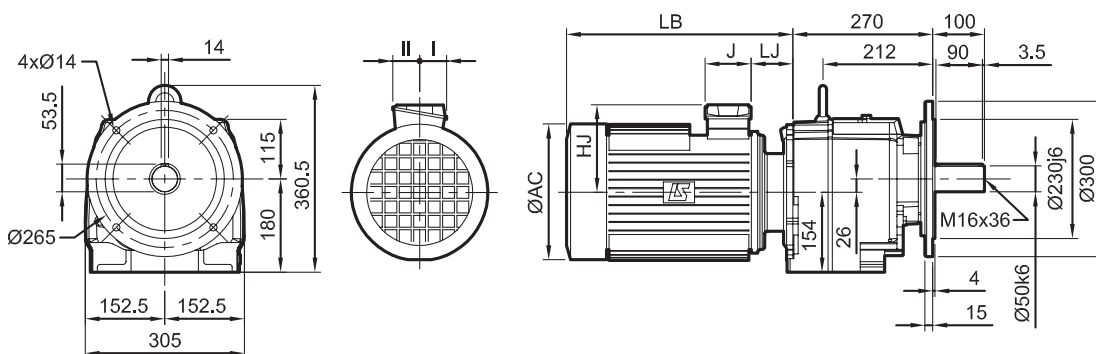

**Flange BD2**



Cb: 54 kg  
+ Motor

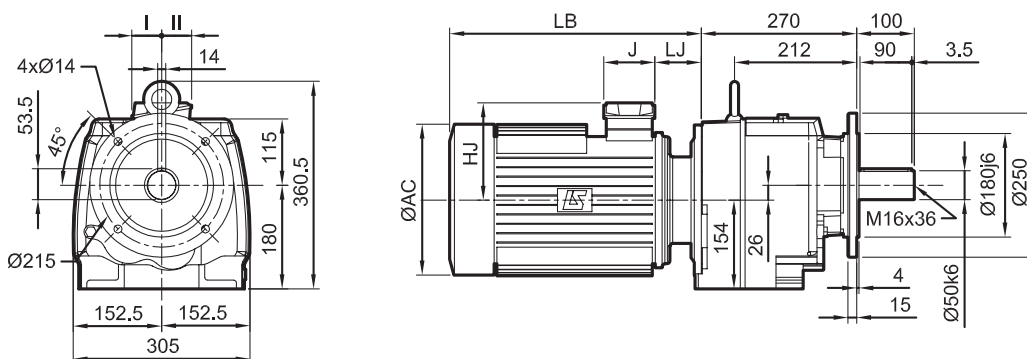

**Flange BR**



Cb: 72 kg  
+ Motor

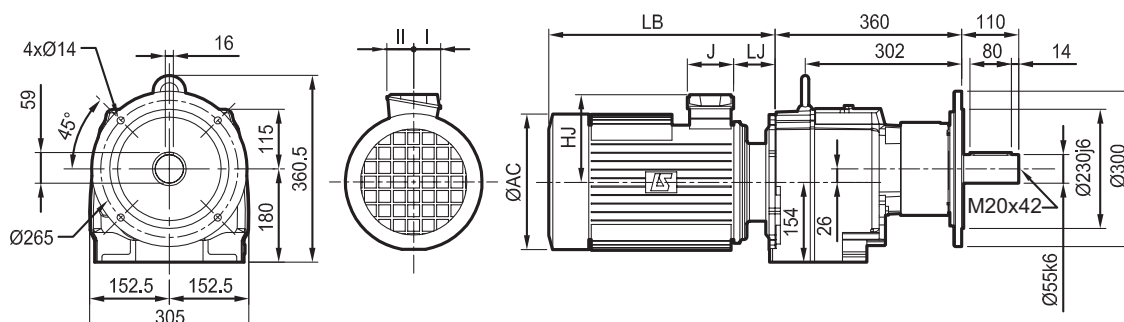



Dimensions

Cb 3433 - Built-in mounting MI

Dimensions in millimetres

Feet S

Cb: 50 kg  
+ Motor

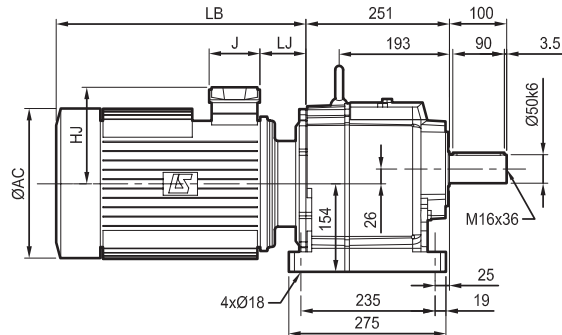
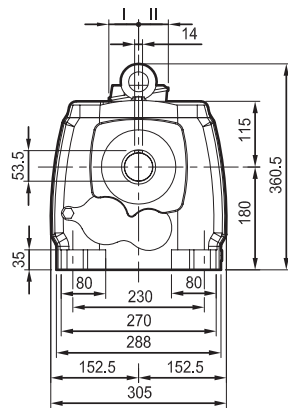

Standard flange BS

Cb: 56 kg  
+ Motor

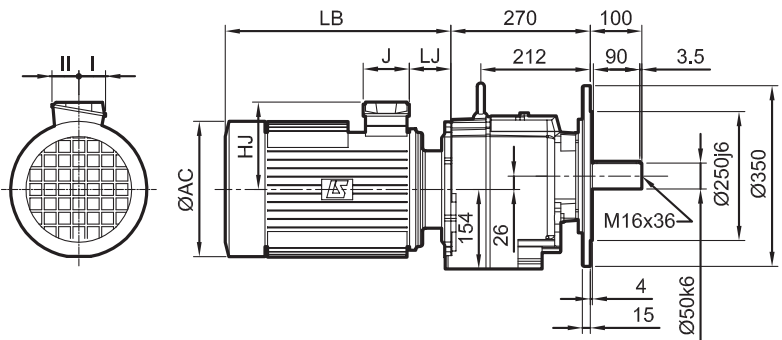
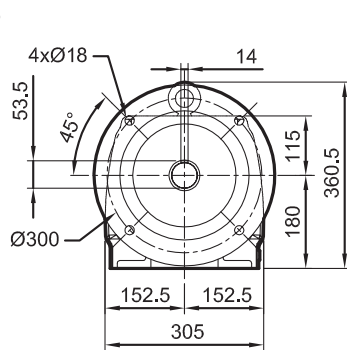

Cb 34

Motor type	IMfinity® three-phase 4-pole motors							kg
	AC	HJ	J	LB	LJ	I	II	
LSES 80 LG	190	135	87	288,5	68	43	43	15
LSES 90 SL	190	135	87	286	67	43	43	16,2
LSES 90 LU	190	135	87	317,5	67	43	43	20,4
LSES 100 L	200	140	87	331,5	68	43	43	23
LSES 100 LR	200	140	87	350,5	68	43	43	25,8
LSES 100 LG	235	149	87	346,5	67	43	43	31
LSES 112 MU	235	149	87	364,5	67	43	43	37
LSES 132 SM	272	190	126	437	69	63	63	52
LSES 132 MU	272	190	126	464	69	63	63	62,6
LSES 160 MR	272	190	126	506	69,5	63	63	78
LSES 160 M	312	235	135	508	55,8	88	64	93
LSES 160 LUR	312	235	135	523	55,8	88	64	100
LSES 180 M	350	256	186	565	76,5	112	98	130
LSES 180 LUR	350	256	186	627	76,5	112	98	155

Motor type	Brake type	IMfinity® three-phase 4-pole motors and brake <sup>1</sup>							kg
		AC	HJ	J	LB	LJ	I	II	
LS 80 L	FFB 1	170	141	160	347,5	50	55	55	13,9
LSES 80 LG	FFB 1	190	151	160	430,5	56	55	55	18
LS 90 SL	FFB 2	190	151	160	430,5	55	55	55	18,2
LSES 90 SL	FFB 2	190	151	160	430,5	55	55	55	22,4
LS 90 L	FFB 2	190	151	160	430,5	55	55	55	21
LSES 90 LU	FFB 2	190	151	160	430,5	55	55	55	26,6
LS 100 L	FFB 2	200	156	160	478,5	56	55	55	29,1
LSES 100 L	FFB 2	200	156	160	478,5	55	55	55	29,6
LSES 100 LR	FFB 2	200	156	160	478,5	55	55	55	32
LSES 100 LG	FFB 3	235	165	160	454,5	55	55	55	37,6
LS 112 MG	FFB 3	235	165	160	482	28,5	55	55	37,6
LSES 112 MU	FFB 3	235	165	160	479,5	55	55	55	40,9
LS 132 S	FFB 3	227	168	160	509	60,5	55	55	44,6
LSES 132 SM	FFB 4	272	186	160	648	77,5	55	55	66,5
LS 132 M	FFB 4	272	186	160	648	77,5	55	55	67,4
LSES 132 MU	FFB 4	272	186	160	648	77,5	55	55	77,1
LSES 160 MR	FFB 4	272	186	160	683	77	55	55	92,3
LS 160 MP	FFB 5	272	186	160	682	77	55	55	83,2
LS 160 LR	FFB 5	272	186	160	682	77	55	55	96,1
LSES 160 M	FFB 5	312	248	186	695	59	112	98	110
LSES 160 LUR	FFB 5	312	248	186	690	59	112	98	117
LS 180 MT	FFB 5	312	248	186	695	59	112	98	117
LS 180 LR	FCPL 54HID	312	235	134	696	57	92	63	152

<sup>1</sup> except brake motor in italics

#### Cb 3533 - Built-in mounting MI

Dimensions in millimetres

##### Tapped form BT



Cb: 86 kg  
+ Motor

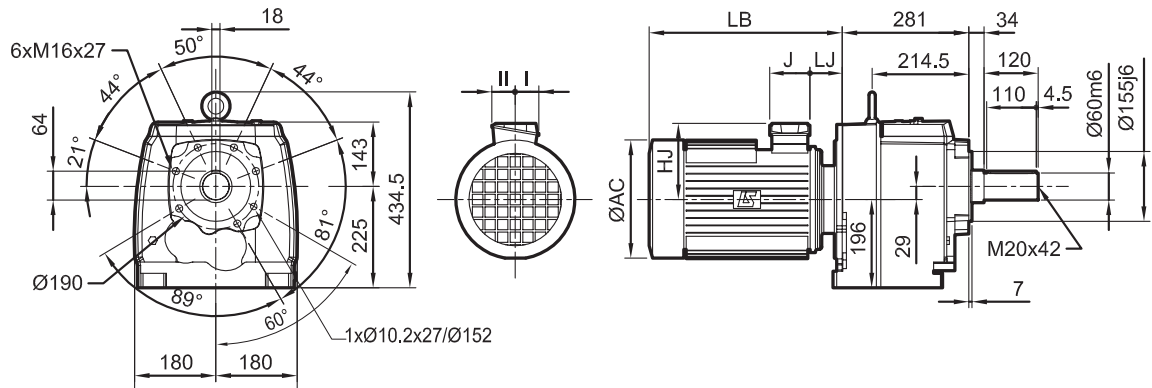

##### Flange BD1



Cb: 96 kg  
+ Motor

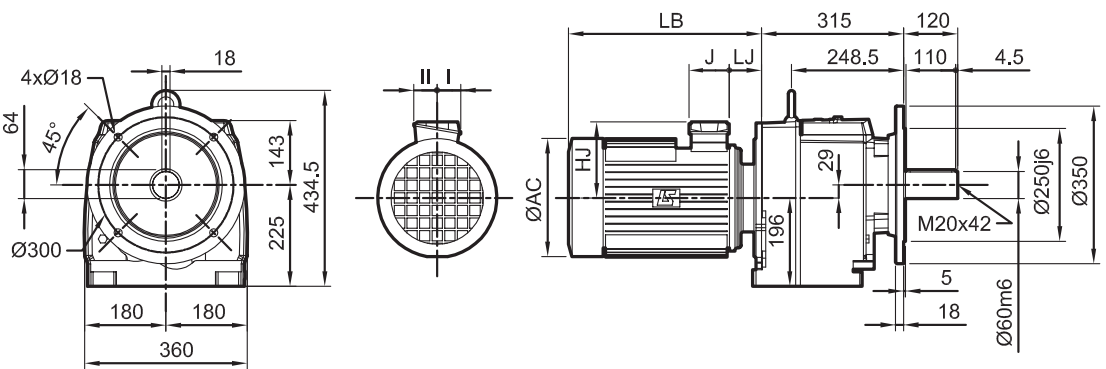

##### Flange BD2



Cb: 90 kg  
+ Motor

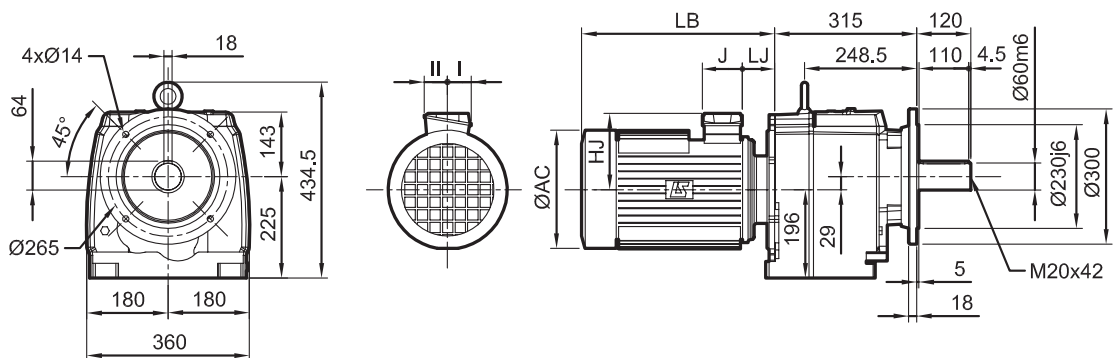

##### Flange BR



Cb: 130 kg  
+ Motor

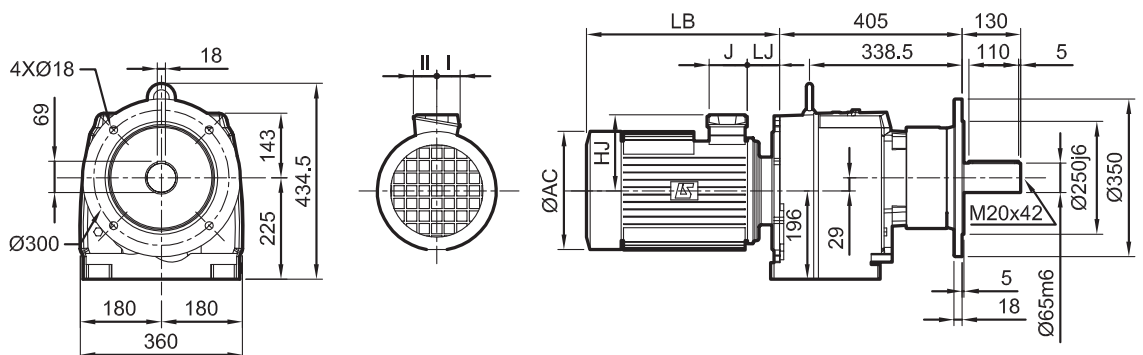

Dimensions

Cb 3533 - Built-in mounting MI

Dimensions in millimetres

Feet S

 Cb: 90 kg  
+ Mot

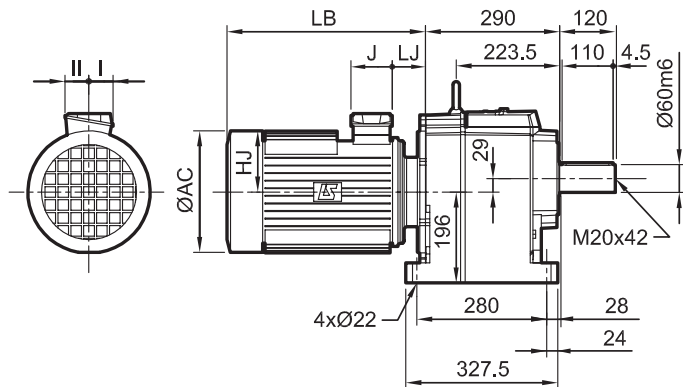
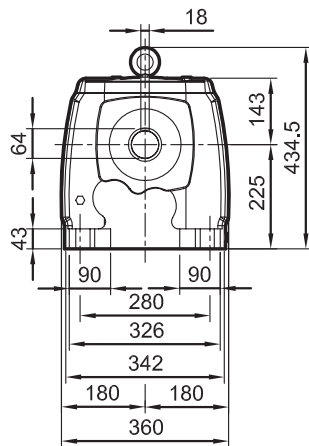

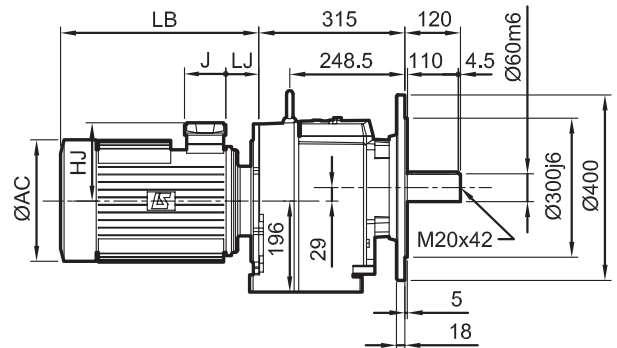
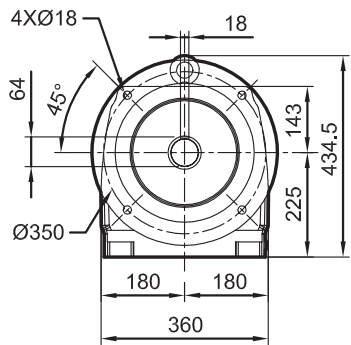

Standard flange BS

 Cb: 97 kg  
+ Mot



Cb 35

Motor type	IMfinity® three-phase 4-pole motors							 kg
	AC	HJ	J	LB	LJ	I	II	
LSES 90 SL	190	135	87	281	62	43	43	16,2
LSES 90 LU	190	135	87	312,5	62	43	43	20,4
LSES 100 L	200	140	87	326,5	63	43	43	22,6
LSES 100 LR	200	140	87	345,5	63	43	43	25,8
LSES 100 LG	235	149	87	341,5	62	43	43	31
LSES 112 MU	235	149	87	359,5	62	43	43	37
LSES 132 SM	272	190	126	428	60	63	63	52
LSES 132 MR	272	190	126	455	60	63	63	62,6
LSES 160 MR	272	190	126	498	61,5	63	63	77,8
LSES 160 M	312	235	135	499	46,8	88	64	93
LSES 160 LUR	312	235	135	514	46,8	88	64	100
LSES 180 M	350	256	186	556	67,5	112	98	130
LSES 180 LUR	350	256	186	618	67,5	112	98	155
LSES 200 LU	390	276	186	683	91	112	98	225

Motor type	Brake type	IMfinity® three-phase 4-pole motors and brake <sup>1</sup>							 kg
		AC	HJ	J	LB	LJ	I	II	
LS 90 SL	FFB 2	190	151	160	425,5	50	55	55	18,2
LSES 90 SL	FFB 2	190	151	160	425,5	50	55	55	22,4
LS 90 L	FFB 2	190	151	160	425,5	50	55	55	21
LSES 90 LU	FFB 2	190	151	160	425,5	50	55	55	26,6
LS 100 L	FFB 2	200	156	160	473,5	51	55	55	29,1
LSES 100 L	FFB 2	200	156	160	473,5	50	55	55	29,6
LSES 100 LR	FFB 2	200	156	160	473,5	50	55	55	32
LSES 100 LG	FFB 3	235	165	160	449,5	50	55	55	37,6
LS 112 MG	FFB 3	235	165	160	477	52,5	55	55	37,6
LSES 112 MU	FFB 3	235	165	160	474,5	50	55	55	40,9
LS 132 S	FFB 3	227	168	160	500	51,5	55	55	44,6
LSES 132 SM	FFB 4	272	186	160	639	68,5	55	55	66,5
LS 132 M	FFB 4	272	186	160	639	68,5	55	55	67,4
LSES 132 MU	FFB 4	272	186	160	639	68,5	55	55	77,1
LSES 160 MR	FFB 4	272	186	160	674	69,5	55	55	92,3
LS 160 MP	FFB 5	272	186	160	674	69,5	55	55	82,9
LS 160 LR	FFB 5	272	186	160	674	69,5	55	55	96,1
LSES 160 M	FFB 5	312	248	186	686	50	112	98	110
LSES 160 LUR	FFB 5	312	248	186	686	50	112	98	117
LS 180 MT	FFB 5	312	248	186	686	50	112	98	117
LS 180 LR	FCPL 54H1D	312	235	134	687	48	92	63	152
LS 200 LT	FCPL 54H1D <sup>2</sup>	350	263	134	783	95	92	63	200

<sup>1</sup> except brake motor in italics

<sup>2</sup> with CDF board

Dimensions in millimetres

**Tapped form BT**



Cb: 162 kg  
+ Motor

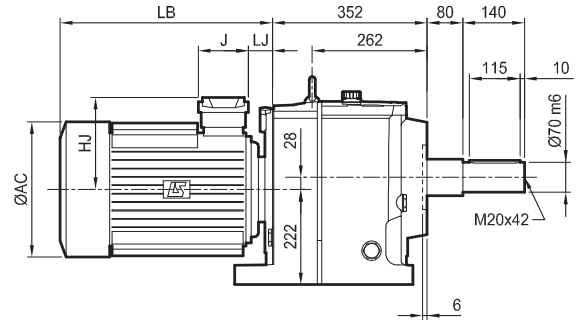
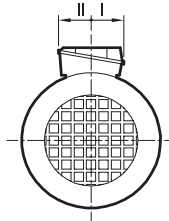
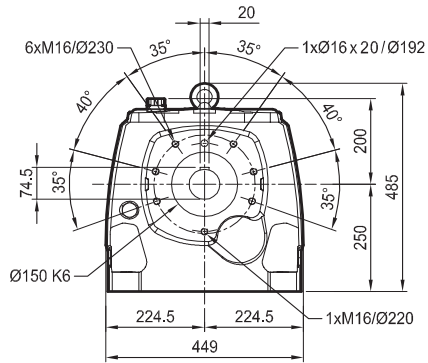

**Flange BD1**



Cb: 190 kg  
+ Motor

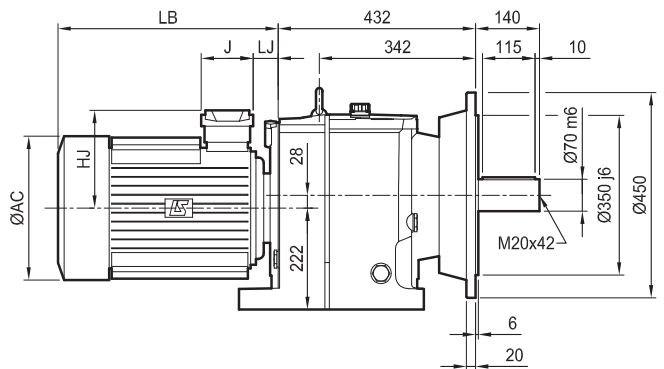
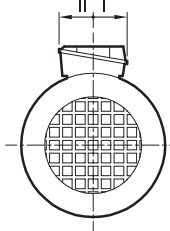
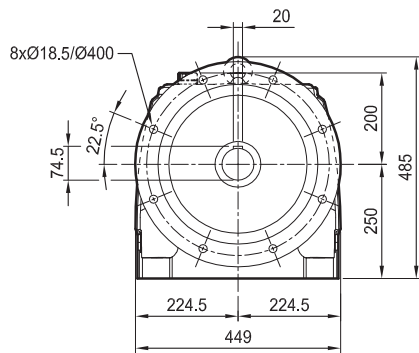

Dimensions

Cb 3633 - Built-in mounting MI

Feet S

 Cb: 162 kg  
+ Motor

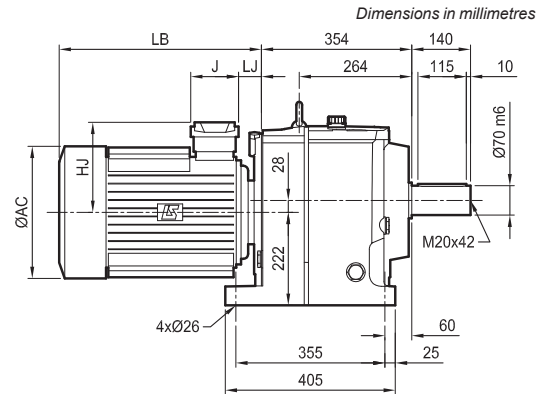
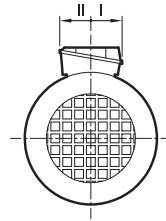
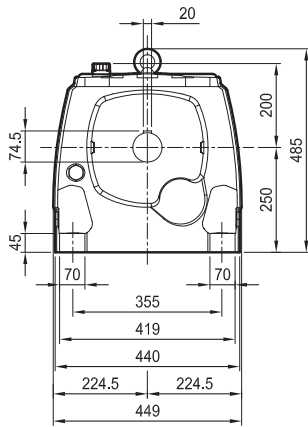

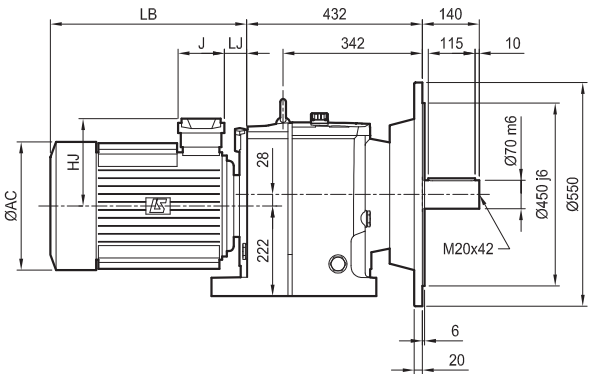
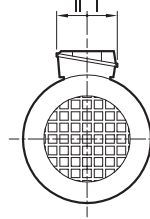
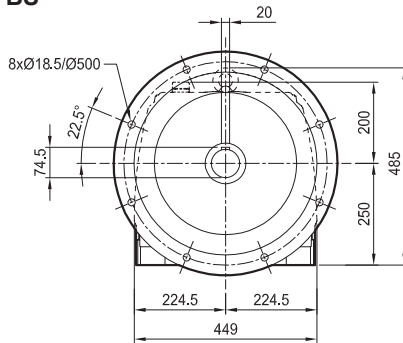

Standard flange BS

 Cb: 196 kg  
+ Motor



Cb 36

Motor type	IMfinity® three-phase 4-pole motors							 kg
	AC	HJ	J	LB	LJ	I	II	
LSES 90 SL	190	135	87	272	53	43	43	16,2
LSES 90 LU	190	135	87	303,5	53	43	43	20,4
LSES 100 L	200	140	87	317,5	54	43	43	22,6
LSES 100 LR	200	140	87	336,5	54	43	43	25,8
LSES 100 LG	235	149	87	332,5	53	43	43	31
LSES 112 MU	235	149	87	350,5	53	43	43	37
LSES 132 SM	272	190	126	419	51	63	63	52
LSES 132 MU	272	190	126	446	51	63	63	62,6
LSES 160 MR	272	190	126	489	52,5	63	63	77,8
LSES 160 M	312	235	135	490	37,8	88	64	93
LSES 160 LUR	312	235	135	505	37,8	88	64	100
LSES 180 M	350	256	186	547	58,8	112	98	130
LSES 180 LUR	350	256	186	609	58,8	112	98	155
LSES 200 LU	390	276	186	674	82	112	98	225
LSES 225 SR	390	310	231	675	59,5	119	142	236
LSES 225 MG	479	405	292	825	83,5	151	181	318
LSES 250 ME	479	405	292	825	83,5	151	181	350

Motor type	Brake type	IMfinity® three-phase 4-pole motors and brake <sup>1</sup>							 kg
		AC	HJ	J	LB	LJ	I	II	
LS 90 SL	FFB 2	190	151	160	416,5	41	55	55	18,2
LSES 90 SL	FFB 2	190	151	160	416,5	41	55	55	22,4
LS 90 L	FFB 2	190	151	160	416,5	41	55	55	21
LSES 90 LU	FFB 2	190	151	160	416,5	41	55	55	26,6
LS 100 L	FFB 2	200	156	160	464,5	41	55	55	29,1
LSES 100 L	FFB 2	200	156	160	464,5	41	55	55	29,6
LSES 100 LR	FFB 2	200	156	160	464,5	41	55	55	32
LSES 100 LG	FFB 3	235	165	160	440,5	41	55	55	37,6
LS 112 MG	FFB 3	235	165	160	468	43,5	55	55	37,6
LSES 112 MU	FFB 3	235	165	160	465,5	41	55	55	40,9
LS 132 S	FFB 3	227	168	160	491	43	55	55	44,6
LSES 132 SM	FFB 4	272	186	160	630	60	55	55	66,5
LS 132 M	FFB 4	272	186	160	630	60	55	55	67,4
LSES 132 MU	FFB 4	272	186	160	665	61,5	55	55	77,1
LSES 160 MR	FFB 4	272	186	160	664	60,5	55	55	92,3
LS 160 MP	FFB 5	272	186	160	664	60,5	55	55	82,9
LS 160 LR	FFB 5	272	186	160	664	60,5	55	55	96
LSES 160 M	FFB 5	312	248	186	667	46,8	112	98	110
LSES 160 LUR	FFB 5	312	248	186	672	41	112	98	117
LS 180 MT	FFB 5	312	248	186	677	41	112	98	117
LS 180 LR	<i>FCPL 54H1D</i>	312	235	134	678	39	92	63	152
LS 200 LT	<i>FCPL 54H1D<sup>2</sup></i>	350	263	134	774	86	92	63	200
LS 225 ST	<i>FCPL 54H1D<sup>2</sup></i>	390	283	134	836	109,5	92	63	242
LS 225 MR	<i>FCPL 54H1D<sup>2</sup></i>	390	283	134	878	109,5	92	63	274

<sup>1</sup> except brake motor in italics

<sup>2</sup> with CDF board

Dimensions

**Cb 3733 - Built-in mounting MI**

Dimensions in millimetres

**Tapped form BT**



Cb: 192 kg  
+ Motor

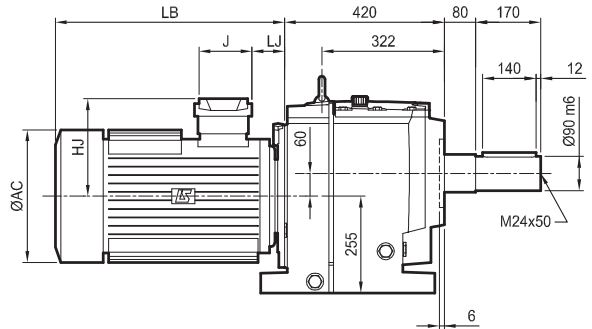
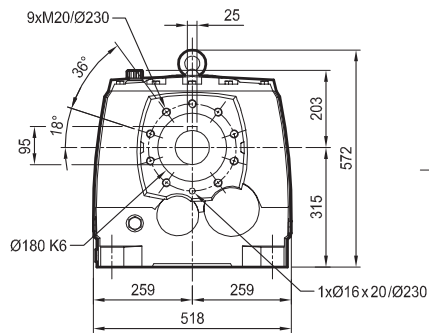

**Flange BD1**



Cb: 222 kg  
+ Motor

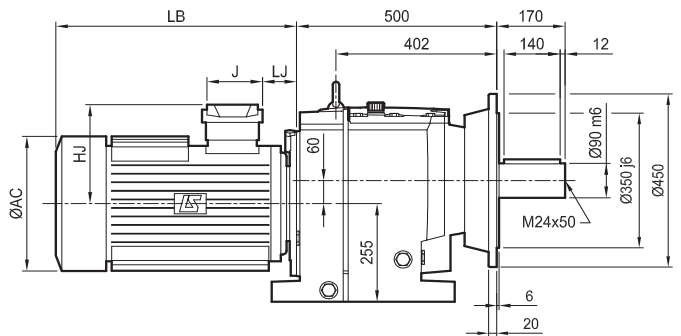
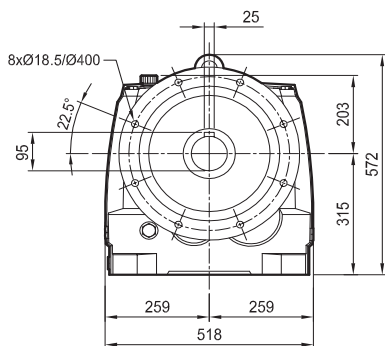

Dimensions

Cb 3733 - Built-in mounting MI

Feet S

 Cb: 192 kg + Motor

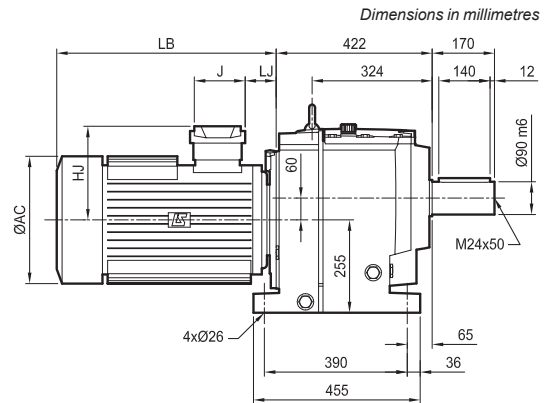
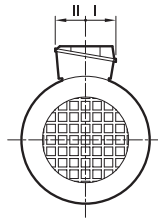
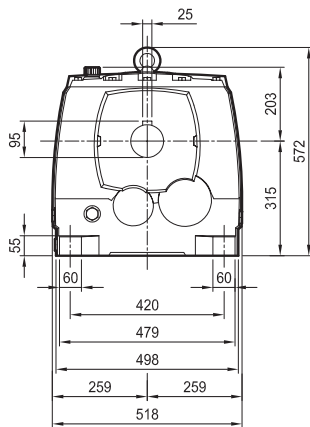

Standard flange BS

 Cb: 228 kg + Motor

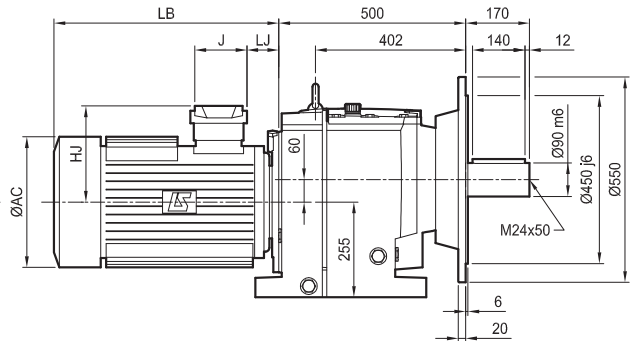
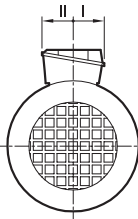
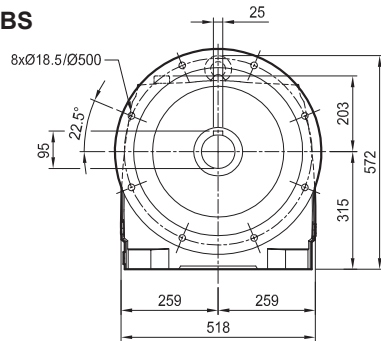

Cb 37

Motor type	IMfinity® three-phase 4-pole motors							kg
	AC	HJ	J	LB	LJ	I	II	
LSES 90 SL	190	135	87	272	53	43	43	16,2
LSES 90 LU	190	135	87	303,5	53	43	43	20,4
LSES 100 L	200	140	87	317,5	54	43	43	22,6
LSES 100 LR	200	140	87	336,5	54	43	43	25,8
LSES 100 LG	235	149	87	332,5	53	43	43	31
LSES 112 MU	235	149	87	350,5	53	43	43	37
LSES 132 SM	272	190	126	419	51	63	63	52
LSES 132 MU	272	190	126	446	51	63	63	62,6
LSES 160 MR	272	190	126	489	52,5	63	63	77,8
LSES 160 M	312	235	135	490	37,8	88	64	93
LSES 160 LUR	312	235	135	505	37,8	88	64	100
LSES 180 M	350	256	186	547	58,8	112	98	130
LSES 180 LUR	350	256	186	609	58,8	112	98	155
LSES 200 LU	390	276	186	674	82	112	98	225
LSES 225 SR	390	310	231	674,5	59,5	119	142	236
LSES 225 MG	479	405	292	825	83,5	151	181	318
LSES 250 ME	479	405	292	825	83,5	151	181	350
LSES 280 SD	479	405	292	885	83,5	151	181	428
LSES 280 MD	479	405	292	885	83,5	151	181	470

Motor type	Brake type	IMfinity® three-phase 4-pole motors and brake <sup>1</sup>							kg
		AC	HJ	J	LB	LJ	I	II	
LS 90 SL	FFB 2	190	151	160	416,5	41	55	55	18,2
LSES 90 SL	FFB 2	190	151	160	416,5	41	55	55	22,4
LS 90 L	FFB 2	190	151	160	416,5	41	55	55	21
LSES 90 LU	FFB 2	190	151	160	416,5	41	55	55	26,6
LS 100 L	FFB 2	200	156	160	464,5	41	55	55	29,1
LSES 100 L	FFB 2	200	156	160	464,5	41	55	55	29,6
LSES 100 LR	FFB 2	200	156	160	464,5	41	55	55	32
LSES 100 LG	FFB 3	235	165	160	440,5	41	55	55	37,6
LS 112 MG	FFB 3	235	165	160	468	43,5	55	55	37,6
LSES 112 MU	FFB 3	235	165	160	465,5	41	55	55	40,9
LS 132 S	FFB 3	227	168	160	491	43	55	55	44,6
LSES 132 SM	FFB 4	272	186	160	630	60	55	55	66,5
LS 132 M	FFB 4	272	186	160	630	60	55	55	67,4
LSES 132 MU	FFB 4	272	186	160	665	61,5	55	55	77,1
LSES 160 MR	FFB 4	272	186	160	664	60,5	55	55	92,3
LS 160 MP	FFB 5	272	186	160	664	60,5	55	55	82,9
LS 160 LR	FFB 5	272	186	160	664	60,5	55	55	96
LSES 160 M	FFB 5	312	248	186	667	46,8	112	98	110
LSES 160 LUR	FFB 5	312	248	186	672	41	112	98	117
LS 180 MT	FFB 5	312	248	186	677	41	112	98	117
LS 180 LR	<i>FCPL 54H1D</i>	312	235	134	678	39	92	63	152
LS 200 LT	<i>FCPL 54H1D<sup>2</sup></i>	350	263	134	774	86	92	63	200
LS 225 ST	<i>FCPL 54H1D<sup>2</sup></i>	390	283	134	836	109,5	92	63	242

<sup>1</sup> except brake motor in italics  
<sup>2</sup> with CDF board

Dimensions

Cb 3833 - Built-in mounting MI

Dimensions in millimetres

Tapped form BT



Cb: 290 kg + Motor

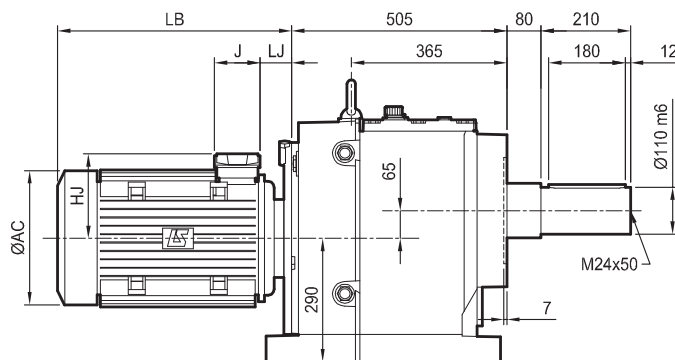
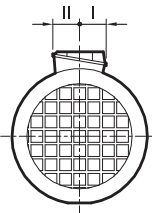
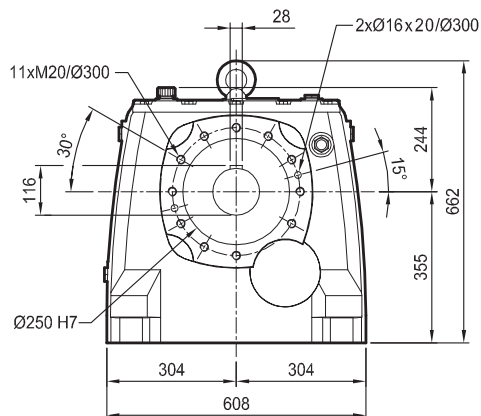

Flange BD1



Cb: 328 kg + Motor

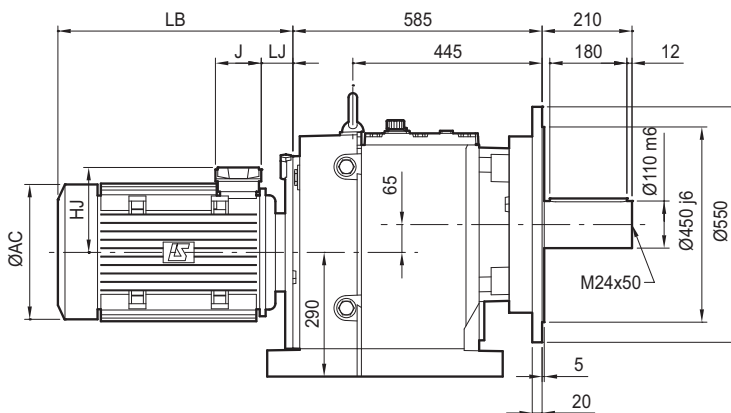
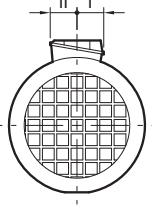
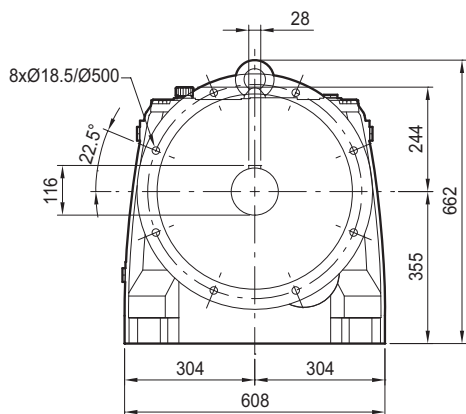



Dimensions

Cb 3833 - Built-in mounting MI

Dimensions in millimetres

Feet S

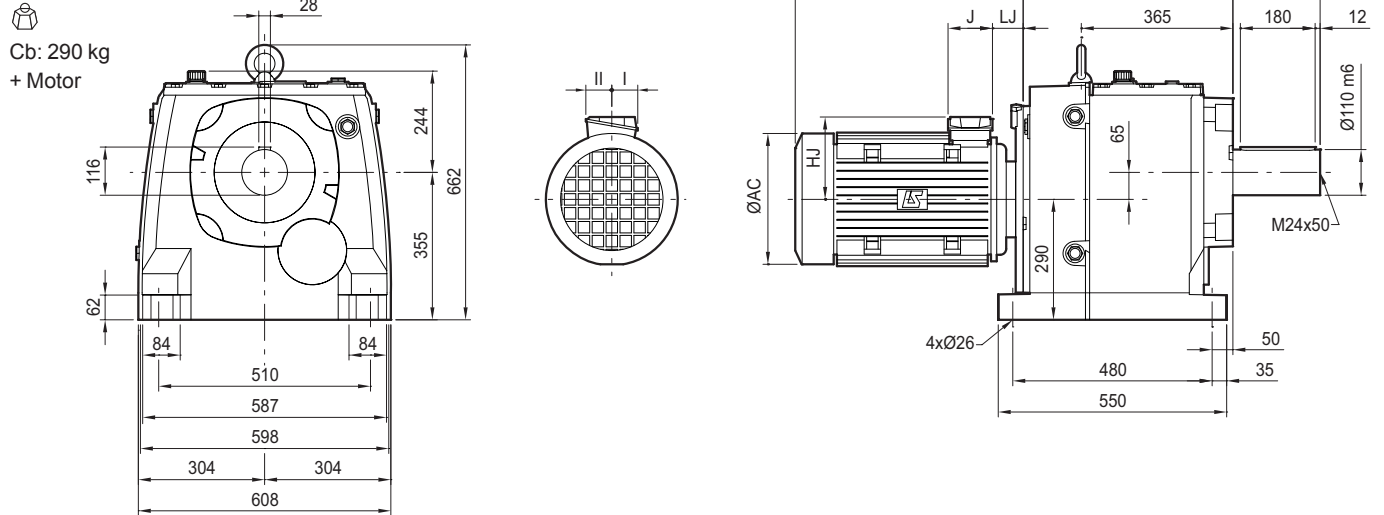

Standard flange BS

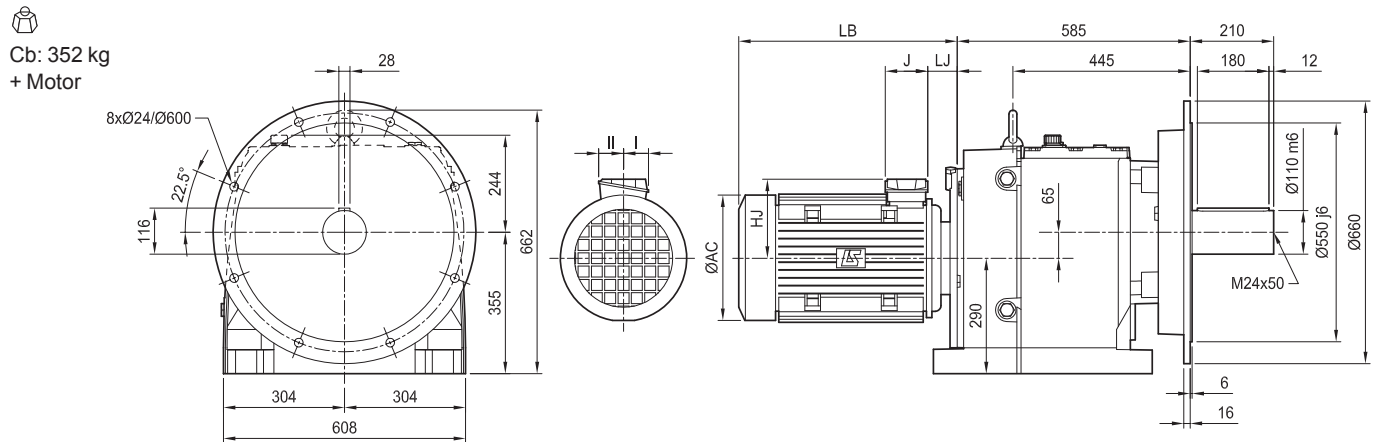

Cb 38

Motor type	IMfinity® three-phase 4-pole motors								kg	Motor type	Brake type	IMfinity® three-phase 4-pole motors and brake <sup>1</sup>								kg
	AC	HJ	J	LB	LJ	I	II	AC				HJ	J	LB	LJ	I	II			
LSES 132 MU	272	190	126	433	38	63	63	62,6	LS 132 M	FFB 4	265	186	160	617	46,5	55	55	67,4		
LSES 160 MR	272	190	126	476	40	63	63	77,8	LSES 132 MU	FFB 4	265	186	160	617	46,5	55	55	77,1		
LSES 160 M	312	235	135	477	27	92	63	93	LSES 160 MR	FFB 4	264	186	160	651	47,5	55	55	92,3		
LSES 160 LUR	312	235	135	492	26	92	63	100	LS 160 MP	FFB 5	264	186	160	651	47,5	55	55	82,9		
LSES 180 M	350	256	186	534	46	112	98	130	LS 160 LR	FFB 5	265	186	160	651	47,5	55	55	96,1		
LSES 180 LUR	350	256	186	596	46	112	98	155	LSES 160 M	FFB 5	312	248	186	665	28	112	98	110		
LSES 200 LU	390	276	186	662	69,5	112	98	225	LSES 160 LUR	FFB 5	312	248	186	659	28	112	98	117		
LSES 225 SR	390	310	231	662	46,5	119	142	236	LS 180 MT	FFB 5	312	248	186	665	28	112	98	117		
LSES 225 MG	479	405	292	812	70,5	151	181	318	LS 180 LR	FCPL 54H1D	312	235	134	665	26	92	63	152		
LSES 250 ME	479	405	292	812	70,5	151	181	350	LS 200 LT	FCPL 54H1D <sup>2</sup>	390	283	134	823	96,5	92	63	242		
LSES 280 SD	479	405	292	872	70,5	151	181	428	LS 225 ST	FCPL 54H1D <sup>2</sup>	390	283	134	823	96,5	92	63	242		
LSES 280 MD	479	405	292	872	70,5	151	181	470	LS 225 MR	FCPL 54H1D <sup>2</sup>	390	283	134	865	96,5	92	63	274		

<sup>1</sup> except brake motor in italics

<sup>2</sup> with CDF board

Dimensions  
Cb combined

Dimensions in millimetres

Tapped form BT

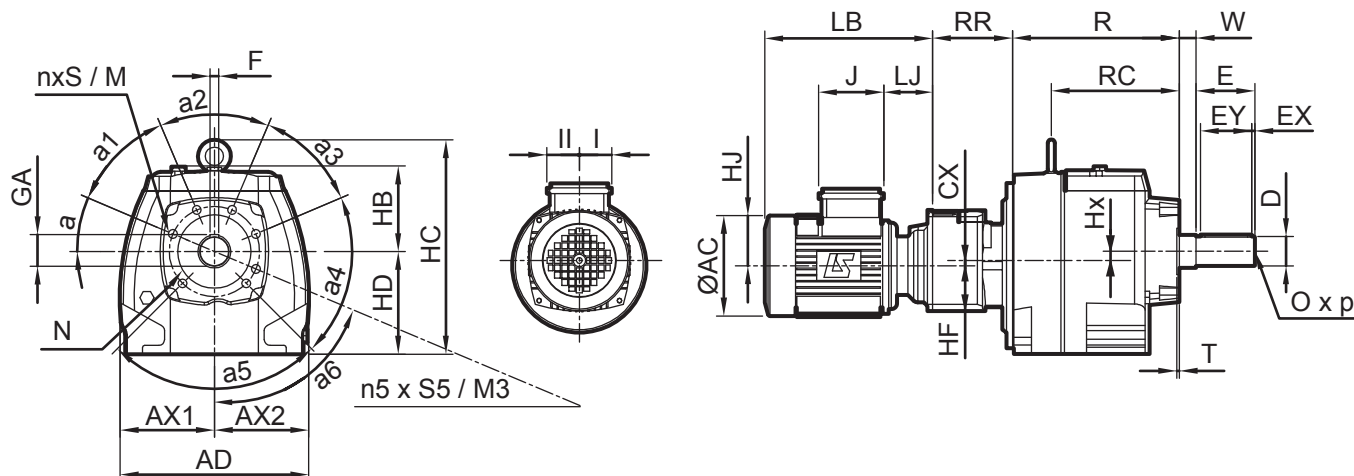

Cb	Compabloc											BT								kg				
	AD	AX1	AX2	CX	HB	HC	HD	HD	HF	HX	R	RC	RR	W	a° to axx°	ØN	n	ØS	ØM		ØN	n5	ØS5	ØM3
Cb 3835	608	304	304	26	244	662	290	355	154	65	505	365	229	80	on page 144	250H7	11	M20x35	300	250H7	2	16x20	300	346
Cb 3735	518	259	259	10	203	572	255	315	105	60	420	322	177.5	80	on page 142	180K6	9	M20x35	230	180K6	1	16x20	230	211
Cb 3635	449	224.5	224.5	10	200	485	222	250	105	28	352	262	177.5	80	on page 140	150K6	6+1	M16x27	230/220	150K6	1	16x20	192	181
Cb 3535	360	180	180	8.5	143	434.5	196	225	81.5	29	281	214.5	168.5	34	on page 138	155j6	6	M16x27	190	155j6	1	10.2x27	190	99.4
Cb 3435	305	152.5	152.5	8.5	115	360.5	154	180	81.5	26	242	184	176.5	28	on page 136	130j6	6	M12x22	152	130j6	1	10.2x27	152	61.4
Cb 3335	257	128.5	128.5	-7	108.5	292.5	120.5	140	70	19.5	227.5	174.5	109	23	on page 134	100K6	6	M12x22	123	100j6	1	10.2x27	123	33.9
Cb 3235	222	115	107	-7	89	232.5	105	115	70	10	177.5	130.5	113	15	on page 132	82j6	6	M10x22	100	82j6	1	8x20	102	23.1

Cb	Shaft extension							
	ØD	E	EX	EY	F	GA	O	Z
Cb 3835	110m6	210	12	180	28	116	M24	50
Cb 3735	90m6	170	12	140	25	95	M24	50
Cb 3635	70m6	140	10	115	20	74.5	M20	42
Cb 3535	60m6	120	4.5	110	18	64	M20	42
Cb 3435	50k6	100	3.5	90	14	53.5	M16	36
Cb 3335	40k6	80	4	70	12	43	M16	36
Cb 3235	30j6	60	3.5	50	8	33	M10	22

Cb	IMfinity® three-phase 4-pole						kg	IMfinity® three-phase 4-pole and brake						kg			
	AC	HJ	J	LB	LJ	I		II	AC	HJ	J	LB	LJ		I	II	
Cb 3835																	
Cb 3735																	
Cb 3635																	
Cb 3535																	
Cb 3435																	
Cb 3335																	
Cb 3235																	

Dimensions  
Cb combined

Dimensions in millimetres

Feet S

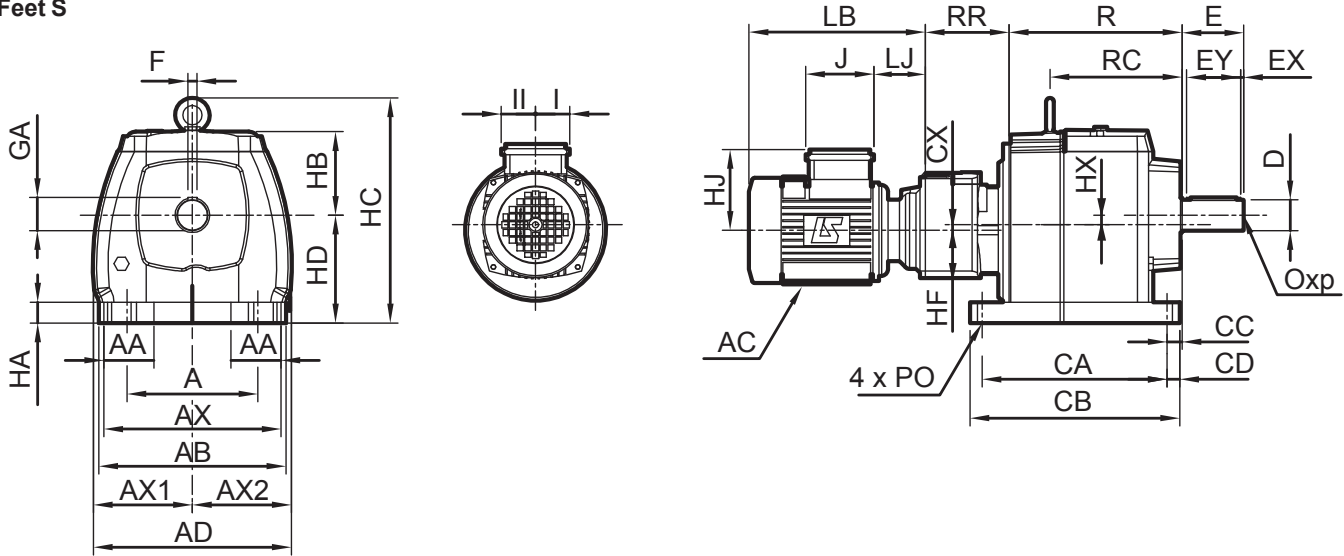

Cb	Compabloc													kg									
	A	AA	AB	AD	AX	AX1	AX2	CA	CB	CC	CD	CX	HA		HB	HC	HD	HF	HX	ØPO	R	RC	RR
Cb 3835	510	84	598	608	587	304	304	480	550	50	35	26	62	244	662	355	154	65	26	505	365	229	345
Cb 3735	420	60	498	518	479	259	259	390	455	65	36	10	55	203	572	315	105	60	26	422	324	177.5	210.7
Cb 3635	419	70	440	449	419	224.5	224.5	355	405	60	25	10	45	200	485	250	105	28	26	354	264	177.5	180.7
Cb 3535	280	90	342	360	326	180	180	280	327.5	28	24	8.5	43	143	434.5	225	81.5	29	22	290	223.5	168.5	103.4
Cb 3435	230	80	288	305	270	152.5	152.5	235	275	25	19	8.5	35	115	360.5	180	81.5	26	18	251	193	176.5	54.8
Cb 3335	170	65	243	257	230	128.5	128.5	240	272.5	19.5	16	-7	27	108.5	292.5	140	70	19.5	18	224.5	171.5	109	34.8
Cb 3235	135	65	208	222	198	115	107	192	216	13	11.5	-7	21	89	232.5	115	70	10	14	182.5	135.5	113	23.3

Flange BS

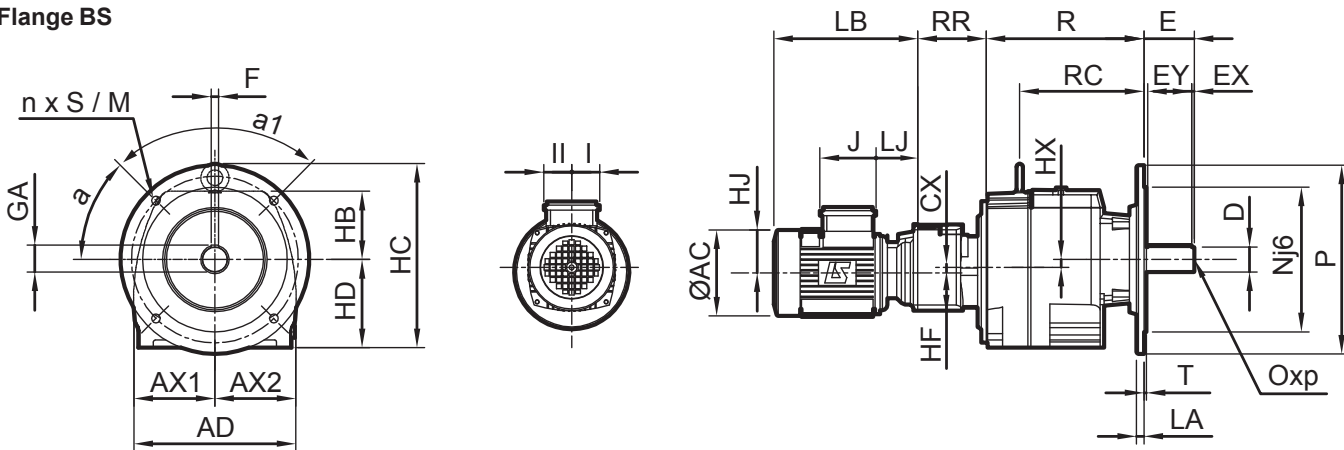

Cb	Compabloc													BS							kg	
	AD	AX1	AX2	CX	HB	HC	HD	HF	HX	R	RC	RR	LA	ØM	ØN	ØP	S	T	a°	a1		n
Cb 3835	608	304	304	26	244	662	355	154	65	585	445	229	24	600	550j6	660	24	6	22.5	45	8	380
Cb 3735	518	259	259	10	203	572	315	105	60	500	402	177.5	20	500	450j6	550	18.5	6	22.5	45	8	213
Cb 3635	449	224.5	224.5	10	200	485	250	105	28	432	342	177.5	20	500	450j6	550	18.5	6	22.5	45	8	165
Cb 3535	360	180	180	8.5	143	434.5	225	81.5	29	315	248.5	168.5	18	350	300	400	18	5	22.5	45	8	110
Cb 3435	305	152.5	152.5	8.5	115	360.5	180	81.5	26	270	212	176.5	15	300	250	350	14	4	45	90	4	60.8
Cb 3335	257	128.5	128.5	-7	108.5	292.5	140	70	19.5	250.5	197.5	109	12	265	230	300	14	4	45	90	4	38.4
Cb 3235	222	115	107	-7	89	232.5	115	70	10	192.5	145.5	113	12	215	180	250	14	4	45	90	4	23.9

Dimensions

Cb - Universal mounting U

Dimensions in millimetres

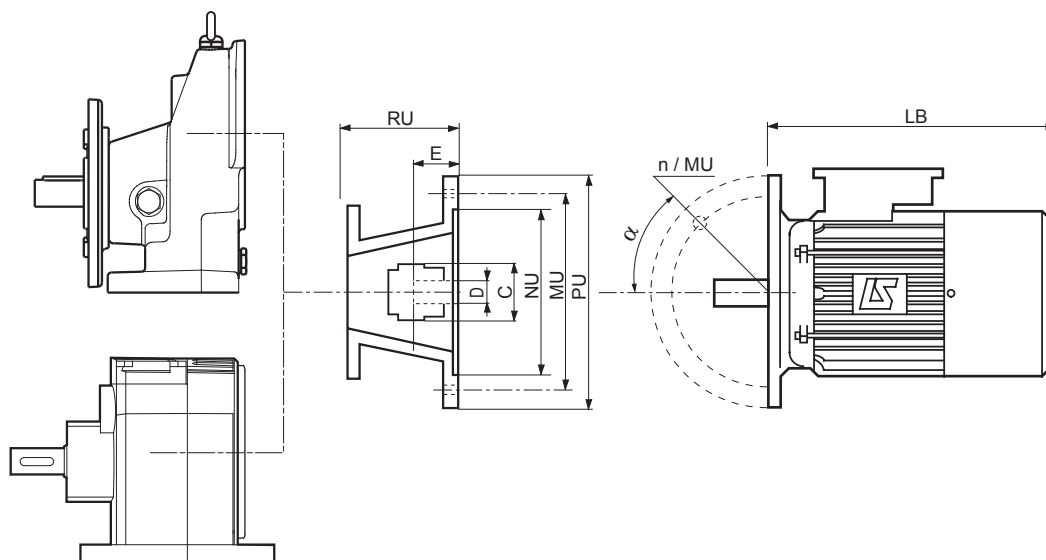

Type	LS, LSES IM 3001									U-mount																		
	(IM B5) CEI									Cb 15--		Cb 30--		Cb 31--		Cb 32--		Cb 33--		Cb 34--		Cb 35--		Cb 36/37--		Cb 38--		
	Ø D	E	LB <sup>1</sup> /LB <sup>2</sup> Max	LB FMD/FFB/FCPL	Ø MU	Ø NU	Ø PU	n	α°	Ø C	RU	Ø C	RU <sup>3</sup>	Ø C	RU <sup>3</sup>	Ø C	RU	Ø C	RU	Ø C	RU	Ø C	RU	Ø C	RU	Ø C	RU	
LS56M	9j6	20	156/134	206	FF100	80	120	4	45	-	50	-	-	-	-	-	-	-	-	-	-	-	-	-	-	-	-	
LS, LSES 63M	11j6	23	172/165	222	FF115	95	140	4	45	-	50	-	60	-	-	-	-	-	-	-	-	-	-	-	-	-	-	
LS, LSES 71LR	14j6	30	233	233/296	FF130	110	160	4	45	-	50	-	60	65	122	65	122	65	122	65	122	-	-	-	-	-	-	-
LS, LSES 80	19j6	40	267	409	FF165	130	200	4	45	-	-	-	90	65	130	65	130	65	130	65	130	65	121	-	-	-	-	-
LS, LSES 90	24j6	50	285	409	FF165	130	200	4	45	-	-	-	-	65	130	65	130	65	130	65	130	65	121	-	-	-	-	-
LS, LSES 100	28j6	60	315	437	FF215	180	250	4	45	-	-	-	-	65	144	65	144	65	144	65	144	65	135	65	148	65	136	
LS, LSES 112	28j6	60	332	448	FF215	180	250	4	45	-	-	-	-	65	144	65	144	65	144	65	144	65	135	65	148	65	136	
LS, LSES 132	38k6	80	412	621	FF265	230	300	4	45	-	-	-	-	-	-	-	65	162	65	169	65	157.5	65	167	65	156		
LS, LSES 160	42k6	110	510	682	FF300	250	350	4	45	-	-	-	-	-	-	-	-	-	95	194	95	183	95	199	95	187		
LS, LSES 180	48k6	110	552	683	FF300	250	350	4	45	-	-	-	-	-	-	-	-	-	95	194	95	183	95	199	95	187		
LS, LSES 200	55m6	110	669	785	FF350	300	400	4	45	-	-	-	-	-	-	-	-	-	95	194	95	183	95	199	95	187		
LS, LSES 225	60m6	140	810	880	FF400	350	450	8	22,5	-	-	-	-	-	-	-	-	-	-	-	-	-	-	120	245	120	233	
LS, LSES 250 <sup>1</sup>	65m6	140	810	1116	FF500	450	550	8	22,5	-	-	-	-	-	-	-	-	-	-	-	-	-	-	120	328	160	316	
LS, LSES 280 <sup>1</sup>	75m6	140	870	1116	FF500	450	550	8	22,5	-	-	-	-	-	-	-	-	-	-	-	-	-	-	120	328	160	316	
LS, LSES 315 <sup>1</sup>	80m6	170	947	1116	FF600	550	660	8	22,5	-	-	-	-	-	-	-	-	-	-	-	-	-	-	-	-	200	366	

LB<sup>1</sup>: ventilated motor - LB<sup>2</sup>: not ventilated motor











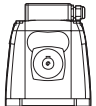





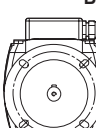

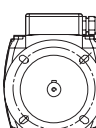
<sup>1</sup> feet and flange motors (B35) in horizontal mounting. A motor support is recommended.

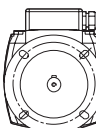
	Cb									
	15--	30--	31--	32--	33--	34--	35--	36--	37--	38--
MU max (kg)	0.6	3	4	8	14	20	35	75	75	117
LS max (kg) <sup>1</sup>	10	30	65	70	120	150	205	350	350	350

<sup>1</sup> maximum motor weight permissible in B5

### Dimensions Synthesis

Dimensions in millimetres

Mountings		COMPABLOC										
		Cb 15xx	Cb 30xx	Cb 31xx	Cb 32xx	Cb 33xx	Cb 34xx	Cb 35xx	Cb 3633	Cb 3733	Cb 3833	
	Shaft	1 	-	16j6 x 40	20j6 x 40	25j6 x 50	35k6 x 70	40k6 x 80	45k6 x 90	-	-	-
		2-3 	16j6 x 40	20j6 x 40	25j6 x 50	30j6 x 60	40k6 x 80	50k6 x 100	60m6 x 120	70m6 x 140	90m6 x 170	110m6 x 210
	Shaft	1 	-	16j6 x 40 + 12 M = 100 N = 60	20j6 x 40 + 15 M = 83 N = 70	25j6 x 50 + 15 M = 83 N = 70	35k6 x 70 + 15 M = 120 N = 100	40k6 x 80 + 28 M = 152 N = 130	45k6 x 90 + 34 M = 190 N = 140	-	-	-
	Shaft Ø	2-3 	-	20j6 x 40 + 12 op. 25j6 x 50 M = 100 N = 60	25j6 x 50 + 15 M = 83 N = 70	30j6 x 60 + 15 M = 100 N = 82	40k6 x 80 + 23 M = 123 N = 100	50k6 x 100 + 28 M = 152 N = 130	60m6 x 120 + 34 M = 190 N = 155	70m6 x 140 + 80 M = 230 N = 150	90m6 x 170 + 80 M = 230 N = 180	110m6 x 210 + 80 M = 300 N = 250
	Shaft	1 	-	16j6 x 40 M = 115 N = 95 P = 140	20j6 x 40 M = 130 N = 110 P = 160	25j6 x 50 M = 165 N = 130 P = 200	35k6 x 70 M = 215 N = 180 P = 250	40k6 x 80 M = 265 N = 230 P = 300	45k6 x 90 M = 300 N = 250 P = 350	-	-	-
	Flange Ø	2-3 	16j6 x 40 M = 100 N = 80 P = 120	20j6 x 40 op. 25j6 x 50 M = 115 N = 95 P = 140	25j6 x 50 M = 165 N = 130 P = 200	30j6 x 60 M = 215 N = 180 P = 250	40k6 x 80 M = 265 N = 230 P = 300	50k6 x 100 M = 300 N = 250 P = 350	60m6 x 120 M = 350 N = 300 P = 400	70m6 x 140 M = 500 N = 450 P = 550	90m6 x 170 M = 500 N = 450 P = 550	110m6 x 210 M = 600 N = 550 P = 660
	Shaft	1 	-	16j6 x 40 M = 100 N = 80 P = 120	20j6 x 40 M = 115 N = 95 P = 140	25j6 x 50 M = 130 N = 110 P = 160	35k6 x 70 M = 165 N = 130 P = 200	40k6 x 80 M = 215 N = 180 P = 250	45k6 x 90 M = 265 N = 230 P = 300	-	-	-
	Flange Ø	2-3 	16j6 x 40 M = 85 N = 70 P = 105	20j6 x 40 op. 25j6 x 50 M = 100 N = 80 P = 120	25j6 x 50 M = 130 N = 110 P = 160	30j6 x 60 M = 165 N = 130 P = 200	40k6 x 80 M = 215 N = 180 P = 250	50k6 x 100 M = 265 N = 230 P = 300	60m6 x 120 M = 300 N = 250 P = 350	70m6 x 140 M = 400 N = 350 P = 450	90m6 x 170 M = 400 N = 350 P = 450	100m6 x 210 M = 500 N = 450 P = 550
	Shaft	1 	-	16j6 x 40 M = 130 N = 110 P = 160	-	-	-	-	-	-	-	-
	Flange Ø	2-3 	16j6 x 40 M = 115 N = 95 P = 140	20j6 x 40 op. 25j6 x 50 M = 130 N = 110 P = 160	25j6 x 50 M = 115 N = 95 P = 140	30j6 x 60 M = 130 N = 110 P = 160	40k6 x 80 M = 165 N = 130 P = 200	50k6 x 100 M = 215 N = 180 P = 250	60m6 x 120 M = 265 N = 230 P = 300	-	-	-
	Shaft	1 	-	16j6 x 40 M = 165 N = 130 P = 200	-	-	-	-	-	-	-	-
	Flange Ø	2-3 	-	20j6 x 40 op. 25j6 x 50 M = 165 N = 130 P = 200	25j6 x 50 M = 100 N = 80 P = 120	-	-	-	-	-	-	-
	Shaft	2-3 	-	-	-	-	45k6 x 90 M = 215 N = 180 P = 250	55k6 x 110 M = 265 N = 230 P = 300	65m6 x 130 M = 300 N = 250 P = 350	-	-	-
	Flange Ø		-	-	-	-	-	-	-	-	-	-
	56	FF100-9X20	FF100-9X20	-	-	-	-	-	-	-	-	-
	63	FF115-11X23	FF115-11X23	-	-	-	-	-	-	-	-	-
	71	FF130-14X30	FF130-14X30	FF130-14X30	FF130-14X30	FF130-14X30	FF130-14X30	-	-	-	-	-
	80	-	FF165-19X40	FF165-19X40	FF165-19X40	FF165-19X40	FF165-19X40	FF165-19X40	FF165-19X40	-	-	-
	90	-	-	FF165-24X50	FF165-24X50	FF165-24X50	FF165-24X50	FF165-24X50	FF165-24X50	-	-	-
	100	-	-	FF215-28X60	FF215-28X60	FF215-28X60	FF215-28X60	FF215-28X60	FF215-28X60	FF215-28X60	FF215-28X60	-
	112	-	-	FF215-28X60	FF215-28X60	FF215-28X60	FF215-28X60	FF215-28X60	FF215-28X60	FF215-28X60	FF215-28X60	FF215-28X60
	132	-	-	-	-	-	FF265-38X80	FF265-38X80	FF265-38X80	FF265-38X80	FF265-38X80	FF265-38X80
	160	-	-	-	-	-	FF300-42X110	FF300-42X110	FF300-42X110	FF300-42X110	FF300-42X110	FF300-42X110
	180	-	-	-	-	-	FF300-48X110	FF300-48X110	FF300-48X110	FF300-48X110	FF300-48X110	FF300-48X110
	200	-	-	-	-	-	FF350-55X110	FF350-55X110	FF350-55X110	FF350-55X110	FF350-55X110	FF350-55X110
	225	-	-	-	-	-	-	-	FF400-60X140	FF400-60X140	FF400-60X140	FF400-60X140
	250	-	-	-	-	-	-	-	FF500-65X140	FF500-65X140	FF500-65X140	FF500-65X140
	280	-	-	-	-	-	-	-	FF500-75X140	FF500-75X140	FF500-75X140	FF500-75X140
315	-	-	-	-	-	-	-	-	-	-	FF600-80X170	

## Equipment and options

### BACKSTOP

The gearboxes Cb 36 up to 38 are feasible in version **input shaft with backstop as an option**: a device that allows only one direction of rotation on output shaft.

#### Designation:

Cb3633 i 50.4 S S B3 AP

With back stop Clockwise;  
Exchanger 10 kW supplied, not mounted.

The geared motors Cb 30 up to 38\* / LSES IFT/IE3 are feasible with AD backstop option: a device that allows only one direction of rotation on output shaft, with input speed to the gearbox not exceeding 3000 min<sup>-1</sup>.

*\*For Cb 30 to 35: minimum motor speed 600 min<sup>-1</sup> in continuous duty.*

*Speed < 600 min<sup>-1</sup> allowed on starting phase and intermittent duty only.*

#### Designation:

Cb3633 i 50.4 S S B3 / MI 4 poles

LSES 160 M 11 kW IFT/IE3, with back stop CLOCKWISE.

**When ordering, please indicate the direction of rotation of output shaft: clockwise or counterclockwise.**

(as seen from output shaft, side F, motor behind).

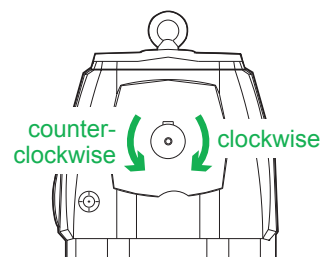

Label indicating the output shaft direction of rotation.



321344a  
Counter-clockwise

321343a  
Clockwise

Dimensions in millimetres

### HEAT EXCHANGER

An external cooling system is required to maintain the performance of the geared motor. We recommend the heat exchanger on the right, approved by our technical services. It comprises: a metallic housing (1), a motor (2), a pump (3), a fan (4) with the following characteristics:

- Motor: 1.1 kW, 4 poles, IP 55
- Maximum dissipation: 10 kW
- Flow rate: 40l/min for 40 cSt - 4 bar
- Max oil temperature: 90°C

The cooling air flow must be free of obstacles. For the ideal air intake and discharge distance, refer to dimensions W1 and W2 (mm) in the following table.

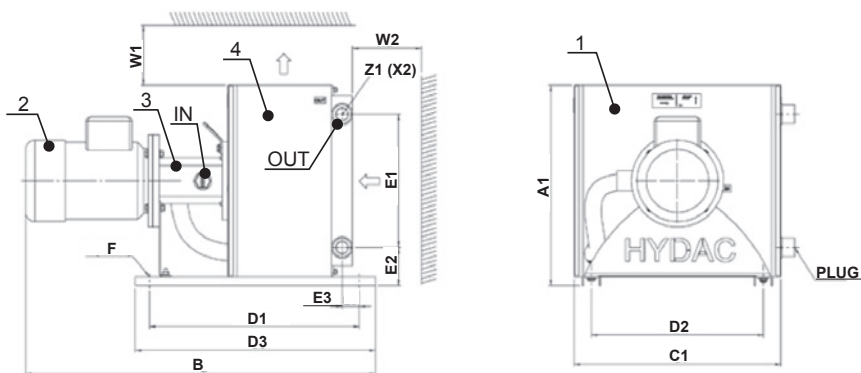

Dimensions (mm)

A1	B	C1	D1	D2	D3	E1	E2	E3	F	W1 min	W2 min	Z1 IN	Z2 OUT	Ⓢ kg
433	766	449	455	373	521	288	83	37.5	9	1.000	300	G1"	G3/4"	40

## Equipment and options

### FEET AND FLANGE FORM

Dimensions in millimetres

#### 1 stage Compabloc

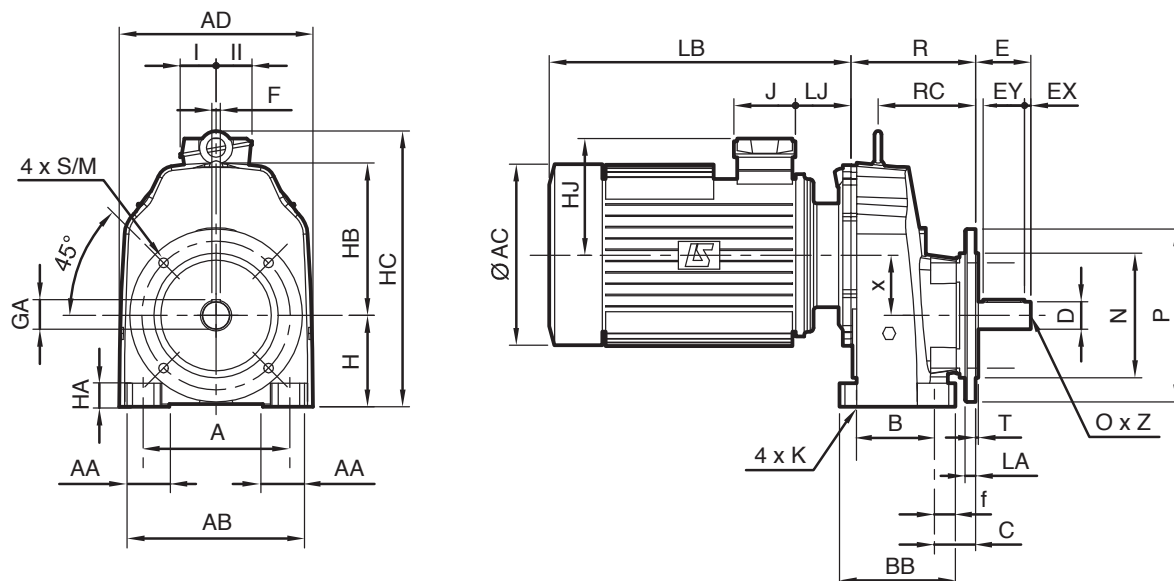

Cb	Compabloc															kg	
	A	AA	AB	AD	B	BB	C	f	H	HA	HB	HC	ø K	R	RC		x
<b>Cb 3531</b>	260	85	344	344	160	197	55.5	18	160	42	280	484	18	200.5	152.5	110	48
<b>Cb 3431</b>	216	67	257	280	125	168	47.5	18	132	34	221	399	18	180	141	87	31
<b>Cb 3331</b>	190	59	240	240	100	135	37.5	18.5	112	26	185	343	16	146	116	70	19.4
<b>Cb 3231</b>	140	52.5	180	185	80	110	27	14	90	21	155.5	292	14	124	102	63	10.3
<b>Cb 3131</b>	120	38	156	152	75	105	26	18	80	17	123	248	11	121	94	46.5	8.1

Cb	SBS					
	LA	ø M	ø N	ø P	ø S	T
<b>Cb 3531</b>	18	300	250	350	18	5
<b>Cb 3431</b>	15	265	230	300	14	4
<b>Cb 3331</b>	12	215	180	250	14	4
<b>Cb 3231</b>	10	165	130	200	12	3.5
<b>Cb 3131</b>	10	130	110	160	9	3.5

Cb	SBD1					
	LA	ø M	ø N	ø P	ø S	T
<b>Cb 3531</b>	18	265	230	300	14	5
<b>Cb 3431</b>	13	215	180	250	14	4
<b>Cb 3331</b>	12	165	130	200	11	4
<b>Cb 3231</b>	10	130	110	160	9	3.5
<b>Cb 3131</b>	10	115	95	140	9	3.5

Cb	BA							
	ø D	E	EX	EY	F	GA	O	Z
<b>Cb 3531</b>	45k6	90	12	66	14	48.5	M16	36
<b>Cb 3431</b>	40k6	80	9	60	12	43	M16	36
<b>Cb 3331</b>	35k6	70	2	63	10	38	M12	38
<b>Cb 3231</b>	25j6	50	5	40	8	28	M10	22
<b>Cb 3131</b>	20j6	40	6.5	30	6	22.5	M6	16

Cb	LS							kg
	AC	HJ	J	LB	LJ	I	II	
<b>Cb 3531</b>	on page 123							
<b>Cb 3431</b>	on page 121							
<b>Cb 3331</b>	on page 119							
<b>Cb 3231</b>	on page 117							
<b>Cb 3131</b>	on page 115							

## Equipment and options

### FEET AND FLANGE FORM

Dimensions in millimetres

#### Compabloc 2, 3 stages

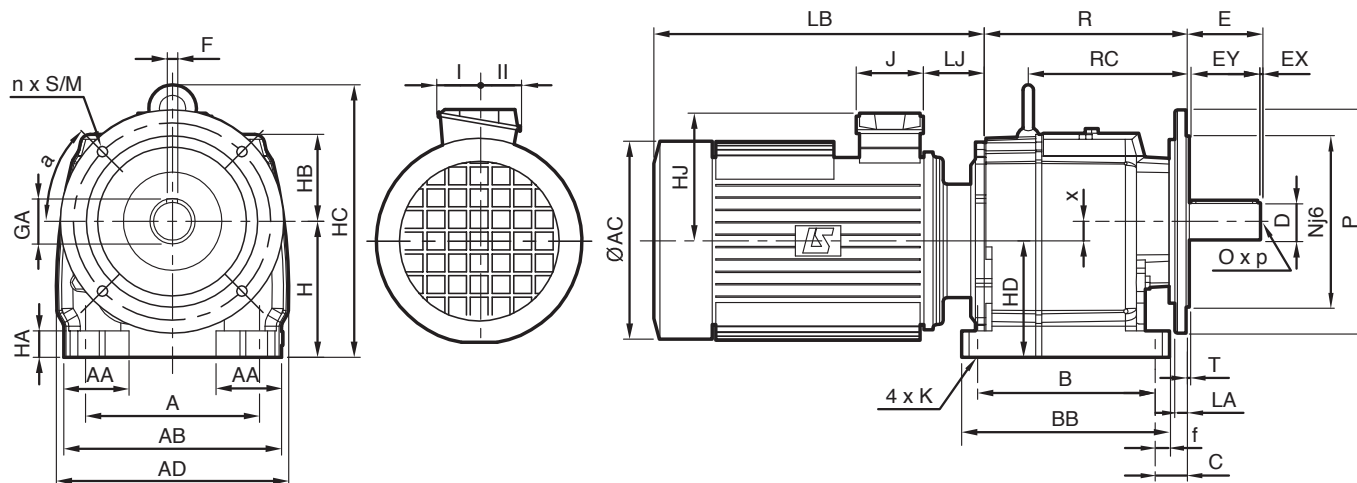

Cb	Compabloc													Compabloc SBS						kg					
	A	AA	AB	AD	B	BB	C	f	H	HA	HB	HC	øK	R	x	LA	ØM	ØN	ØP		R	RC	nxØS	T	a°
<b>Cb 3533</b>	280	90	342	360	280	327.5	49	25	225	43	143	434.5	196	22	29	18	350	300	400	315	248.5	4x18	5	45	103
<b>Cb 3433</b>	230	80	288	305	235	375	44	19	180	35	115	360.5	154	18	26	15	300	250	350	270	212	4x14	4	45	58
<b>Cb 3333</b>	170	65	243	257	240	272.5	45.5	16	140	27	108.5	292.5	120.5	18	19.5	12	265	230	300	250.5	197.5	4x14	4	45	35
<b>Cb 3233</b>	135	65	208	222	192	216	23	11.5	115	21	89	232.5	105	14	10	12	215	180	250	192.5	145.5	4x12	4	45	20
<b>Cb 3133</b>	110	35	160	172	165	195	24	15	90	20	73.5	203	81.5	9	8.5	-	-	-	-	-	-	-	-	-	-

Cb	Compabloc SBD1									kg
	LA	ØM	ØN	ØP	R	RC	nxØS	T	a°	
<b>Cb 3533</b>	18	300	250	350	315	248.5	4x18	5	45	103
<b>Cb 3433</b>	15	265	230	300	270	212	4x14	4	45	59
<b>Cb 3333</b>	12	215	180	250	250.5	197.5	4x14	4	45	36
<b>Cb 3233</b>	10	165	130	200	192.5	145.5	4x12	3.5	45	19
<b>Cb 3133</b>	10	130	110	160	173.5	175.5	4x9	3.5	45	14
<b>Cb 30xx</b>	-	-	-	-	-	-	-	-	-	-

Cb	Compabloc SBD2									kg
	LA	ØM	ØN	ØP	R	RC	nxØS	T	a°	
<b>Cb 3533</b>	18	265	230	300	315	248.5	4x14	5	45	100
<b>Cb 3433</b>	15	215	180	250	270	212	4x14	4	45	58
<b>Cb 3333</b>	12	165	130	200	250.5	197.5	4x11	3.5	45	34.5
<b>Cb 3233</b>	10	130	110	160	192.5	145.5	4x12	3.5	45	18.8
<b>Cb 3133</b>	10	115	95	140	173.5	180.5	4x9	3.5	45	13.5
<b>Cb 30xx</b>	-	-	-	-	-	-	-	-	-	-

Cb	Compabloc SBD3									kg
	LA	ØM	ØN	ØP	R	RC	nxØS	T	a°	
<b>Cb 3133</b>	10	100	80	120	173.5	180.5	4x12	3.5	45	13.3

Cb	IMfinity® three-phase 4-pole							kg
	AC	HJ	J	LB	LJ	I	II	
<b>Cb 3533</b>								on page 139
<b>Cb 3433</b>								on page 137
<b>Cb 3333</b>								on page 135
<b>Cb 3233</b>								on page 133
<b>Cb 3133</b>								on page 131

Cb	IMfinity® three-phase 4-pole and brake							kg
	AC	HJ	J	LB	LJ	I	II	
								on page 139
								on page 137
								on page 135
								on page 133
								on page 131



## Identification

### GEARBOX NAMEPLATES

Nameplates identify the equipment, indicate the main performance and show its compatibility with the main standards and regulations related to them.

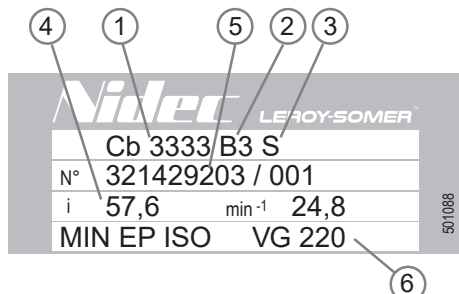

#### Information to be reminded whenever ordering spare parts:

① Cb: Compabloc gearbox 3333: gearbox type	② B3: operating position	③ S: fixing form	④ i: exact reduction	⑤ No.: batch no; N/ 001: serial number	⑥ MIN EP ISO VG: lubrication according to ISO 220: viscosity grade at 40°C in cSt Option: lubrication with synthetic oil PAO ISO VG 150	min⁻¹: number of revolutions per minute
--	-----------------------------	---------------------	-------------------------	--	--	---

#### ATEX specific marking

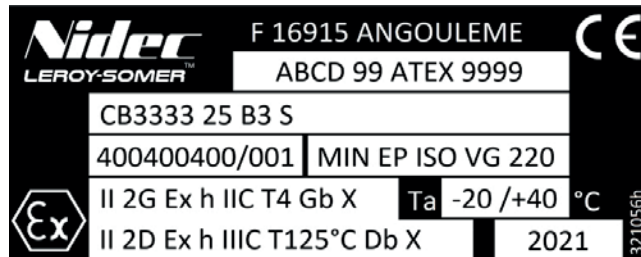

 Legal marking indicating that the equipment conforms to the requirements of the European Directives.

#### ATEX specific marking

	Spécific markings
N°	Specific filing number (II2G/II2D).
II 2D / II 3D	Group II, category 2 or 3, dust
II 2G / II 3G	Group II, category 2 or 3, Gas
h	Mesh point protection
IIB / IIC	Explosion group (gas)
IIIB / IIIC	Explosion group (dust)
T4 / T5	Temperature class
T125°C	Maximum surface temperature
Gb/Gc/Db/Dc	EPL ( Equipment Protection Level)

If there is an «X» at the end of the ATEX marking or the filing number, take into account the special conditions of use.

## Identification

### LSES ALUMINIUM MOTORS NAMEPLATES

IE3 power  $\geq 7.5$  kW\*

Mains supply plate

Ta 40°C Ins.Cl. F S1		1000m 225kg		IE3	
DE: 6312 ZZ C3				NEMA Norm Eff. 94, 1%	
NDE: 6312 ZZ C3					
V	Hz	min-1	kW	cosφ	A
Δ 380	50	1472	30.0	0.85	57.3
Δ 400	50	1476	30.0	0.84	55.0
Δ 415	50	1478	30.0	0.84	54.1
Δ 460	60	1776	30.0	0.83	46.0

Drive supply plate

Ta 40°C Ins.Cl. F S9		1000m 225kg		IE3	
DE: 6312 ZZ C3				NEMA Norm Eff. 94, 1%	
NDE: 6312 ZZ C3					
V	Hz	min-1	kW	cosφ	A
Δ 400	50	1472	30.0	0.85	59.1
					min.Fsw(kHz) 3
					Nmax(In-r) 2610
Motor performance					
Hz	10	17	25	50	87
T/Tn%	80	90	100	100	57
					Tn(Nm): 194

IE3 power  $< 7.5$  kW\*

Mains supply plate

Ta 40°C Ins.Cl. F S1		1000m 37kg		IE3	
DE: 6206 ZZ C3				NEMA Norm Eff. 88,6%	
NDE: 6206 ZZ C3					
V	Hz	min-1	kW	cosφ	A
Y 380	50	1452	4.00	0.85	8.05
Δ 230	50	1456	4.00	0.82	13.7
Y 400	50	1456	4.00	0.82	7.90
Y 415	50	1460	4.00	0.80	7.80
Y 460	60	1764	4.00	0.79	7.05

Drive supply plate

Ta 40°C Ins.Cl. F S9		1000m 37kg		IE3	
DE: 6206 ZZ C3				NEMA Norm Eff. 89,5%	
NDE: 6206 ZZ C3					
V	Hz	min-1	kW	cosφ	A
Y 400	50	1452	4.00	0.85	8.45
Δ 400	87	2562	6.96	0.85	14.7
Motor performance					
Hz	10	17	25	50	87
T/Tn%	90	100	100	100	57
					min.Fsw(kHz) 3
					Tn(Nm): 26.2

\* Valid only for 2 & 4 pole motors, except for 2P 3 kW and 4P 2.2 kW.

6P aluminium motors of all power levels and 2P 3 kW and 4P 2.2 kW can be offered in CSAe, ee, cCSAus, NEMA Premium versions optionally upon specific request.

Plate values provided for information only.

## Identification

### NAMEPLATES

Nameplates identify the equipment, indicate the main performance and show its compatibility with the main standards and regulations related to them.

### DEFINITION OF NAMEPLATE SYMBOLS



Legal sign that the equipment conforms to the requirements of European Directives.

#### Mains supply plate:

**MOT 3 ~** : three-phase A.C. motor  
**LSES** : series  
**200** : frame size  
**LU** : housing symbol  
**T** : impregnation index

#### Motor no.

**123456** : motor batch number  
**A** : month of production  
**19** : year of production  
**001** : serial number  
**IE3** : efficiency class  
**93.6%** : efficiency at 4/4 load

**IP55 IK08** : protection index  
**I cl. F** : insulation class F  
**40°C** : contractual ambient temperature for operation  
**S1** : duty - operating factor  
**kg** : weight  
**V** : supply voltage  
**Hz** : supply frequency  
**min<sup>-1</sup>** : number of revolutions per minute  
**kW** : rated power  
**cos φ** : power factor  
**A** : rated current  
**Δ** : delta connection  
**Y** : star connection

#### Bearings

**DE** : drive end bearing  
**NDE** : non-drive end bearing  
**g** : amount of grease at each regreasing (g)  
**h** : greasing interval (hours)

**POLYREX EM103**: type of grease



: vibration level



: balancing mode

**Information to be reminded whenever ordering spare parts**

#### Drive supply plate:

**Inverter settings**: values necessary to set the frequency inverter

**Motor performance**: torque available on the motor shaft in % rated torque at the plate frequencies

**Min. Fsw (kHz)**: minimum cut-off frequency acceptable for the motor

**Nmax (min<sup>-1</sup>)**: maximum mechanical speed acceptable for the motor

## Identification

### FFB BRAKE MOTORS NAMEPLATES

Check that the equipment conforms to the order: mounting arrangement, information on the nameplate.

Information ① to ⑪ should be quoted when ordering spare parts.

Other logos can optionally be provided: agreement prior to ordering is essential.

Example: LSES 100 LG FFB3 IT/IE3

#### MOTOR NAMEPLATE FOR FFB BRAKE

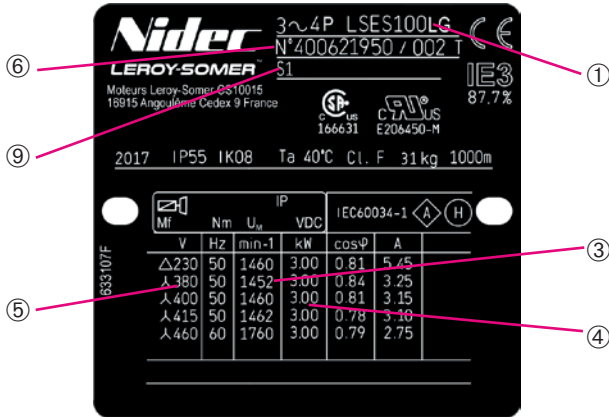

#### Definition of the symbols

T : Impregnation class

IE2: Efficiency class

IP-- IK--: protection ratings\*

CI.F : Insulation class

(Ta) 40°C: contractual ambient temperature for operation

cos P or φ: power factor

A : Rated current

Δ : delta connection

Λ : star connection

⊠ : vibration level

Ⓜ : balancing mode

#### BRAKE MOTOR NAMEPLATE WITH DRIVE

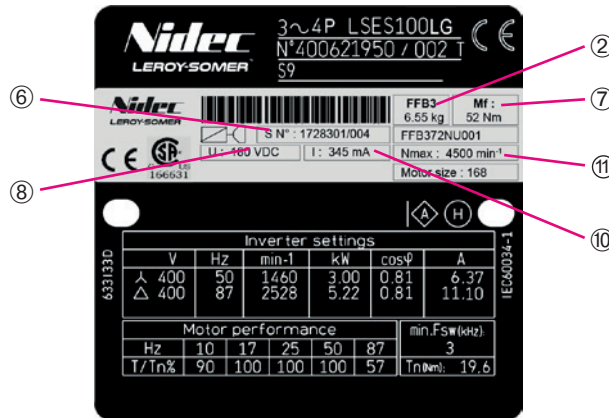

#### Bearings

DE: Drive End or Drive End bearing (side F)

NDE: Non Drive End or Non Drive End bearing (side B)

#### Marking

Definition of symbols used on nameplates

	Motor nameplate	FFB brake nameplate
CE	Legal mark of compliance of equipments with the requirements of European Directives	Frame size 71 to 180
CIA/US	Legal mark of compliance of equipments with the USA and Canada markets	Frame size 71* to 180
SR 166631	Legal mark of brake's compliance with the USA and Canada requirements	Frame size 80 to 180
71*	Legal mark of compliance of equipments with the USA and Canada requirements	*or optional Frame size 71

Essential information included on the nameplates:

①	Motor series, frame size
②	Brake type FFB <input checked="" type="checkbox"/> <input type="checkbox"/>
③	3 Speed of rotation (min <sup>-1</sup> )
④	Rated power (kW)
⑤	Motor voltage (V)
⑥	Motor and brake manufacturing No.
⑦	Mf: Braking torque (N.m)
⑧	U: Brake coil voltage (VDC)
⑨	Duty - Operating factor
⑩	I: Coil current (mA)
⑪	rpm: Maximum speed use

Please quote when ordering spare parts

#### \*IK: Shock resistance

The motor can withstand a weak mechanical shock (IK 08 according to EN 50102).

**The user shall provide additional protection if there is a risk of significant mechanical shock.**

## Identification

### FCPL BRAKE MOTORS NAMEPLATES

Nameplates identify the equipment, indicate the main performance and show its compatibility with the main standards and regulations related to them.

### DEFINITION OF NAMEPLATES SYMBOLS

**CE** Legal sign that the equipment conforms to the requirements of European Directives.

**EAC** Eurasian conformity

**Mains supply plate:**  
induction motor, short-circuit rotor

**LS** ..... : series  
**180** ..... : frame size  
**LR** ..... : housing description

#### Motor no.

**2016** ..... : year of production  
**M3722D16** ..... : motor batch number  
**001** ..... : Serial number  
**IP55** ..... : motor protection indices  
**22 kW** ..... : rated output power  
**3~ 4P** ..... : three-phase A.C. motor  
**Hz** ..... : supply frequency  
**cos φ** ..... : power factor  
**cl.F** ..... : insulation class F  
**Ta** ..... : 40°, contractual ambient temperature  
**min<sup>-1</sup>** ..... : number of revolutions per minute  
**S1** ..... : duty  
**V** ..... : supply voltage  
**A** ..... : rated current

**Brake** 

**FCPL 54H** ..... : type of brake  
**IP55** ..... : brake protection index  
**180 Nm** ..... : braking torque  
**180 V** ..... : brake supply voltage  
**0,5 A** ..... : brake coil current

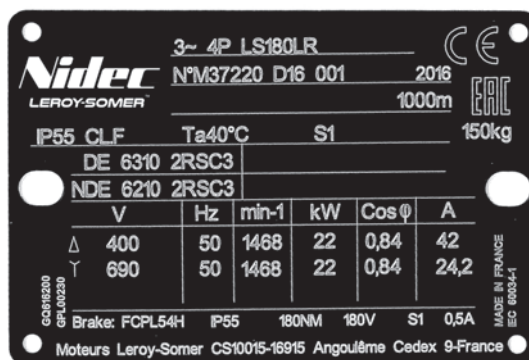

**Information to be reminded  
whenever ordering spare parts**

## Installation

### ACCEPTANCE TESTING

Check the condition of the equipment. In case of damage, either to the equipment or its packaging, record reservations with the carrier (if applicable, repairing may be excluded from the warranty).

Check that the equipment conforms to the order (construction shape, indications on nameplates)

See the leaflet reference 2557.

### HANDLING

- It is mandatory to use lifting devices, fitted on equipment.

### STORAGE

Store the equipment in a clean and dry location, protected from shocks, vibrations, temperature differences (between -30°C and +50°C) and in an atmosphere with a hygrometry below 80%.

Long-term storage (>1 year)

- Unless the equipment is lubricated for life, fill the gearbox completely with oil (upon commissioning, drain and top up as described in the manual of the gearbox concerned). Coat the external gasket(s) with grease.
- Enclose the unit in a sealed plastic bag (e.g. thermal glue) with a desiccant product inside.
- For manual release brake geared motors, release the brake to prevent sticking.

### COMMISSIONING

The installation must be performed by skilled personnel.

- Mount the gearboxes onto rigid and flat supports free of vibration. Use screws of appropriate length and class (class 8.8 min) and tighten them at 70 % their elastic limit.
- Remove the protections from the shaft(s) and flange(s): plastic end pieces, oil or varnish (use a solvent if required, while avoiding contact with the gaskets).
- For gearboxes lubricated with oil, check the oil level or top up.
- Fit the breather plug at the upper point of the gearbox when the equipment has one.
- Lubrication: see appropriate manuals. (p2)

Plan a sufficient distance around the geared motor for accessibility to the plugs (or vase):

200 mm: G1/4" plug std Cb 30 to 35

500 mm: G3/4" plug with gauge Cb 36 to 38

### LUBRICATION

For operation at an ambient temperature between -10°C and +40°C, the Compabloc series 3000 is supplied, as standard, lubricated with Extreme-Pressure mineral oil type EP ISO VG 220. Each gearbox is filled according to the operating position indicated in the order. Refer to the gearbox nameplate (p153) and installation manual reference 3520 for the quantity necessary to the operating position of your unit.

#### Lubrication kit

Certain operating positions or a high input speed require a lubrication kit to preserve the initial performance of gearboxes Cb 36 to 38 (manual reference 5088). In this case, implement a sufficient distance around the geared motor to ensure accessibility to the plugs (or expansion tank), with the machine stopped. (Installation manual reference 5088)

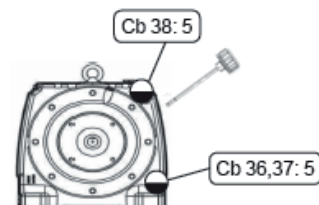
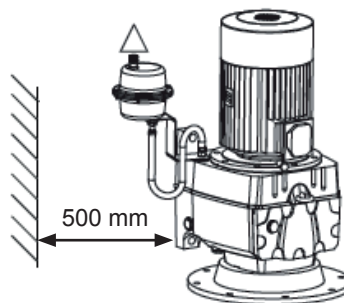
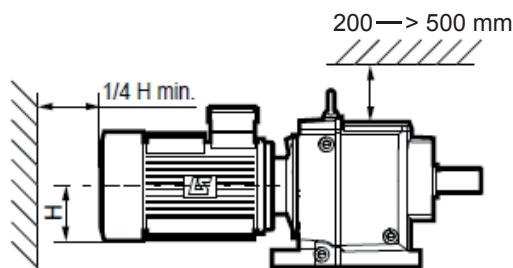

Entrée / Input / Motoren Flansch / Entrada

Example: Cb 36, 37, 38 in operating position V5 (foot mounted gearbox) or V1 (flange mounted gearbox).



In the case of a selection where the output shaft does not make a complete revolution, please consult to define the most appropriate quantity of oil and/or operating position.



Faulty maintenance may cause material or bodily damage. Check the mechanical and electrical installation instructions are applied over time.

## Installation

### PACKAGING WEIGHT AND DIMENSIONS

#### Transport by road (code 30) or air (code 40)

Cardboard box <sup>1</sup>		
Ref.	Tare	Dimensions (L x W x H) <sup>2</sup>
	kg	mm
P0 000	0.25	245 x 190 x 150
P0 100	0.35	256 x 222 x 165
P0 200	0.40	330 x 288 x 172
R1	0.25	330 x 145 x 200
R2	0.50	420 x 200 x 240
R3	0.65	520 x 220 x 280
R4	1.05	550 x 320 x 360
R5	0.85	580 x 260 x 280
R6	1.30	780 x 300 x 430
R7	0.75	420 x 300 x 260
R8	0.90	500 x 330 x 290
R5 Marine	0.85	580 x 260 x 280

Open-work pallet case or skylight case		
Tare	External dimensions (L x W x H) <sup>2</sup>	Internal dimensions (L x W x H) <sup>2</sup>
kg	mm	mm
10	720 x 420 x 550	650 x 350 x 400
26	830 x 520 x 660	760 x 450 x 500
30	990 x 570 x 620	920 x 500 x 550
47	920 x 870 x 700	850 x 800 x 550
48	990 x 870 x 880	920 x 800 x 720
45	1,270 x 870 x 700	1,200 x 800 x 550
47	1,270 x 870 x 880	1,200 x 800 x 720
61	1,270 x 1,070 x 730	1,200 x 1,000 x 550
62	1,270 x 1,070 x 900	1,200 x 1,000 x 720
64	1,270 x 1,070 x 1,050	1,200 x 1,000 x 870

#### Cases for maritime packaging (code 10)

Reinforced cases with plywood panels		
Tare	External dimensions (L x W x H) <sup>2</sup>	Internal dimensions (L x W x H) <sup>2</sup>
kg	mm	mm
20	740 x 480 x 730	680 x 420 x 600
26	840 x 520 x 710	760 x 440 x 530
30	980 x 560 x 720	920 x 500 x 550
58	1,120 x 750 x 850	1,040 x 680 x 670
60	1,100 x 950 x 680	1,020 x 870 x 500
80	1,100 x 950 x 1,180	1,020 x 870 x 1,000

<sup>1</sup> maximum permissible weight: 50 kg

<sup>2</sup> these approximate values are indicated for unit packaging. Grouped crate packaging is generally used when the number of machines delivered > 5.



## Configurator



Configurator is a powerful tool to assist you in the selection of motors or geared motors combined with variable speed drives. Continuous evolution of this software reaches a new level with IMfinity® motors and geared motors, giving the user the possibility to link-up the motor and drive selection.

- Product selection help
- Printing technical specifications
- Printing of 2D and 3D CAM files
- Equivalent to 300 catalogues in 15 languages.

Best-in-class motors, geared motors and drives combined with this advanced tool ensure the best association is made when selecting products.

Register online at:  
<http://acim.nidec.com/motors/leroy-somer/products/configurator>

**Nidec Configurator** - All for dreams LEROY-SOMER

**Motors & Gears configurator** V8.232

Environment: Common  
 Ambiance: Non corrosive  
 Finish: -  
 Zone: Non specific  
 Method of cooling: Fan cooled motor  
 Protection type: -  
 Gearbox series: Cb  
 Application: General applications  
 Number of speed: Single-speed  
 Brake: -  
 Gearbox bearing and output shaft calculation: -  
 Number of network phases: 3

**Availability Informations**

Express Availability: Yes

**Nidec Configurator** - All for dreams LEROY-SOMER

**Gear type** V8.232

Exact output speed (min-1):  
 K factor:  
 Gearbox type: Cb3333  
 Index of reduction: 31.5  
 Input type: Integrated mounting

	K factor	Gearbox type	Exact output speed (min-1)	Exact ratio	Gearbox input flange	Available torque on the output shaft (N.m)
<input checked="" type="radio"/>	1.91	Cb3333	48.1	30.20	FF80M - H18x45	421.07
<input type="radio"/>	1.91	Cb3333	48.1	30.20	FF215 - 28x60	421.07

**Availability Informations**

Express Availability: Yes  
 Availability time: D+5  
 Maximum quantity: 5

**Nidec Configurator** - All for dreams LEROY-SOMER

**Motors & Gears configurator** V8.232

**Geared motor Compabloc**  
**Cb3333 30.2 S S B3 MI 4P LSES 100LR 2.2kW IFT/IE3 B14 230D/380Y/400Y/415Y-460Y 50-60Hz -**

€

Search, Home, and Navigation icons



## Service for drive systems

---

### Audit & Advice

- Facility audit
- Energy optimisation
- Modernisation
- Facility management



### Installation & commissioning

- Installation
- Commissioning
- Extended warranty
- Training



### Maintenance

- Emergency services
- Services upon request
- Contracts

## MAINTENANCE

The service life of your facilities ensures continuity of your production flow and extends the lifetime of the equipment, ensuring a good return on investment.

For emergency situations, we have defined the appropriate services to offer you the solution ensuring your installations will restart promptly.

Experts close to your facilities available 24/7 monitoring proper operation of your equipment, able to define the level of intervention required according to the context, and able to intervene urgently: that is our vision of maintenance.

## MONITORING CONTRACTS

Maintaining drive systems in operational condition at all times is vital for proper operation of your equipment, whether these are line production units or utilities.

Parameter monitoring programmes ensure drifts and anomalies likely to cause malfunctions are detected early.

## MAINTENANCE CONTRACTS

Observing inspection intervals and changing first wear devices and parts are often complex and tedious operations because of the multiplicity of equipment present in an industrial site.

To facilitate these operations, our solutions allow managing the maintenance of drives.

## EXPRESS AVAILABILITY COMMITMENT



- Ready to ship in 1 to 10 working days
- Motors, servo motors, geared motors, drives, options and accessories
- Limited quantity
- Access to the list of eligible products for *Express* availability, and the corresponding conditions, directly on our website [www.leroy-somer.com](http://www.leroy-somer.com)

Express Availability

Meeting urgent needs while meeting the lead times proposed to the clients requires effective logistics.

Availability of geared motors is ensured by complementarity between the network of approved partners and Leroy-Somer central service.

The colour code in the « Express Availability » selection grids ensures product lead times are indicated per family and quantities ordered.

Call Leroy-Somer.

The illustration below indicates the lead time for equipment selected in page 19, i.e. D+5; D being the day of reception of the order in the factory before 12:00 am.

Geared motors IMfinity® IE2 class  
Helical gears COMPABLOC, MANUBLOC, ORTHOBLOC  
Standard environment - Fixed speed

Integral mounting	MI
Universal mounting	MU
Input shaft mounting	AP

AVAILABILITY TIMES EX WORKS (FRANCE), IN WORKING DAYS

Orders received, within the maximum quantity limit, by the factory on day D before 12:00 pm Central European Time, will have the following Availability. For products with options, availability will be that of the longest lead-time item, i.e. the product or its options. If the order is received after 12:00 pm, 1 working day will be added to the stated lead time. The maximum quantity is per line of order. Above this maximum quantity, please consult your Sales Office.

D	D+1	D+2	D+5	D+10	Please consult
---	-----	-----	-----	------	----------------

IMfinity® IE2 class associated motors 4p (motors in italics excepted NC: Not Covered by IE Standards)

**IE2 class 230 V Δ / 380 V Y / 400 V Y / 415 V Y 50 Hz - 460 V Y 60 Hz**  
**380 V Δ / 400 V Δ / 415 V Δ / 690 V Y 50 Hz - 460 V Δ 60 Hz**

Type	IE	Mounting	Rated power P <sub>n</sub> kW	400 V	Cb 15-	Cb 30-	Cb 31- Ot 31- Mub 31-	Cb 32- Ot 32- Mub 32-	Cb 33- Ot 33- Mub 33-	Cb 34- Ot 34- Mub 34-	Cb 35- Mub 35-	Cb 36- Ot 36- Mub 36-*	Cb 37- Ot 37- Mub 37-*	Cb 38- Mub 38-*	Ot 39-
<i>LSES 80 LG</i>	IE2	MI or MU	0.75	Y		5	5	5	5	5	5				
<i>LSES 80 LG</i>	IE2	MI or MU	0.9	Y	5	5	5	5	5	5					
<i>LSES 90 SL</i>	IE2	MI or MU	1.1	Y		5	5	5	5	5					
<i>LSES 90 L</i>	IE2	MI or MU	1.5	Y		5	5	5	5	5					
<i>LSES 90 LU</i>	IE2	MI or MU	1.8	Y		5	5	5	5	5		2	2		
<i>LSES 100 L</i>	IE2	MI or MU	2.2	Y		5	5	5	5	5		2	2		
<i>LSES 100 LR</i>	IE2	MI or MU	3	Y		5	5	5	5	5		2	2		
<i>LSES 112 MG</i>	IE2	MI or MU	4	Y		5	5	5	5	5		2	2		
<i>LSES 132 SU</i>	IE2	MI or MU	5.5	Y		5	5	5	5	5		2	2		
<i>LSES 132 M</i>	IE2	MI or MU	7.5	Δ		5	5	5	5	5		2	2	2	
<i>LSES 132 M</i>	IE2	MI or MU	9	Δ		5	5	5	5	5		2	2	2	
<i>LSES 160 MR</i>	IE2	MI or MU	11	Δ		2	2	2	2	2		2	2	2	
<i>LSES 160 L</i>	IE2	MI or MU	15	Δ		2	2	2	2	2		2	2	2	
<i>LSES 180 MT</i>	IE2	MI or MU	18.5	Δ		1	1	1	1	1		1	1	1	
<i>LSES 180 LR</i>	IE2	MI or MU	22	Δ		1	1	1	1	1		1	1	1	
<i>LSES 200 LR</i>	IE2	MI or MU	30	Δ		1	1	1	1	1		1	1	1	
<i>LSES 225 ST</i>	IE2	MU	37	Δ								1	1	1	
<i>LSES 225 MR</i>	IE2	MU	45	Δ								1	1	1	
<i>LSES 250 ME<sup>†</sup></i>	IE2	MU	55	Δ								1	1	1	
<i>LSES 280 SD<sup>†</sup></i>	IE2	MU	75	Δ								1	1	1	
<i>LSES 280 MD<sup>†</sup></i>	IE2	MU	90	Δ								1	1	1	
<i>LSES 315 SP<sup>†</sup></i>	IE2	MU	110	Δ								1	1	1	

†. motor B35 obligatory NC: not concerned by IE Standards

COMPABLOC - MECHANICAL OPTIONS CORRESPONDING TO THE MOUNTING FORM

Type	Cb 1-stage MI forms					Mounting		Cb 1-stage		Equipment		
	Feet	BS	Flange mounted	BD1	BD2	BD3	BT	Universal	Input shaft	AP	PAO ISO VG150	Lubrication
Cb 3031	S							MU	AP			
Cb 3131												
Cb 3231												
Cb 3331												
Cb 3431												
Cb 3531												

Type	Cb multistage MI forms						Mounting		Cb multistage		Equipment					
	Feet	BS	Flange mounted	BD1	BD2	BD3	BR	BT	Backstop <sup>†</sup>	AD/AP-MI-MU	Universal	Input shaft	AP	PAO ISO VG150	Lubrication	Heat exchanger
Cb 1502-1503	S										MU	AP				
Cb 3032-3033																
Cb 3133																
Cb 3233																
Cb 3333																
Cb 3433																
Cb 3533																
Cb 3633																
Cb 3733																
Cb 3833																

†. Cb 36 to 38: AD (backstop) not allowed for V5, V1 operating positions.

HELP YOU SAVE TIME

The lead time charters for products in Express Availability are accessible directly in our web pages: <http://lrsm.co/dispoen> (chapter 4: Gearboxes - Geared motors)

You can also scan the QR code below for direct access:



**Express  
Availability**



## **Express Availability commitment**

**Drives, motors, geared motors and servomotors you need,  
when you need them**



**LEROY-SOMER™**

**LEROY-SOMER**<sup>™</sup>

[www.leroy-somer.com](http://www.leroy-somer.com)

**Connect with us at:**

[twitter.com/Leroy\\_Somer\\_en](https://twitter.com/Leroy_Somer_en)

[facebook.com/leroy-somer.nidec.en](https://facebook.com/leroy-somer.nidec.en)

[youtube.com/user/LeroySomerOfficiel](https://youtube.com/user/LeroySomerOfficiel)

[linkedin.com/company/leroy-somer](https://linkedin.com/company/leroy-somer)



**Nidec**  
All for dreams

© 2021 Moteurs Leroy-Somer SAS. The information contained in this brochure is for guidance only and does not form part of any contract. The accuracy cannot be guaranteed as Moteurs Leroy-Somer SAS have an ongoing process of development and reserve the right to change the specification of their products without notice.

Moteurs Leroy-Somer SAS. Headquarters: Bd Marcellin Leroy, CS 10015, 16915 Angoulême Cedex 9, France. Share Capital: 38 679 664 €, RCS Angoulême 338 567 258.



Distributor

**LEROY-SOMER**<sup>TM</sup>

<https://motorielettrici.elleuno.eu>

[info@elleuno.eu](mailto:info@elleuno.eu)

Phone +39 028131848

Fax +39 0289190444

ELLEUNO s.r.l.

Via Bari 24 20143 MILANO Italy