



POULIBLOC



Shaft mount speed reducer



LEROY-SOMER[™]

Nidec
All for dreams

Poulibloc 2000

Reducer with exclusive taper bushing feature

Available in 8 sizes up to 55 kW - 4 standard reduction ratios : 1/5 - 1/12 - 1/20 - 1/25

Unique taper bushing design for easy and versatile mounting on driven shaft.

A wide range of bushing bore sizes is available for each type of reducer.



Easily installed backs-top.



Magnetic plug as standard.

Torque arm bracket can be mounted in three positions.

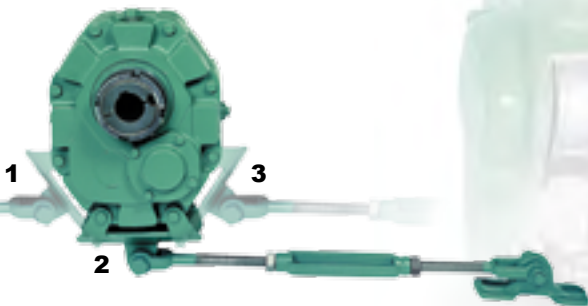

Torque arm with tensioner and bushing spanner wrench are supplied as standard.

Ribbed housing is precision machined in matched pairs for maximum strength, rigidity and permanent gear alignment.

Hollow shaft protected by removable cap.

Case carbonized gears to 60/64 Rockwell C.

Ground, crown shaved or skived helical gears.

Oversized taper roller and ball bearings.

Standard double lip seals on ground and polished shafts.



Selection

Poulibloc (Pb) gearbox : RK plain form, with TB taper bush (Pb 2005 to Pb 2720)

Class
I
(Kp=1)

Input shaft mounting **AP**

10 à 355 min⁻¹

LS, LSES motors, power kW

Output speed min ⁻¹	0,37	0,55	0,75	0,9	1,1	1,5	1,8	2,2	3	4	5,5	7,5	9	11	15	18,5	22	30	37	45	55'	
	4 pole																					
	71	80	90	100	112	132	160	180	200	225	250											
2 stages, reductions 12, 15, 20 and 25 ²																						
25									2225					2525		2625						
28		2025						2125			2325		2425									
31,5									2220					2420								
35,5			2020										2325		2520		2620					
40								2120														
45					2015								2315		2420	2515		2615		2720		
50									2115	2215					2412							
56										2212												
63													2312									
71												2215			2315							
80					2012												2512		2612		2712	
90													2215			2412						
100										2112					2312							
112													2212									
125																						
140														2212								
1 stage, reduction : 5 ²																						
112																						
125																						
140																						
160																						
180										2005				2105	2205		2405					
200																2305			2505			
225																				2605		
250																						
280																						
315																						

1. LSES B35 obligatory
2. i Poulibloc selected depending on the pulley Ø ratio of 1/1, 1/2 or 1/3

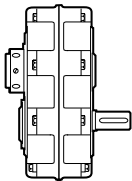

Selection

Required power :	4 kW
Required speed :	60 min ⁻¹
Duty factor necessary for the application :	Kp = 1
Diameter of driven shaft :	45
Mounting :	taper bush

Designation : Pb 2112 i : 11,5 RK W TB Ø 45H7 M AP (motor LSES 112M 4 kW - pulley ratio 1/2)
or Pb 2120 i : 20,6 RK W TB Ø 45H7 M AP (motor LSES 112M 4kW - pulley ratio 1/1,2)

Dimensions (mm)

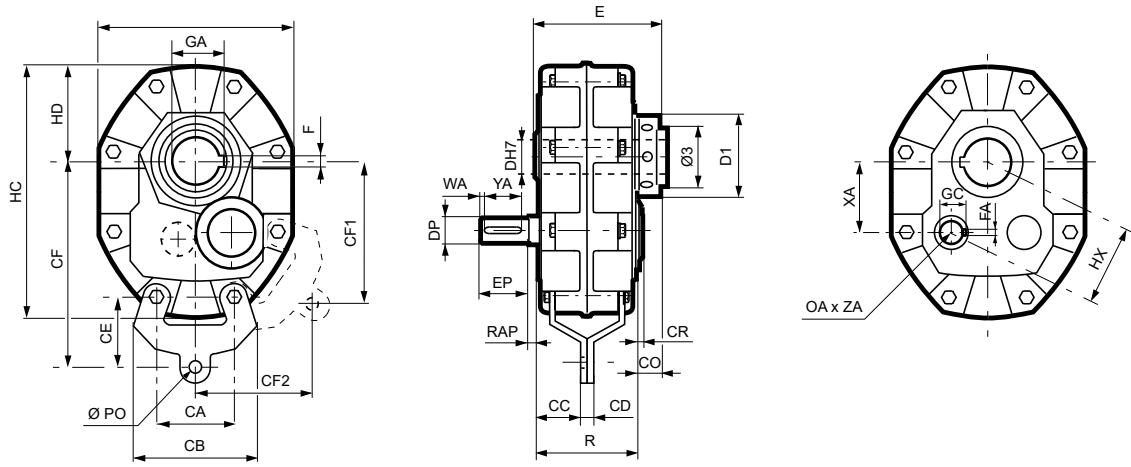

Typ	Reducers										Output shaft and taper bush							Input shaft							kg					
	CA	CB	CC	CD	CE	CF	CF1	CF2	CN	CO	CR	HC	HD	HX	PO	R	XA	Ø3	D1	E	DP	EP	FA	GC		OA	ZA	RAP	WA	YA
Pb 27--	-	416	121,3	38	-	521,5	-	-	550	80	13	890	405	273	32	231	253	M175x3	215	312,5	65	130	18	69	M20	40	0	-	0	295
Pb 2612 to 2625	179	277	122	20	130	440	307	247	410	58	23	522	191	192	17	238	172,2	M135x3	165	300,5	55	120	16	59	M16	36	0	5	105	158
Pb 2605	179	277	122	20	130	440	307	247	410	58	23	522	191	192	17	238	172,2	M135x3	165	300,5	48	120	14	51,5	M16	36	0	5	105	158
Pb 2512 to 2525	156	234	109	16	110	377	264	212	357	44	13	452	165	164	17	210	147,7	M108x3	135	259	50	110	14	53,5	M16	36	0	5	100	106
Pb 2505	156	234	109	16	110	377	264	212	357	44	13	452	165	164	17	210	147,7	M108x3	135	259	38	80	10	41	M12	26	0	5	100	106
Pb 24--	136	213	75	10	100	332	233	191	316	36	13	395	146	145	16	170	131,8	M97x3	121	207	50	110	14	53,5	M16	36	0	5	100	68
Pb 23--	123	190	67	10	80	290	204	156	284	36	13	361	133	126	16	147	112	M80x2	106	184	35	80	10	38	M12	26	0	3	72	52
Pb 22--	108	172	61	10	75	260	177	139	252	36	13	320	118	107	16	131	95,8	M68x2	96	171	32	80	10	35	M10	22	0	4	72	32
Pb 21--	90,5	162	55	10	72	227	157	130	214	36	13	269	100	92	16	120	84,3	M64x2	86	158	28	60	8	31	M10	22	0	6	48	24
Pb 20	82,5	140	48	10	68	210	140	112	198	36	13	245	90	85	16	109	76,6	M52x2	75	138	24	60	8	27,5	M8	19	0	6	48	19

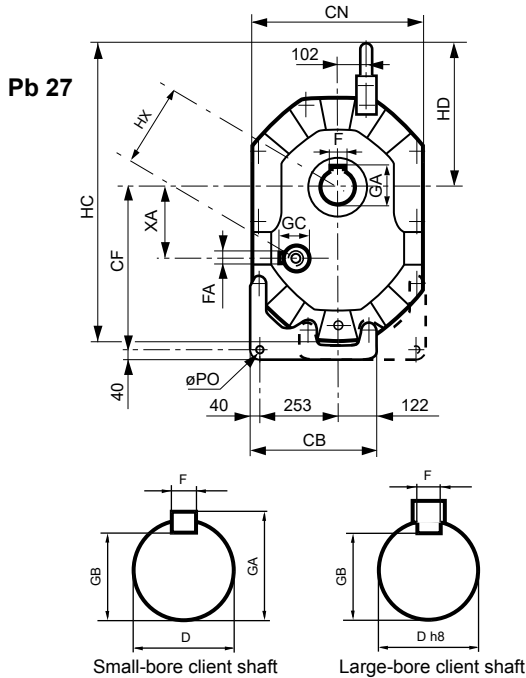

D ^{H7}	Standard bores			Taper bush TB for Pb							
	F	GB	GA	20	21	22	23	24	25	26	27
20	6	16,5	22,5	◇							
25	8	21	28	◇	◇						
30	8	26	33	◇	◇	◇					
35	10	30	38	◇◇	◇	◇	◇				
40	12	35	43	◇◇	◇	◇	◇				
45	14	39,5	48,5		◇◇	◇	◇	◇			
50	14	44,5	53,5		◇◇	◇◇	◇	◇			
55	16	49	59			◇◇	◇◇	◇			
60	18	53	64				◇◇	◇	◇		
65	18	58	69					◇	◇		
70	20	62,5	74,5					◇◇	◇	◇	
75	20	67,5	79,5					◇◇	◇	◇	
80	22	71	85						◇◇	◇	
85	22	76	90						◇◇	◇	
90	25	81	95							◇◇	◇
95	25	86	100								◇◇
100	28	90	106								◇◇
110	28	100	116								◇
120	32	109	127								◇
Minimum length of client shaft				80	82	105	116	134	153	194	260

◇ : Client key with small bores, dimensions GA shown
 ◇◇ : Key supplied, dimensions GA not shown
 For tapered bush adaptation, please consult maintenance manual.

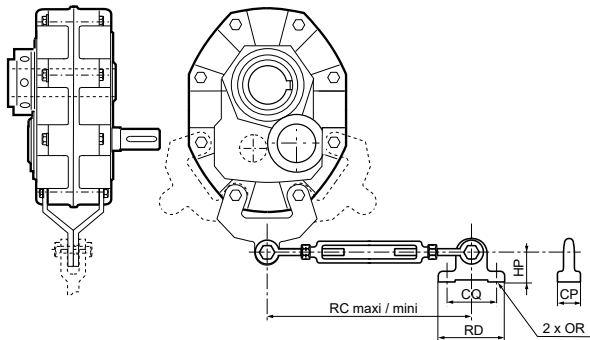

Typ	Torque arm						
	CP	CQ	HP	OR	RC maxi	RC mini	RD
Pb 27--	80	210	80	32	840	670	280
Pb 26--	50	105	45	17	540	440	144
Pb 25--	50	105	45	17	540	440	144
Pb 24--	53	95	38	15	450	365	150
Pb 23--	53	95	38	15	450	365	150
Pb 22--	53	95	38	15	450	365	150
Pb 21--	53	95	38	15	450	365	150
Pb 20--	53	95	38	15	450	365	150

The torque arm should be positioned in line with the mounting bracket.
 3 positions are possible (Pb27 : 2 positions).

Poulibloc 2000

Reducer with exclusive taper bushing feature

Examples of applications



.....> Screw conveyor drive



.....> Belt conveyor drive

**Other product
available in POULIBLOC range**

POULIBLOC 3000

Single reduction gearbox.

Reduction ratio 1/5 and 1/8.

Cylindrical bore.

Economical series.

Available in 3 sizes up to 11 kW,
with oil or grease lubrication.





LEROY-SOMER[™]

www.leroy-somer.com

Connect with us at:

twitter.com/Leroy_Somer

facebook.com/leroy-somer.nidec

youtube.com/user/LeroySomerOfficiel

theautomationengineer.com (blog)



Nidec
All for dreams

© 2017 Moteurs Leroy-Somer SAS. The information contained in this brochure is for guidance only and does not form part of any contract. The accuracy cannot be guaranteed as Moteurs Leroy-Somer SAS have an ongoing process of development and reserve the right to change the specification of their products without notice.

Moteurs Leroy-Somer SAS. Headquarters: Bd Marcellin Leroy, CS 10015, 16915 Angoulême Cedex 9, France. Share Capital: 65 800 512 €, RCS Angoulême 338 567 258.



Distributor

LEROY-SOMERTM

<https://motorielettrici.elleuno.eu>

info@elleuno.eu

Phone +39 028131848

Fax +39 0289190444

ELLEUNO s.r.l.

Via Bari 24 20143 MILANO Italy